

Determination 2024/027

Compliance of head flashing stop ends extending past the cladding line as an alternative solution to E2.

51 Puketiro Drive, Kumara Junction, Hokitika, Westland

Summary

The determination will consider whether the constructed head flashings to weatherboard claddings where the stop ends extend past the cladding line comply with E2.3.2 to prevent the penetration of water that could cause undue dampness and damage by way of an alternative solution.



Cover Image: Head flashing to horizontal weatherboard cladding with the stop end projecting past the cladding.

The legislation discussed in this determination is contained in Appendix A. In this determination, unless otherwise stated, references to “sections” are to sections of the Building Act 2004 (“the Act”) and references to “clauses” are to clauses in Schedule 1 (“the Building Code”) of the Building Regulations 1992.

1. The matter to be determined

- 1.1. This is a determination made under due authorisation by me, Andrew Eames, Manager Advisory Ministry of Business, Innovation and Employment (“the Ministry”), for and on behalf of the Chief Executive of the Ministry.¹
- 1.2. The parties to the determination are:
 - 1.2.1. M Colville, the licensed building practitioner who carried out the building work and applied for this determination (“the builder”)
 - 1.2.2. Westland District Council, carrying out its duties as a territorial authority or building consent authority (“the authority”)
 - 1.2.3. V Sharp, the owner of the house (“the owner”).
- 1.3. This determination arises from the builder’s view that the construction of head flashings with the stop ends extending past the cladding on a new dwelling comply with Building Code clause E2 *External Moisture* by way of an alternative solution. After inspections by the authority and correspondence, the authority subsequently refused an amendment to the building consent and issued a notice to fix for the head flashings.
- 1.4. The matter to be determined, under section 177(1)(a), is whether the constructed head flashings on the new dwelling comply with E2.3.2 *External Moisture* by way of an alternative solution.
- 1.5. In deciding this matter, I must consider the construction of the end of the head flashings with the stop-ends projecting through the claddings and whether, as an alternative solution, this complies with clause E2.3.2.

Matters outside this determination

- 1.6. In determining the matter, I have not considered:
 - 1.6.1. The decision and reasons for refusal of the amendment for the building work described in the matter.

¹ The Building Act 2004, section 185(1)(a) provides the Chief Executive of the Ministry with the power to make determinations.

- 1.6.2. The decision to issue a notice to fix for the building work described in the matter.
- 1.6.3. Any decisions made by the authority in relation to the code compliance certificate.

2. The building work

- 2.1. The issued building consent BC230088 was for the construction of a new single level detached dwelling on the owner's property. The plans show the dwelling having aluminium window and door joinery and 3 wall cladding types all on a cavity; horizontal cedar weatherboards, vertical fibre cement weatherboards and brick masonry. The building is identified in the drawings as in a High Wind zone².
- 2.2. During construction, the head flashings, in the areas of weatherboard claddings, were installed above the building openings with a turn up at either end acting as in-built stop ends, with these stop ends extended through the claddings to the front edge of the flashing. The junction between the stop end and the vertical upstand of the flashing behind the cladding has been sealed (figure 1).

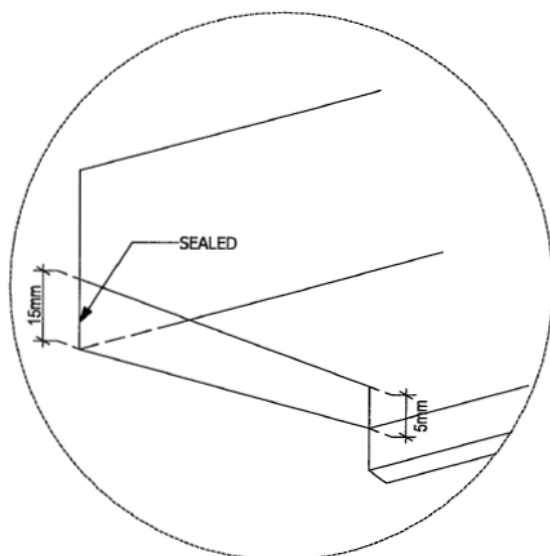

Figure 1: Detail of the head flashing stop end as constructed (not to scale)

- 2.3. This differed from the consented plans where the head flashings were to have a cavity batten installed against either end or alternatively being "formed with stop ends as per [Acceptable Solution] E2/AS1".
- 2.4. The parties have not raised any disputes in relation to other areas of the head flashings such as the flashing upstand, overhang to the window and door units, or installation of the cavity closers.

² As described in NZS 3604 Timber Framed Buildings.

3. Background

- 3.1. On 30 June 2023, the authority issued building consent BC230088 for the construction of the new detached dwelling on the owner's property.
- 3.2. Construction of the dwelling commenced in July 2023 and the authority undertook a 'Post Wrap/Cavity' inspection on 13 September 2023. This included the head flashings to the areas to be clad with weatherboards, which it passed. However, the authority did note on the inspection record that the head flashings and stop ends were not to extend to the outside of the cladding.
- 3.3. On 2 October 2023, the authority returned to the site to carry out an additional 'Post Wrap/Cavity' inspection, in conjunction with a 'Half High Brick' inspection. By this time, the weatherboard claddings had been installed. The authority failed the 'Post Wrap/Cavity' inspection, giving the reasons that the head flashings, having the stop ends extend past the weatherboard claddings, did not meet the consented plans that indicated they were to comply with the acceptable solution E2/AS1³ and the site instructions from the previous inspection had not been followed.
- 3.4. For the next month, correspondence between the builder and authority continued to seek resolution on the issue of the head flashings and on 25 October 2023, the builder applied for a minor variation for the change from the consented detail. The authority indicated the following day that an amendment to the building consent would be required.
- 3.5. An amendment application was lodged with the authority on 10 November 2023. The application was supported by the comparison of the constructed detail with other E2/AS1 details, other certified claddings that use the detail and correspondence from one of the cladding manufacturers confirming the detail was acceptable with its cladding product.
- 3.6. Following a request for further information from the authority and a response, the authority refused the amendment on 27 November 2023, giving the reason "the proposed alternative solution to the installation of head flashings does not meet current design philosophy of E1/AS1, E1/AS1 details or the Codemark product [of the claddings] for their installation in cavity supported wall claddings".
- 3.7. A notice to fix was subsequently issued on 13 February 2024 and a determination application was accepted on 7 May 2024.

³ Acceptable Solution E2/AS1 (third edition, amendment 10, effective 05/10/2020)

4. Submissions

The Builder

- 4.1. The builder submitted that they believe the constructed head flashings comply with E2.3.2 by way of an alternative solution because:
 - 4.1.1. How the head flashings have been constructed exceeds the minimum requirements set by E2/AS1, “ensuring that any water blown into the gap created above the head flashing and between the cladding is directed to the front of the cladding”, and that this aligns with the 4 D’s principles of water management in buildings.⁴
 - 4.1.2. The stop ends finish on the outside of the building envelope at the front of the head flashing. This differs from E2/AS1 which requires the stop end to terminate at the back of the cladding.
- 4.2. To support their alternative solution, the builder has provided:
 - 4.2.1. A comparison to E2/AS1 figure 85, for a bevel back weatherboard on a cavity construction, where the stop end terminates behind the cladding.
 - 4.2.2. A detail for a metal weatherboard cladding from a different manufacturer which has the stop end finishing on the outside of the cladding and has a BRANZ appraisal for the cladding product. The builder has indicated that this has previously been accepted by the authority in other consents.
 - 4.2.3. Correspondence from one of the cladding manufacturer stating that the detail “is acceptable with [the manufacturers] claddings” and that the “standard product warranty applies when the cladding is installed in conjunction with such a flashing”.
- 4.3. The builder also submitted that they believe the change in the detail from the consented plans should be considered as a minor variation to the building consent.

The Authority

- 4.4. The authority submitted, in summary, that it believes the constructed head flashings do not comply with E2.3.2 by way of an alternative solution because:
 - 4.4.1. E2.3.2 requires roofs and walls to prevent the penetration of water that could cause undue dampness and/or damage to the building and in reading the commentary in E2/AS1, it states that there are additional issues in relation to weatherproofing when the stop ends penetrate the cladding.

⁴ As discussed in paragraph 5.7

- 4.4.2. No relevant expert advice or evidence, including specific cases of in-service history, has been provided to demonstrate that, as constructed, the head flashings would perform as required by E2.3.2.
- 4.5. It also submitted that if the stop ends were to fail, there would be a significant increase in the likelihood of water entering the building in contradiction with E2.3.2.
- 4.6. In addition, the authority also indicated that it believes these types of changes to head flashings should be addressed through an amendment process, “due to the risk of failure of the product” and to it being a change to the exterior cladding. The decision to require an amendment, rather than a minor variation, has been corroborated by external advice received by the authority.

The Owner

- 4.7. The owner did not make a submission.

5. Discussion

Establishing Building Code Compliance

- 5.1. Section 17 requires all building work to comply with the Building Code and the code sets out the performance criteria for the assessment of building work. The performance criteria are the qualitative and quantitative requirements that are to be satisfied in performing the functional requirements of a Building Code clause. If the performance criteria are not satisfied, the building work will be non-compliant with that Building Code clause.
- 5.2. In this case, I will consider whether the termination of the head flashing stop ends on the outside of the cladding comply with performance criteria E2.3.2 by way of an alternative solution.
- 5.3. Section 19 of the Act sets out how compliance with the Building Code is established. It gives various methods that can be used for establishing compliance, such as acceptable solutions, verification methods and current registered product certificates. These means of compliance must be accepted by the building consent authority if they are being used as the compliance pathway.
- 5.4. However, these are not the only ways building work can comply with the Building Code. There can be situations where the acceptable solutions and other “deemed to comply” documents in section 19 do not provide a suitable construction detail or method. In these circumstances, an “alternative solution” for compliance with the Building Code is required.
- 5.5. For an alternative solution, evidence to demonstrate how the proposed building work will comply with the Building Code should be provided to the authority. The

level of evidence will vary depending on the complexity of the building work and may include in-service history, expert judgement, comparison to compliance documents and use of other documents, such as determinations, standards, and technical trade literature.

Compliance with E2.3.2

- 5.6. The performance criteria of E2.3.2 states “Roofs and exterior walls must prevent the penetration of water that could cause undue dampness, damage to building elements, or both”.
- 5.7. Wall cladding construction over a cavity incorporates four basic principles of water management in buildings, known as the “4 D’s”:
 - 5.7.1. Deflection: keeping water away from potential entry points.
 - 5.7.2. Drainage: providing means of removing water that does enter.
 - 5.7.3. Drying: allowing any remaining moisture to be removed by ventilation or diffusion.
 - 5.7.4. Durability: providing materials with appropriate durability.
- 5.8. In this case, I will consider the principles of deflection, drainage and drying.
- 5.9. The purpose of a head flashing over a building opening is to deflect water away from the junction between the joinery and building structure, and to also allow any water that may get into the cavity to drain to the exterior of the building. The cavity closers in the same area as the head flashings behind the claddings and at the bottom of the claddings allow for air flow through the cavity to remove moisture by evaporation or diffusion, drying it out.
- 5.10. Stop ends on head flashings are to limit any draining or windblown water from running down and across the flashing and entering the cavity at the sides of the building opening. If water reaches the horizontal end of the flashing, the stop end will direct it down to the outside of the building envelope.
- 5.11. In this case, the stop ends have been constructed to extend to the outer edge of the flashing, passing the cladding line. This differs from the requirements of E2/AS1 paragraph 9.1.10.4 d) i) where the stop end is to finish at the back side of the cladding.
- 5.12. For the part of the stop ends on the head flashings that are within the cavity, behind the cladding, I consider this to perform in a similar way as the requirements of E2/AS1, with the sealant between the stop ends and upstand of the flashings providing additional protection. Any water reaching the horizontal end of the flashing will not be able to enter the cavity at the side of the building opening.

- 5.13. When the stop ends reach the cladding line, photos show that these have been constructed to fit within the horizontal gap which allows to the front edge of the flashing to overhang the joinery unit. This gap does not appear to have been increased to allow the stop ends to extend past the cladding line and I do not consider this will allow the penetration of water that would cause undue dampness or damage.
- 5.14. I have been provided with photos of the constructed head flashings, specifically the horizontal junction between the stop ends and the claddings at the outer edge of the opening (see cover image). These photos show a small open gap between the stop ends and claddings that could allow windblown water to enter the cavity behind. While this increases the likelihood of water entering the cavity, I do not consider that this small amount of water will cause undue dampness or damage, taking into account the building design and wind zone. The water that may enter this small gap will be remedied through the drying and drainage principles of water management that the cavity system provides.
- 5.15. I consider that any water reaching the edge of the head flashing will be deflected by the stop ends and drain off the head flashing external to the building envelope, and therefore that the constructed stop ends to the head flashings will prevent the penetration of water that could cause undue dampness, damage to building elements, or both.

Additional Commentary

- 5.16. While excluded from the matter being determined, the parties have submitted differing views on whether this change in the head flashings discussed above requires a minor variation or amendment to the building consent. I consider that the change made to the head flashing stop ends does not affect compliance with the Building Code and therefore, could be addressed as a minor variation.

6. Decision

- 6.1. In accordance with section 188 of the Building Act 2004, I determine that the constructed head flashings, with the stop ends projecting through the claddings, comply with E2.3.2 by way of an alternative solution.

Signed for and on behalf of the Chief Executive of the Ministry of Business, Innovation and Employment on 31 May 2024.

Andrew Eames

Manager Advisory

APPENDIX A Legislation

17 All building work must comply with building code

All building work must comply with the building code to the extent required by this Act, whether or not a building consent is required in respect of that building work.

19 How compliance with building code is established

(1) A building consent authority must accept any or all of the following as establishing compliance with the building code:

(a) compliance with regulations referred to in section 20:

(b) compliance with an acceptable solution:

(ba) compliance with a verification method:

(c) a determination to that effect made by the chief executive under subpart 1 of Part 3:

(ca) a current national multiple-use approval issued under section 30F, if every relevant condition in that national multiple-use approval is met:

(d) a current registered product certificate, if every relevant condition in that product certificate is met:

(da) in relation to the design and manufacture of a modular component that is designed and manufactured by a registered MCM, a current manufacturer's certificate issued by that registered MCM:

(e) to the extent that compliance with a requirement imposed by regulations made under the Electricity Act 1992 or the Gas Act 1992 is compliance with any particular provisions of the building code, a certificate issued under any of those regulations to the effect that any energy work complies with those requirements.

(2) In considering whether something complies with the building code, a building consent authority or, as the case may be, a regional authority—

(a) must have regard to any relevant warning or ban in force under section 26(2); and

(b) may have regard to any guidance information published by the chief executive under section 175.