



## Determination 2012/065

### Regarding the refusal to grant an amendment to a building consent for a house with timber window and door joinery at 13 Grey Crescent, Torbay, Auckland



#### 1. The matters to be determined

1.1 This is a determination under Part 3 Subpart 1 of the Building Act 2004<sup>1</sup> (“the Act”) made under due authorisation by me, John Gardiner, Manager Determinations, Ministry of Business, Innovation and Employment (“the Ministry”), for and on behalf of the Chief Executive of the Ministry.

1.2 The parties to the determination are:

- the building owner, E Belinskaya (“the applicant”) acting through a building consultant (“the consultant”)
- Auckland Council (“the authority”), carrying out its duties as a territorial authority or building consent authority.

1.3 This determination arises from a decision by the authority to refuse to grant an amendment to a building consent for a partially constructed house, because it is not satisfied that the proposed changes to the window and door joinery will comply with

---

<sup>1</sup> The Building Act, Building Code, compliance documents, past determinations and guidance documents issued by the Ministry are all available at [www.dbh.govt.nz](http://www.dbh.govt.nz) or by contacting the Ministry on 0800 242 243.

certain clauses<sup>2</sup> of the Building Code (Schedule 1, Building Regulations 1992). Concerns about compliance are about the durability of the proposed joinery.

- 1.4 The matter to be determined<sup>3</sup> is therefore whether the authority was correct to refuse to issue an amended building consent for the house. In deciding this, I must consider whether the proposed window and door joinery to the house (“the joinery”) complies with Building Code Clause B2 Durability insofar as it relates to Clause E2 External Moisture. The joinery includes the windows and doors, the junctions with adjacent walls and the flashings, as well as the way the components are intended to be installed and work together.

## 1.5 Matters outside this determination

- 1.5.1 It appears that most matters raised by the authority about the joinery have been or are in the process of being resolved between the parties, and the authority’s remaining concern is limited to the durability of the joinery taking into account the species of timber used in its manufacture. I have also received no evidence relating to a dispute about any other matters related to this building.

- 1.5.2 Further amendments are proposed pending completion of revised drawings, including changing the stone veneer on basement walls to cedar weatherboards. This determination does not consider those changes and is limited to the durability of the proposed exterior joinery as outlined in paragraph 1.4.

- 1.6 In making my decision, I have considered:

- the consultant’s submission on behalf of the applicant, which includes:
  - technical information from the joinery manufacturer
  - the timber technologist’s report on the likely durability of the joinery timber and factory-applied preservative
- the report of the expert commissioned by the Ministry to advise on this dispute (“the expert”)
- the other evidence in this matter.

## 2. The building work

- 2.1 The building work consists of a large detached house situated on an exposed coastal site in a very high wind zone for the purposes of NZS 3604<sup>4</sup>. The house is three storeys high to the north and two storeys to the south; and is fairly simple in plan and form, with a medium to high weathertightness risk.

- 2.2 Construction is specifically engineered, with concrete walls, floors and foundations. The timber-framed roof includes multiple gables, with timber framing to gable end walls. Cantilevered concrete decks extend to the north and south from the upper floor and to the north from mid-level living areas.

---

<sup>2</sup> In this determination, unless otherwise stated, references to sections are to sections of the Act and clauses are to Building Code clauses.

<sup>3</sup> Under sections 177(1)(b) and 177(2)(a) of the Act

<sup>4</sup> New Zealand Standard NZS 3604:2011 Timber-framed Buildings

## 2.3 The wall construction

- 2.3.1 On exterior walls timber 'structural' battens are bolted to the concrete, with horizontal cedar weatherboards fixed through 20mm battens and building wrap to the underlying 45mm battens. The 20mm battens form a drained cavity between the weatherboards and the building wrap.
- 2.3.2 At the time of the expert's inspection, the house structure and roof were substantially complete, with the installation of structural battens underway. A sample window had been installed and several other windows had been put in place temporarily, pending resolution of the consent amendment.

## 2.4 Timber windows and doors

- 2.4.1 The original consent drawings called for aluminium joinery and the proposal is to substitute imported timber windows and doors; to be fitted within concrete wall openings as shown in the simplified sketch in Figure 1.

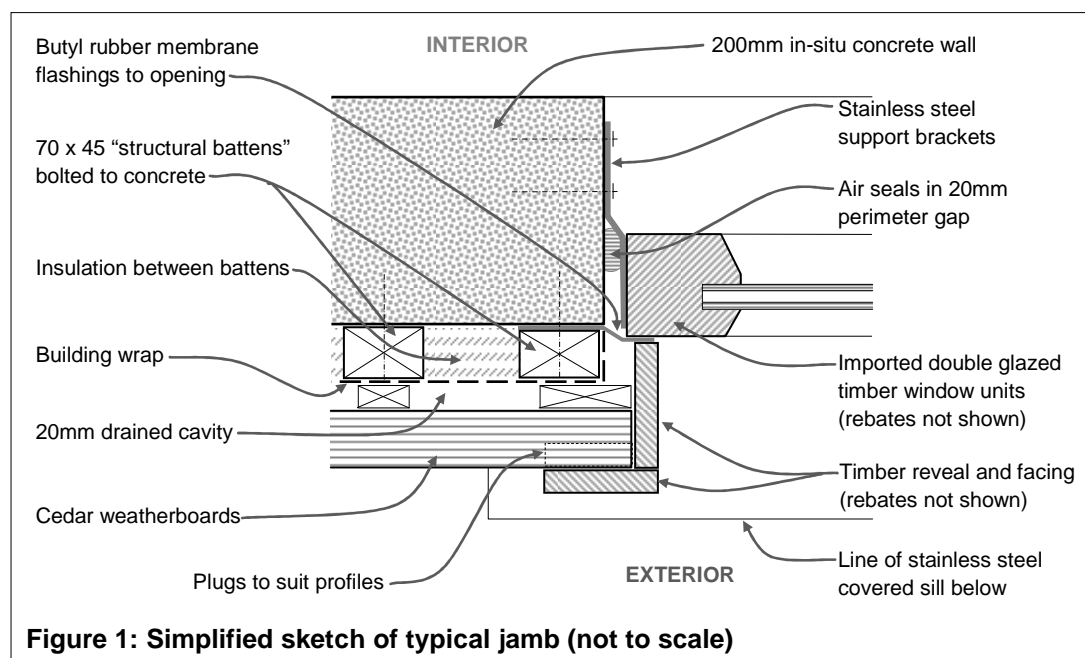

- 2.4.2 As shown in Figure 1, joinery units are supported by stainless steel brackets, with airseals fitted into a continuous 20mm perimeter gap and butyl rubber membrane covering the outer face of the gap. Building wrap is installed over battens and insulation, with weatherboards fixed over a drained cavity to the structural battens.
- 2.4.3 A projecting timber 'drip-head profile' is fixed to structural battens at window heads; with stainless steel head flashings above. Stainless steel also wraps over timber window sills, with rebated timber facings, scribes and reveals at jambs and head.

## 2.5 The proposed joinery

- 2.5.1 The proprietary double-glazed units are manufactured in Lithuania. The joinery manufacturer states that the joinery system was first tested and certified by the 'Interregional Window Institute' more than ten years ago for use in Russia. As no

local test records are available, a sample window has been installed to allow on-site weathertightness tests.

- 2.5.2 The joinery is manufactured from finger-jointed ‘Nordic Pine’ (*Pinus sylvestris*), which the expert describes as ‘less durable than the species included in B2/AS1 for external joinery, but more durable than untreated radiata pine’. The manufacturer states that the joinery was treated with a proprietary preservative (“the preservative”) followed by a 3-coat paint system.
- 2.5.3 The published literature (as obtained by the expert) indicates the treated joinery would comply with a relevant European standard (EN 599-1) if used in combination with its primers and topcoats. Following installation, an additional three-coat paint system will be site-applied.
- 2.5.4 The timber technologist’s report to the consultant dated 9 August 2012 includes the following points on the durability of the timber joinery (in summary):
- The situation in Europe is more complex than the single New Zealand standard NZS 3640:2003<sup>5</sup>, so establishing compliance can only be done in the broadest terms.
  - There is no documentation to show that the product does comply with the most relevant parts of EN 599<sup>6</sup>, which depend on L-jointed tests. As these can take 5 to 10 years, some UK manufacturers resist carrying out such testing.
  - Other European standards may also be relevant, such as BS 644<sup>7</sup> for factory-finished windows, which allows for dip treatment provided the treatment has been L-jointed tested.
  - The preservative in the joinery contains active ingredients with proven efficacy that are commonly used internationally, but durability depends on penetration into the wood, particularly into the untreated sapwood.
  - Without an L-jointed field test, diffusion of active ingredients into untreated inner zones is unknown as penetration might not exceed 2 to 5mm. However, NZS 3640 refers to NZS 3604, which requires full sapwood penetration by the preservative in order to conform to H3 level treatment.
  - Preservative treatment may not be the dominant factor in determining longevity, as performance will also depend on the building type and quality of maintenance. The minimum required durability of 15 years can be achievable for well-maintained window joinery that does not meet local standards.

### 3. Background

- 3.1 The building consent for the house (BP 1240986) was issued in 2011 based on drawings that specified aluminium window and door joinery. I have not seen a copy of the original consent documentation.

---

<sup>5</sup> New Zealand Standard NZS3640:2003 Chemical preservation of round and sawn timber.

<sup>6</sup> British Standard BS EN 599-1:2009 Durability of wood and wood-based products. Efficacy of preventive wood preservatives as determined by biological tests.

<sup>7</sup> British Standard BS 644:2009 Timber windows. Fully finished factory-assembled windows of various types.

## 3.2 The amendment application

3.2.1 The applicants apparently decided to change the aluminium joinery to timber; revised drawings and specifications were prepared in May 2012 and the consultant applied to the authority on the applicant's behalf for an amendment to the building consent in June 2012.

3.2.2 The authority acknowledged the application on 14 June 2012, noting that untreated pine joinery had not previously been approved by the authority and requesting further information. In particular, the authority was concerned about insufficient information relating to (in summary):

- the proposed timber joinery compared to similar local products
- a comparable history of use of the joinery
- in-service testing of the joinery
- relevant product certification for local conditions
- expert opinion as to the timber treatment.

3.2.3 The consultant responded on the same day, including the following (in summary):

- the profiles are similar to those shown in NZS 3610<sup>8</sup>
- similar timber joinery has been used in Europe for many decades
- a representative sample window will be installed and tested to the authority's approval prior to full installation of cladding and joinery
- as local product certification is not available, all relevant information has been submitted with the application
- there is no information about the treatment, if any, of the timber.

3.3 The consultant also sought advice from the Ministry on the authority's concerns about durability of the timber joinery. In response, the Ministry noted (in summary):

- As part of the external envelope, the joinery requires a minimum durability of 15 years, 'with only normal maintenance'.
- In regards to maintenance and inspection regimes, past determinations have considered straw bale construction, where limiting moisture ingress was critical. A documented and clearly detailed maintenance and inspection regime included within the consent documentation gives the owner the responsibility for ensuring the specified regime is followed.
- All timber joinery requires regular maintenance but, given the unknown level of treatment of the timber, it may be useful to state that and detail the paint system and repairs of any defects as part of ongoing maintenance.
- In this house, the joinery is installed within a concrete structure, so the consequences of any failure are less than in a timber-framed building. Also, most joinery is readily accessible for inspection and maintenance.

---

<sup>8</sup> New Zealand Standard NZS 3610: 1979 Specification for profiles of mouldings and joinery

- 3.4 The consultant sought further information from the manufacturer, who confirmed that the coating system included a preservative (see paragraph 2.5.3). The consultant then sought advice about the durability of the joinery from a timber technologist, who provided a report dated 9 August 2012 as outlined in paragraph 2.5.4.
- 3.5 The Ministry received an application for a determination from the consultant on 24 August 2012.

## **4. The submissions**

### **4.1 The applicants' submission**

- 4.1.1 In a submission on the applicant's behalf, the consultant set out the background to the dispute, described the timber joinery and its proposed installation, outlined information received from the manufacturer and the timber technologist, and included the following comments on expected durability (in summary):
- Clause B2.3.1 requires 15 year durability for doors and windows given 'normal maintenance'. The detailed and precise maintenance schedule prepared for proposed the timber joinery is far in excess of 'normal maintenance' and 'probably of a greater frequency than is absolutely necessary.'
  - There are no known examples of timber joinery that has failed where a detailed regular maintenance schedule was strictly adhered to.
  - There are 'broadly similar' instances of alternative solutions requiring a high degree of maintenance which are granted building consent.
  - The authority routinely inspects joinery during recladding work prior to re-fitting and accepts producer statements from the contractor, joinery consultant and/or manufacturer.
  - It is 'virtually impossible' for any significant joinery defects and moisture ingress/damage to develop between proposed six-monthly inspection periods; and in the unlikely event of undetected moisture ingress, damage would not be significant due to the concrete construction.
- 4.2 The consultant provided copies of:
- the amended drawings and specifications for the proposed joinery
  - the joinery manufacturer's technical information and statements
  - the timber technologist's report dated 9 August 2012
  - correspondence with the manufacturer, the authority, and the Ministry
  - the proposed maintenance schedule for the timber joinery
  - construction photographs of installation of the sample window
  - various other statements and information.
- 4.3 A copy of the submission and other evidence was provided to the authority, which made no submission in response.

- 4.4 A draft determination was issued to the parties on 8 October 2012.
- 4.5 The applicant accepted the draft subject to comment that the sample invasive testing suggested by the expert was considered unnecessary unless non-invasive readings were found to be high, and that the maintenance schedule would be amended to include twice yearly inspections by a building consultant. The applicant submitted that the authority was in agreement with that proposal and also noted that moisture content readings of timber sill packers would not be necessary because they will be plastic instead of timber.
- 4.6 The authority accepted the draft without comment in a response received on 18 October 2012.

## 5. The expert's report

- 5.1 As mentioned in paragraph 1.6, I engaged an independent expert to assist me. The expert is a member of the New Zealand Institute of Architects and inspected the partially completed house and timber joinery on 9 September 2012; providing a report dated 19 September 2012.

### 5.2 General

- 5.2.1 The expert noted that construction is being carried out by 'a reputable Auckland based contractor who specialises in light commercial and high end residential construction' and described the overall standard of workmanship completed to date as 'workmanlike'.

### 5.3 The timber joinery

- 5.3.1 The expert inspected the joinery stored on site, noting that:
- joinery appeared to be manufactured to a 'good factory standard, with close fitting joints, smooth finish and generally uniform smooth paint finish', although paint coating to some end grain joints is insufficient and will need the additional proposed onsite coating
  - a sash damaged during freight (and to be replaced) had not resulted in damaged joints or glass, demonstrating the robustness of the joinery
  - sill blocking to some doors is of an unknown wood species and treatment
  - the entrance door frame was made with a light pink coloured wood that the consultant reported to be Meranti<sup>9</sup>.
- 5.3.2 The expert also inspected the sample window installation, noting that:
- the window is supported within the concrete wall by stainless steel brackets twice bolted into the concrete and a foam air seal is applied to the gap
  - membrane 'flashings' to the outer concrete face are invisible (I note that these are visible in construction photos of the sample window)

---

<sup>9</sup> Meranti: the trade name commonly used to describe a light hardwood of *Shorea* genus

- the most recent revision (Sheet D13B dated 11 September 2012) shows:
  - solid timber sills fully covered with stainless steel flashings extending down the top and face of the sill
  - stainless steel head flashings installed over underlying butyl rubber flashings
- the sample window did not include the stainless steel head flashing and the sill flashing did not extend the full length of the timber sill.

## 5.4 Drawing review

5.4.1 The expert reviewed the most recently revised drawings and noted that, as drawn:

- head flashings provide a capillary path under the flashing
- the anti-capillary gap between the cladding and head flashing is only 3mm and likely to become blocked
- some notes are missing from the drawings, such as joinery profiles, timber species and treatment for trim, packers etc
- cross-references to locations of window details are missing from sill codes on the lower floor plan
- various other minor omissions (as noted on the drawings in the expert's report).

## 5.5 Amendment application review

5.5.1 The expert reviewed the documents submitted to support the use of the timber joinery as an alternative solution, and I have taken those comments into account in paragraph 6. Comments included (in summary):

- According to TRADA<sup>10</sup>, the wood species *Pinus sylvestris* is classified as 'slightly durable', with fast growth UK plantation wood ('Scots pine') generally less durable than northern Europe-grown product ('Nordic pine').
- The above timber is more durable than *Pinus radiata* (classified as 'not durable') but less durable than *Western red cedar* (classified as 'durable').
- The factory-applied preservative is not equivalent to H3 treatment as penetration may be limited and there is no evidence of satisfactory testing.
- The factory-applied paint thickness is very thin on some end grain wood and further site-applied painting is proposed to exposed parts of the joinery.
- The evidence of history of use is based only on general statements provided by the manufacturer; with no length of service, environment of use, or installation technique described in order to allow comparison with the subject situation.
- A certified Swedish brand of timber joinery is broadly comparable in profile and design to the subject timber joinery, but is manufactured from redwood treated with preservative by a double vacuum process to provide a minimum service life of 25 years - so cannot be used for comparison purposes.

---

<sup>10</sup> UK Timber Research and Development Association



- Commonly used roof windows in NZ use Nordic pine, but for those windows the untreated wood is not exposed to the outside so they are not comparable.

## 5.6 The expert's conclusions

5.6.1 Although the joinery wood is vulnerable to decay in the event of leaks, the expert noted certain compensating features of the timber joinery, including (in summary):

- The wood is slightly more durable than untreated local pine, with preservative pre-treatment protecting at least the outer surface of the wood from decay.
- Coated aluminium extrusions at frame sash junctions will limit water reaching the gap and protect the sash glazing rebate at sill level, and drainage channels will drain any leaks past gaskets to the outside.
- Stainless steel sill top flashings will protect the sill timber, and the membrane seal between frames and concrete will give an additional line of defence.
- Although inspection cannot identify underlying defects, the proposed maintenance regime should keep coatings in good condition.

5.6.2 Providing drawings are satisfactorily revised, the expert considered that adding the following provisions may provide sufficient additional compensation to allow the proposal to demonstrate adequate durability:

- further high build coating to concealed parts of the joinery units, in particular to exposed end grain wood
- specific inspections during construction to ensure that drainage paths under sills are maintained
- checking glazing gaskets and seals as part of the maintenance regime
- taking periodic non-invasive and sample invasive moisture readings of frames and packers as part of the maintenance regime (refer applicant's response to draft at paragraph 4.5).

5.7 A copy of the expert's report was provided to the parties on 24 September 2012.

## 6. Establishing code compliance

6.1 In order for me to form a view as to code compliance of the timber joinery system, I have considered what test and technical evidence is available. In this case, reliable information is very limited and there is no documented history of use of the joinery's durability within New Zealand or comparable climatic zones elsewhere.

6.2 However, taking account of the expert's report and the other evidence, certain compensating factors apply to the timber joinery as it is proposed to be installed within this particular house. I have summarised the factors influencing durability in the following table:

Mitigating factors	
<b>The timber</b>	
<i>Pinus sylvestris</i> is classified as only 'slightly durable'.	<p><i>Pinus sylvestris</i> is more durable than <i>Pinus radiata</i> (classified 'not durable') but less durable than <i>Western red cedar</i> (classified 'durable').</p> <p>The TRADA classification applies to fast growth UK plantation Scots pine, which is generally lower than imported product grown in northern Europe.</p> <p>Nordic pine used for this joinery is likely to be more durable than the UK plantation wood.</p>
<p>Although there is some level of factory-applied surface treatment, it is unlikely to penetrate into untreated sapwood.</p> <p>The factory-applied paint coating is insufficient on some of the end grain.</p>	<p>Although the factory-applied preservative is not equivalent to H3, it will provide some level of protection to the outer surface of the wood.</p> <p>The factory-applied paint coatings will provide further protection to the surface of the joinery and a further coating system will be applied on-site.</p>
<b>The joinery design</b>	
If moisture penetrates into the timber, untreated sapwood will be vulnerable to decay.	<p>The joinery design will limit moisture penetration and drain any leaks to the outside.</p> <p>The joinery incorporates robust profiles that exceed minimum requirements of NZS 3610.</p> <p>The sample window will be site-tested.</p>
<b>The joinery installation</b>	
As part of the external envelope, the windows require a minimum durability of 15 years, 'with only normal maintenance'	<p>Joinery will include durable flashings to protect windows/doors and drain moisture to the outside.</p> <p>Joinery to concrete wall junctions are flashed with butyl rubber membrane, with air seals installed.</p> <p>The sample window installation will be site-tested for weathertightness.</p> <p>A detailed inspection and maintenance regime is intended to form part of the consent application, which exceeds 'normal maintenance and.</p>

6.3 Taking account of the expert's report, I accept that the following items also require attention in the application for this consent amendment:

- with regard to consent amendment drawings:
  - vulnerable capillary paths at head flashings
  - the inadequate anti-capillary gap between the cladding and head flashing
  - various missing notations, such as joinery profiles and timber species
  - missing window cross-references in the lower floor plan
  - various other minor omissions as noted in the expert's report
- with regard to the proposed maintenance regime, the inclusion of:
  - inspection of glazing gaskets and seals
  - periodic moisture testing of frames and sill packers
- with regard to construction:

- the inadequate coating to some exposed end grain wood
- specific inspection of drainage paths under sills.

## **6.4 The consequences of future failure**

- 6.4.1 Clause E2.3.2 of the Building Code requires that ‘Roofs and exterior walls must prevent the penetration of water that could cause undue dampness, damage to building elements, or both’. In addition to factors outlined above; I therefore need to assess risks applying to the particular circumstances of this building, which means considering the consequences of any possible future moisture penetration.
- 6.4.2 In regard to the risks and consequences of any future failure of the joinery system proposed for this particular house, I make the following observations:
- The outer weatherboard cladding is installed over a cavity to protect against any moisture penetrating the building wrap to structural battens and insulation.
  - The junction of the joinery unit with the concrete wall is protected with butyl rubber membrane, with air seals installed within the gap.
  - Should defects allow moisture penetration and damage to untreated wood in the timber joinery; the concrete walls would not be significantly affected, with damage likely to be limited to jamb linings and floor coverings.
- 6.4.3 Taking into account the above observations and providing the items outlined in paragraph 6.3 are appropriately included in the consent application, I have reasonable grounds to conclude that the proposed joinery system will remain adequately durable in order to meet the 15 year performance requirements of Clause B2 insofar as it relates to Clause E2.

## **7. Conclusion**

- 7.1 I acknowledge and support the authority with respect to the need to properly assess alternative solutions, and how these should be adequately documented when seeking consent for their use.
- 7.2 I have considered the criteria outlined in paragraph 6.2 together with the consequences described in paragraph 6.4.2. Providing items outlined in paragraph 6.3 are included in the consent application I am of the opinion that the combination of factors provides sufficient grounds for me to conclude that the timber joinery system proposed for this particular house will be able to achieve compliance with Clause B2 of the Building Code insofar as it applies to Clause E2.
- 7.3 I emphasise that each determination is conducted on a case-by-case basis. Accordingly, the fact that a particular joinery system has been established as being code-compliant in relation to a particular building does not necessarily mean that the same system will be code-compliant in another situation. This determination should on no account be taken as any form of product endorsement, appraisal or certification of the timber joinery units.

- 7.4 In the case of this joinery system, detailed and specific inspection and maintenance requirements will form part of the consent amendment. Effective maintenance of the joinery system will be important to ensure ongoing compliance with clauses B2 and E2 of the Building Code and is the responsibility of the building owner.

## **8. The decision**

- 8.1 In accordance with section 188 of the Building Act 2004, I hereby determine that the proposed timber joinery system as detailed in the application for amendment to the consent dated June 2012 does not comply with Clause B2 of the Building Code, and accordingly I confirm the authority's decision to refuse to grant an amendment to the building consent.

Signed for and on behalf of the Chief Executive of the Ministry of Business, Innovation and Employment on 23 October 2012.

John Gardiner  
**Manager Determinations**