

# Determination 2006/79

## Dispute about the addition of a fixed seat to a deck at 402A Rangi Avenue, Whangamata

---

**Applicant:** Thames Coromandel District Council (“the territorial authority”)  
**Owner:** Mr Murray Roberts (“the owner”)  
**Site Address:** 402A Rangi Avenue, Whangamata

---

### 1. The matter to be determined

1.1 This is a determination under Part 3 Subpart 1 of the Building Act<sup>1</sup> 2004 (“the Act”) made under due authorisation by me, John Gardiner, Determinations Manager, Department of Building and Housing (“the Department”), for and on behalf of the Chief Executive of that Department. The dispute arises because the territorial authority does not believe that the addition of a fixed seat to a deck, that would otherwise not require a barrier, complies with clause F4 “Safety from Falling” of the Building Code<sup>2</sup> (First Schedule, Building Regulations 1992).



**Figure 1: House elevation showing deck**

<sup>1</sup> The Building Act 2004 is available from the Department’s website at [www.dbh.govt.nz](http://www.dbh.govt.nz)

<sup>2</sup> The Building Code is available from the Department’s website at [www.dbh.govt.nz](http://www.dbh.govt.nz).

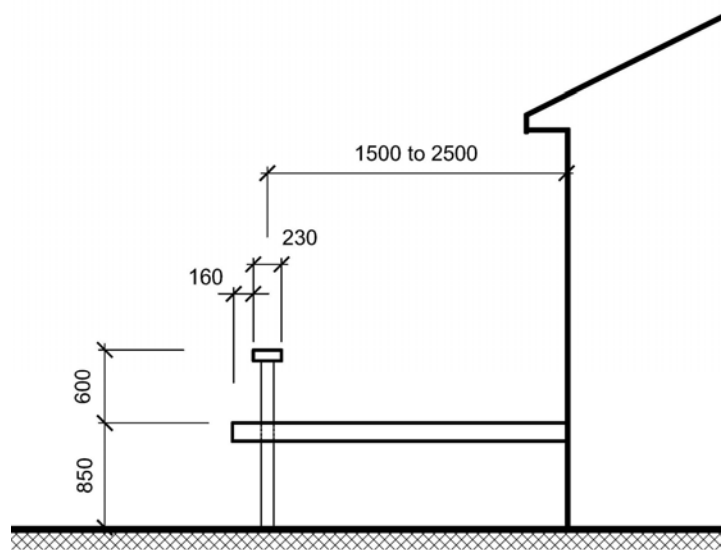

**Figure 2: Section through deck and seat**

## 2. The house, deck, and fixed seat

- 2.1 The owner built a 2-story house under a building consent ABA 20050043 issued by the territorial authority. The consented work included a deck adjacent to the ground floor living area as shown in elevation in Figure 1. The consent drawings supplied with the application are not dimensioned, but elsewhere in the application the deck is shown to be a maximum of 850mm above the adjacent ground level. No barrier is shown on the consented drawings and nor is one required as the deck is less than 1.0 metres above the ground.
- 2.2 The owner added a fixed seat to the perimeter edge of the deck, as shown in both Figures 1 and 2, as an additional item to the consented work. The fixed seat is approximately 230mm wide and finishes 600mm above the deck. The seat runs along the perimeter of the deck but set back from the edge of the deck by approximately 160mm. The total maximum distance from the top of the seat to the ground is 1450mm.
- 2.3 The owner sought a code compliance certificate from the territorial authority for the newly completed house which included the unconsented fixed seat to the deck.
- 2.4 The territorial authority referred the question of the code compliance of the fixed seat to the Department in an application received on 15 May 2006. The territorial authority submitted that:
- The deck is less than 1 [metre] in height and would not normally require a barrier under F4, Safety from Falling. Would the fixed seat change this situation?
- If so, would the top of the seat now be construed as the platform that would require protection from falling?
- . . . [if] the total distance from the top of the seat to the ground measures less than 1 [metre] Council believes this would be acceptable.
- 2.5 The application included a submission by the owner of the deck that said:
- [The seat had been installed] after seeking advice on Council requirements . . .

I feel that what I have built complies with [Council's] measurement[s] also giving some safety features . . .

### **3. Discussion**

- 3.1 The current Acceptable Solution for F4 (F4/AS1) does not address this situation. A proposed Acceptable Solution F4/AS1 was written by the Department's antecedent, the Building Industry Authority (BIA) and circulated for public comment. A final version of the proposed F4/AS1 was approved by the BIA in 2004. The proposed F4/AS1 has not yet been issued.
- 3.2 The proposed F4/AS1 (for housing) allows for a fixed seat to the edge of a deck where the ground to deck height is less than 1000mm and the deck to top of seat dimension is a maximum of 500mm, given that the ground to top of seat height must therefore be less than 1500mm.
- 3.3 Does the seat in this situation constitute a platform for which a barrier should be provided? The seat has a width of 230mm which is substantially less than the 400 mm maximum seat width allowed in the proposed F4/AS1. The total height of the fixed seat above the ground is 1450mm which is less than the 1500mm cumulative maximum dimension described in the proposed F4/AS1. In approving the proposed F4/AS1 the BIA obviously decided that a fixed seat did not constitute a hazard.
- 3.4 It is noted the seat is 600mm above the deck whereas the revised F4/AS1 allows a maximum of 500mm. However, given that the cumulative height is less than 1.5 metres, I am of the opinion that the 600mm height is not significant in this instance.
- 3.5 On this basis, I am satisfied that fixed seat does not constitute a platform and that the desk and seat will comply with the building code.

### **4. The decision**

- 4.1 In accordance with section 188 of the Act, I hereby determine:
- a) The fixed seat to the deck complies with clause F4 of the Building Code.

---

Signed for and on behalf of the Chief Executive of the Department of Building and Housing  
on 29 August 2006

John Gardiner  
**Determinations Manager**