

Compliance Document for New Zealand Building Code Clause E2 External Moisture

Prepared by the Department of Building and Housing

This Compliance Document is prepared by the Department of Building and Housing. The Department of Building and Housing is a Government Department established under the State Sector Act 1988.

Enquiries about the content of this document should be directed to:



Department of
Building and Housing
Te Tari Kaupapa Whare

Department of Building and Housing
PO Box 10-729, Wellington.
Telephone 0800 242 243
Fax 04 494 0290
Email: info@dbh.govt.nz

Compliance Documents are available from www.dbh.govt.nz

New Zealand Government

© Department of Building and Housing 2011

This Compliance Document is protected by Crown copyright, unless indicated otherwise. The Department of Building and Housing administers the copyright in this document. You may use and reproduce this document for your personal use or for the purposes of your business provided you reproduce the document accurately and not in an inappropriate or misleading context. You may not distribute this document to others or reproduce it for sale or profit.

The Department of Building and Housing owns or has licences to use all images and trademarks in this document. You must not use or reproduce images and trademarks featured in this document for any purpose (except as part of an accurate reproduction of this document) unless you first obtain the written permission of the Department of Building and Housing.

Status of Compliance Documents

Compliance Documents are prepared by the Department of Building and Housing in accordance with section 22 of the Building Act 2004. A Compliance Document is for use in establishing compliance with the New Zealand Building Code.

A person who complies with a Compliance Document will be treated as having complied with the provisions of the Building Code to which the Compliance Document relates. However, a Compliance Document is only one method of complying with the Building Code. There may be alternative ways to comply.

Users should make themselves familiar with the preface to the New Zealand Building Code Handbook, which describes the status of Compliance Documents and explains alternative methods of achieving compliance.

Defined words (italicised in the text) and classified uses are explained in Clauses A1 and A2 of the Building Code and in the Definitions at the start of this Compliance Document.

| E2: Document History | | | |
|---|--|--|---|
| | Date | Alterations | |
| First published | July 1992 | | |
| Second Edition | 28 February 1998 | Document revised – Second edition issued | |
| Third Edition | E2/VM1 effective from 1 July 2004 E2/AS1 effective from 1 February 2005 | | |
| Amendment 1 September 2004 | E2/AS1 effective from 1 July 2005 | p. 2 Document Status | |
| Reprinted incorporating Amendment 1 September 2004 | | | |
| Amendment 2 | Effective from 1 July 2005 | p. 2 Document History, Document Status pp. 5-7, 9, 10 Contents pp. 13-16 References pp. 17-20 Definitions pp. 21-24 E2/VM1 | pp. 25-43, 45-47, 49, 50, 55-57, 59-67, 69-89, 93-100, 102, 103, 105-107, 111-119, 121-125, 127-135, 138, 140-144, 146, 147, 149, 150, 153-155, 157, 163-169 E2/AS1 pp. 173, 174, 177, 178 Index |
| Erratum 1 | Effective from 1 December 2005 | p. 166 Table 23 | |
| Amendment 3 | 21 June 2007 | pp. 3 and 4, Building Code Clause E2 | |
| Amendment 4 | Effective from 1 May 2008 until 31 January 2012 | p. 2 Document History, Document Status pp. 8 and 12 Contents pp. 13-14 References | pp. 171-180 E2/AS2 p. 181 Index |
| Amendment 5 | 1 August 2011 | p. 2 Document History, Document Status pp. 5-12 Contents pp. 13-16A References pp. 17-20 Definitions pp. 21-24 E2/VM1 | pp. 25-180 E2/AS1 pp. 183-184, 189-190 E2/AS2 p. 191 E2/AS3 pp. 193-204 Index |
| Errata 2 | 24 December 2011 | p. 2 Document History, Document Status p. 9 Contents | pp. 29, 41, 43, 49, 55-57, 80, 81, 87, 91, 93, 94, 101, 106-108, 110-115, 117, 158, 160, 172, 176, 191 E2/AS1 |

Document Status

The most recent version of this document, as detailed in the Document History, is approved by the Chief Executive of the Department of Building and Housing.

E2 External Moisture Document Amendment 5 Errata 2 supersedes all previous versions from 1 February 2012, except for special provisions outlined in E2/VM1 Paragraph 1.5. E2 External Moisture Document Amendment 4 may also be used until 31 January 2012, except for special provisions outlined in E2/VM1 Paragraph 1.5 Amendment 5.

People using this Compliance Document should check for amendments on a regular basis. The Department of Building and Housing may amend any part of any Compliance Document at any time. Up-to-date versions of Compliance Documents are available from www.dbh.govt.nz

New Zealand Building Code Clause E2 External Moisture

This Clause is extracted from the New Zealand Building Code contained in the First Schedule of the Building Regulations 1992.

SR2007/124

Clause E2-External moisture

Provisions

Objective

E2.1 The objective of this provision is to safeguard people from illness or injury that could result from external moisture entering the *building*.

Functional requirement

E2.2 *Buildings* must be constructed to provide *adequate* resistance to penetration by, and the accumulation of, moisture from the outside.

Performance

E2.3.1 Roofs must shed precipitated moisture. In locations subject to snowfalls, roofs must also shed melted snow.

E2.3.2 Roofs and exterior walls must prevent the penetration of water that could cause undue dampness, damage to *building elements*, or both.

E2.3.3 Walls, floors, and structural elements in contact with, or in close proximity to, the ground must not absorb or transmit moisture in quantities that could cause undue dampness, damage to *building elements*, or both.

E2.3.4 *Building elements* susceptible to damage must be protected from the adverse effects of moisture entering the space below suspended floors.

E2.3.5 *Concealed spaces* and cavities in *buildings* must be constructed in a way that prevents external moisture being accumulated or transferred and causing condensation, fungal growth, or the degradation of *building elements*.

Limits on application

Requirement E2.2 does not apply to *buildings* (for example, certain bus shelters, and certain *buildings* used for horticulture or for equipment for washing motor vehicles automatically) if moisture from the outside penetrating them, or accumulating within them, or both, is unlikely to impair significantly all or any of their *amenity*, durability, and stability.

SR2007/124

Provisions*Performance*

E2.3.6 Excess moisture present at the completion of *construction* must be capable of being dissipated without permanent damage to *building elements*.

E2.3.7 *Building elements* must be constructed in a way that makes due allowance for the following:

- (a) the consequences of failure;
- (b) the effects of uncertainties resulting from *construction* or from the sequence in which different aspects of *construction* occur;
- (c) variation in the properties of materials and in the characteristics of the site.

Limits on application

Contents

| | | Page | |
|---------------------|--|-------------|---------------------|
| | References | 13 | |
| | Definitions | 17 | |
| | Verification Method E2/VM1 | 21 | |
| | 1.0 Cladding systems of buildings, including junctions with windows, doors and other penetrations | 21 | |
| | 1.1 General | 21 | |
| | 1.2 Scope | 21 | |
| | 1.3 Specimen details | 21 | |
| | 1.4 Test procedure | 22 | |
| | 1.4.1 Preconditioning | 22 | |
| Amend 2 Jul 2005 | 1.4.2 Series 1 Static pressure water penetration | 22 | |
| Amend 2 Jul 2005 | 1.4.3 Series 1 Cyclic pressure water penetration | 22 | |
| | 1.4.4 Series 2 'Water management testing' | 22 | |
| Amend 5 Aug 2011 | 1.4.5 Series 3 'Wetwall test' | 23 | |
| | 1.5 Transition period for existing verification certificates as at 31 August 2011 | 23 | |
| Amend 2 Jul 2005 | 1.6 Pro-forma for test details | 23 | |
| | 2.0 Pitched roofing systems over a ventilated roof space of 15° pitch or more | 23 | |
| | 3.0 Skillion roofs and commercial and industrial roofing | 23 | |
| | Appendix 1: Pro forma | 24 | |
| | Acceptable Solution E2/AS1 | 25 | |
| | 1.0 Scope | 25 | |
| | 1.1 Construction included | 25 | |
| Amend 5 Aug 2011 | 1.1.1 Attached garages | 25 | |
| | 1.2 Construction excluded | 25 | |
| | 1.2.1 Outbuildings | 25 | |
| | 1.2.2 Spread of flame | 25 | |
| Amend 2 Jul 2005 | 1.2.3 Acoustics | 25 | |
| | 1.3 Provisions for snow | 25 | |
| | 1.4 Specific design | 26 | Amend 2 Jul 2005 |
| | 1.5 Qualifications | 26 | |
| | 2.0 General | 26 | |
| | 2.1 Weathertightness | 26 | |
| | 2.2 Materials | 26 | |
| | 2.3 Systems versus materials | 26 | |
| | 2.4 Cladding finish colours | 26 | |
| | 2.5 Maintenance – general | 27 | |
| | 2.5.1 Regular maintenance | 27 | Amend 5 Aug 2011 |
| | 3.0 Weathertightness Risk Factors | 27 | |
| | 3.1 Establishing the risk | 27 | |
| | 3.1.1 Definitions of risk | 27 | |
| | 3.1.2 The risk score | 27 | |
| | 3.3 Wall claddings | 28 | |
| | 3.4 Examples using the risk matrix | 32 | |
| | 3.4.1 Example 1 | 32 | |
| | 3.4.2 Example 2 | 33 | |
| | 3.4.3 Example 3 | 34 | |
| | 4.0 Flashings | 35 | |
| | 4.1 Materials for flashings | 35 | |
| | 4.2 Selection of flashing materials | 35 | |
| | 4.2.1 Environment | 35 | |
| | 4.2.2 Surrounding materials | 36 | |
| | 4.3 Acceptable flashing materials | 36 | |
| | 4.3.1 uPVC flashings | 36 | |
| | 4.3.2 Aluminium flashings | 36 | |
| | 4.3.3 Galvanized steel flashings | 36 | |
| | 4.3.4 Aluminium-zinc coated steel flashings | 36 | |
| | 4.3.5 Stainless steel flashings | 37 | |
| | 4.3.6 Copper flashings | 37 | |
| | 4.3.7 Lead sheet flashings | 37 | |
| | 4.3.8 Zinc sheet flashings | 37 | |
| | 4.3.9 Butyl rubber and EPDM flashings | 37 | |
| | 4.3.10 Bituminous flashings | 37 | Amend 5 Aug 2011 |

| | | | |
|---|-----------|---|-----------|
| 4.3.11 Flexible flashing tape | 37 | 8.1.2 Limitations | 59 |
| 4.4 Fixings | 37 | 8.1.3 Maintenance | 59 |
| 4.5 Flashing requirements | 37 | 8.1.4 Fixings | 59 |
| 4.5.1 Edge treatments for flashings | 37 | 8.1.5 Roof underlays | 59 |
| 4.5.2 Metal flashing joints | 38 | 8.1.6 Gutters general | 60 |
| 4.6 Flashing overlaps and upstands | 39 | 8.1.7 Roof penetrations | 61 |
| 4.6.1 Overlap with roof claddings | 39 | 8.2 Masonry Tiles | 63 |
| 5.0 Roof/Wall Junctions | 42 | 8.2.1 Materials | 63 |
| 5.1 Apron flashings | 42 | 8.2.2 General | 63 |
| 5.2 Gutters, barges and fascias | 44 | 8.2.3 Installation | 63 |
| 5.3 Soffits | 44 | 8.2.4 Flashings and fixings | 63 |
| 6.0 Parapets | 45 | 8.2.5 Anti-ponding boards | 63 |
| 6.1 Limitations | 45 | 8.2.6 Details and flashings | 63 |
| 6.2 General | 45 | 8.2.7 Penetrations | 66 |
| 6.3 Capping materials | 45 | 8.3 Pressed Metal Tiles | 68 |
| 6.4 Metal cappings | 47 | 8.3.1 Limitations | 68 |
| 6.4.1 Parapet-to-wall junctions | 48 | 8.3.2 Installation | 68 |
| 6.5 Membrane cappings | 48 | 8.3.3 Tiles | 68 |
| 6.6 Integral surface cappings | 48 | 8.3.4 Metal substrate | 68 |
| 7.0 Decks and Pergolas | 51 | 8.3.5 Roof pitch | 68 |
| 7.1 Thresholds for decks | 51 | 8.3.6 Underlay | 69 |
| 7.1.1 Slatted decks | 51 | 8.3.7 Fixings | 69 |
| 7.1.2 Enclosed decks | 51 | 8.3.8 Flashings | 69 |
| 7.2 Attachment to building structure | 51 | 8.3.9 Gutters, ridges, barges and fascias | 72 |
| 7.2.1 Slatted timber decks to walls | 51 | 8.3.10 Roof penetrations | 72 |
| 7.2.2 Pergolas | 52 | 8.4 Profiled Metal Roof Cladding | 73 |
| 7.3 Level threshold | 54 | 8.4.1 Limitations | 73 |
| 7.3.1 Enclosed decks | 54 | 8.4.2 General | 73 |
| 7.3.2 Ground floor level access | 54 | 8.4.3 Materials | 73 |
| 7.4 Enclosed balustrades | 57 | 8.4.4 Profiles | 74 |
| 7.4.1 Deck drainage | 57 | 8.4.5 Roof pitch | 74 |
| 7.4.2 Balustrade-to-wall junctions | 57 | 8.4.6 Structure | 74 |
| 7.4.3 Balustrade-to-deck floor junction | 57 | 8.4.7 Underlay | 76 |
| 7.4.4 Metal cappings | 57 | 8.4.8 Fixings: corrugated and trapezoidal | 76 |
| 7.4.5 Stanchions | 58 | 8.4.9 Fixings: trough profile | 78 |
| 8.0 Roof Claddings | 59 | 8.4.10 Allowance for expansion | 78 |
| 8.1 General | 59 | 8.4.11 Flashing requirements | 78 |
| 8.1.1 Weathertightness | 59 | | |

Amend 5
Aug 2011Amend 2
Jul 2005Amend 5
Aug 2011

| | | | |
|--|------------|---|------------|
| 8.4.12 Flashing details | 79 | 9.2.8 Control joints | 115 |
| 8.4.13 Stopends | 84 | 9.2.9 Openings in masonry veneer | 115 |
| 8.4.14 Turn-downs at gutters | 84 | 9.2.10 Windows and doors | 116 |
| 8.4.15 Profile closure | 84 | 9.2.11 Secondary cladding | 116 |
| 8.4.16 Hidden, valley and internal gutters | 84 | 9.3 Stucco | 117 |
| 8.4.17 Roof penetrations | 86 | 9.3.1 Limitations | 117 |
| 8.5 Membrane Roofs and Decks | 89 | 9.3.2 Structure | 117 |
| 8.5.1 Limitations | 89 | 9.3.3 Stucco cladding system | 117 |
| 8.5.2 General | 89 | 9.3.4 Installation | 117 |
| 8.5.3 Plywood substrates | 89 | 9.3.5 Non-rigid plaster backings | 118 |
| 8.5.4 Butyl and EPDM | 89 | 9.3.6 Rigid plaster backings | 118 |
| 8.5.5 Installation | 90 | 9.3.7 Finishes | 118 |
| 8.5.6 Roof and deck drainage | 90 | 9.3.8 Bottom of stucco | 118 |
| 8.5.7 Control joints | 91 | 9.3.9 Parapets and enclosed balustrades | 118 |
| 8.5.8 Junctions | 92 | 9.3.10 Windows and doors | 118 |
| 8.5.9 Penetrations | 92 | 9.4 Timber Weatherboards | 121 |
| 8.5.10 Gutters | 93 | 9.4.1 Limitations | 121 |
| 9.0 Wall Claddings | 97 | 9.4.2 Materials | 121 |
| 9.1 General | 97 | 9.4.3 Installation | 121 |
| 9.1.1 Limitations | 97 | 9.4.4 Horizontal weatherboards | 121 |
| 9.1.2 Maintenance | 97 | 9.4.5 Vertical weatherboards | 124 |
| 9.1.3 Bottom of cladding | 97 | 9.4.6 Windows and doors in direct fixed weatherboards | 125 |
| 9.1.4 Barriers to airflow | 98 | 9.4.7 Windows and doors in cavity walls | 125 |
| 9.1.5 Wall underlays to wall openings | 99 | 9.4.8 Parapets and enclosed balustrades | 132 |
| 9.1.6 Air seals | 99 | 9.4.9 Finishes | 132 |
| 9.1.7 Wall underlay | 99 | 9.5 Fibre Cement Weatherboards | 133 |
| 9.1.8 Drained cavities | 100 | 9.5.1 Limitations | 133 |
| 9.1.9 Penetrations | 101 | 9.5.2 Material performance | 133 |
| 9.1.10 Windows and doors | 103 | 9.5.3 Installation | 133 |
| 9.2 Masonry Veneer | 108 | 9.5.4 Windows and doors | 134 |
| 9.2.1 Limitations | 108 | 9.5.5 Parapets and enclosed balustrades | 134 |
| 9.2.2 General | 108 | 9.5.6 Protective coating | 134 |
| 9.2.3 Installation | 108 | 9.6 Profiled Metal Wall Cladding | 138 |
| 9.2.4 Flashings | 108 | 9.6.1 Limitations | 138 |
| 9.2.5 Foundation support and damp proofing | 113 | 9.6.2 General | 138 |
| 9.2.6 Cavities | 113 | 9.6.3 Materials | 138 |
| 9.2.7 Wall ties | 114 | | |

Amend 5
Aug 2011

Amend 2
Jul 2005

Amend 5
Aug 2011

| | | | | |
|------------|--|------------|-----------------------------------|--|
| 9.6.4 | Maintenance | 138 | | |
| 9.6.5 | Profiles | 139 | | |
| 9.6.6 | Fixing | 139 | | |
| 9.6.7 | Flashings | 139 | | |
| 9.6.8 | Vertical profile – direct fixed | 139 | | |
| 9.6.9 | Horizontal profiled metal on cavity | 143 | | |
| 9.7 | Fibre Cement Sheet | 148 | | |
| 9.7.1 | Limitations | 148 | | |
| 9.7.2 | Material and installation – both systems | 148 | | |
| 9.7.3 | Jointed systems | 148 | | |
| 9.7.4 | Flush-finished systems | 152 | | |
| 9.7.5 | Soffit details | 153 | | |
| 9.7.6 | Windows and doors | 153 | | |
| 9.7.7 | Parapets and enclosed balustrades | 153 | | |
| 9.7.8 | Decorative attachments | 159 | | |
| 9.8 | Plywood Sheet | 160 | | |
| 9.8.1 | Limitations | 160 | | |
| 9.8.2 | Materials | 160 | | |
| 9.8.3 | Installation | 160 | | |
| 9.8.4 | Corners | 161 | | |
| 9.8.5 | Flashing material | 161 | | |
| 9.8.6 | Soffit details | 161 | | |
| 9.8.7 | Parapets and enclosed balustrades | 161 | | |
| 9.8.8 | Windows and doors | 161 | | |
| 9.8.9 | Finishes | 161 | | |
| 9.9 | EIFS | 163 | | |
| 9.9.1 | Limitations | 163 | | |
| 9.9.2 | General | 163 | | |
| 9.9.3 | Materials | 163 | | |
| 9.9.4 | Installation | 163 | | |
| 9.9.5 | Battens | 165 | | |
| 9.9.6 | Coating | 165 | | |
| 9.9.7 | EIFS/floor slab junction | 166 | | |
| 9.9.8 | Pipes and service penetrations | 166 | | |
| 9.9.9 | Windows and doors | 167 | | |
| 9.9.10 | Parapets and enclosed balustrades | 167 | | |
| | | | 10.0 | Construction Moisture |
| | | | | 171 |
| | | | 10.1 | Moisture in materials |
| | | | | 171 |
| | | | 10.2 | Maximum acceptable moisture contents |
| | | | | 171 |
| | | | 10.3 | Measuring moisture content |
| | | | | 171 |
| | | | 10.3.1 | Timber |
| | | | | 171 |
| | | | 10.3.2 | Concrete floors |
| | | | | 171 |
| | | | Acceptable Solution E2/AS2 | 181 |
| | | | 1.0 | Earth buildings |
| | | | | 181 |
| | | | 1.1 | Modifications to NZS 4299 |
| | | | | 181 |
| | | | Acceptable Solution E2/AS3 | 191 |
| | | | 1.0 | Concrete and concrete masonry buildings |
| | | | | 191 |

Amend 5
Aug 2011Amend 4
May 2008

Tables

Amend 5
Aug 2011

| | |
|---|-----|
| Table 1: Definitions of risk levies | 29 |
| Table 2: Building envelope risk matrix | 30 |
| Table 3: Suitable wall claddings | 31 |
| Table 4: Risk matrix example 1 – south face | 32 |
| Table 5: Risk matrix example 2 – south elevation | 33 |
| Table 6: Risk matrix example 3 – south elevation | 34 |
| Table 7: Metal flashings – general dimensions | 40 |
| Table 8: Maximum catchment areas for valley gutters | 61 |
| Table 9: Maximum catchment areas above penetrations | 62 |
| Table 10: Minimum pitches for masonry tiles | 63 |
| Table 11: Steel corrugate profiled roofing – 0.4 mm BMT and minimum profile height 16.5 mm | 75 |
| Table 12: Steel corrugate profiled roofing – 0.55 mm BMT with minimum profile height 16.5 mm | 75 |
| Table 13: Steel trough profile roofing – 0.55 mm BMT with profile height 46 mm minimum, and pan width 210 mm maximum | 76 |
| Table 14: Steel trapezoidal profiled roofing – 0.4 mm BMT and profile height 27 mm minimum and minimum 5-rib profiles | 77 |
| Table 15: Steel trapezoidal profiled roofing – 0.55 mm BMT, profile height 27 mm minimum and minimum 5-rib profiles | 77 |
| Table 16: Expansion provisions | 78 |
| Table 17: Catchment areas for profiled metal | 86 |
| Table 18: Minimum clearances | 97 |
| Table 18A: Specifications of maximum tie spacings for type B veneer ties | 114 |

Amend 2
Jul 2005

Errata 2
Dec 2011

| | |
|---|-----|
| Table 18B: Placement of wall ties | 114 |
| Table 18C: Corrosion protection to masonry wall ties | 115 |
| Table 18D: Corrosion protection to lintels | 115 |
| Table 18E: Masonry veneer lintel sizes (minimum) | 116 |
| Table 19: Control joints for flush-finished fibre cement | 153 |
| Table 20: Material selection | 172 |
| Table 21: Compatibility of materials in contact | 174 |
| Table 22: Compatibility of materials subject to run-off | 175 |
| Table 23: Properties of roof underlays and wall underlays | 176 |
| Table 24: Fixing selection for wall claddings | 177 |

Figures

| | |
|---|----|
| Figure 1: How to assess risk | 28 |
| Figure 2: Risk matrix example 1 | 32 |
| Figure 3: Risk matrix example 2 | 33 |
| Figure 4: Risk matrix example 3 | 34 |
| Figure 5: Typical metal flashing edge treatments | 38 |
| Figure 6: Joints in metal flashings | 38 |
| Figure 7: Basic apron flashing | 42 |
| Figure 8A: Soffit/wall junction | 43 |
| Figure 8B: Gutter/wall junction | 44 |
| Figure 9: General capping joints for parapets and enclosed balustrades | 46 |
| Figure 10: General construction of parapet and enclosed balustrade | 47 |
| Figure 11: Parapet/enclosed balustrade-to-wall junctions – plan section | 49 |
| Figure 12: General junction of parapet and enclosed balustrade to wall | 50 |
| Figure 14: Threshold separations | 51 |
| Figure 15: Junction with wall for non-cantilevered timber deck | 52 |

Errata 2
Dec 2011

Amend 5
Aug 2011

| | | | |
|--|-----|--|-----|
| Figure 16: Junction with wall for cantilevered timber deck | 53 | Figure 43: Ridge to hip flashings | 80 |
| Figure 17A: Level thresholds for enclosed decks | 55 | Figure 44: Apron flashing and change in pitch for profiled metal | 80 |
| Figure 17B: Level thresholds for ground level | 56 | Figure 45: Eaves and roof/wall ridge for profiled metal | 81 |
| Figure 17C: Door sills for cavity construction | 56A | Figure 46: Ridge and hip flashings for profiled metal | 81 |
| Figure 17D: Door sills for direct fix | 56B | Figure 47: Barge flashings for profiled metal | 82 |
| Figure 18: Enclosed balustrade – bottom of cladding | 57 | Figure 48: Parallel apron flashings for profiled metal | 83 |
| Figure 19: Stanchion fixing | 58 | Figure 49: Profiled metal stopends | 84 |
| Figure 20: Spreader for roof discharge | 60 | Figure 50: Parallel hidden gutter for profiled metal | 85 |
| Figure 21: Penetration support | 62 | Figure 51: Valley gutters for profiled metal | 85 |
| Figure 22: Catchment area for penetrations | 62 | Figure 52: Internal gutter for profiled metal | 86 |
| Figure 23: Masonry tile ridge | 64 | Figure 53: Flashing for small pipes | 87 |
| Figure 24: Barge for masonry tile | 64 | Figure 54: Soaker flashing for pipe penetrations | 87 |
| Figure 25: Timber fascia eaves for masonry tile | 65 | Figure 55: Soaker flashing for other penetrations | 88 |
| Figure 26: Apron details for masonry tile | 65 | Figure 56: Falls in membrane roofs and decks | 91 |
| Figure 27: Valley for masonry tile | 66 | Figure 57: External corner in upstand | 91 |
| Figure 28: Roof/wall ridge for masonry tile | 66 | Figure 58: Internal corner in upstand | 92 |
| Figure 29: Pipe penetration for masonry tile | 66 | Figure 59: Roofing penetration in membrane | 92 |
| Figure 30: Abutment at framed penetration for masonry tile | 67 | Figure 60: Pipe penetration in membrane | 92 |
| Figure 31: Flashing to framed penetration for masonry tile | 67 | Figure 61: Verges in membrane | 93 |
| Figure 32: Metal tile profiles | 68 | Figure 62: Junctions with walls for membrane | 94 |
| Figure 33: Metal tile fixings | 69 | Figure 63: Rainwater head and scupper opening in membrane | 95 |
| Figure 34: Ridge or hip flashings for metal tile | 70 | Figure 64: Gutters and outlets in membrane | 96 |
| Figure 35: Apron flashings for metal tile | 70 | Figure 65: Levels and garage openings | 97 |
| Figure 36: Eaves and barge for metal tile | 71 | Figure 66: Cavity base closer/vermin proofing | 100 |
| Figure 37: Hidden and valley gutter flashings for metal tile | 71 | Figure 67: Cavity spacers | 100 |
| Figure 38: Profiled metal profiles | 74 | Figure 68: General pipe penetration | 102 |
| Figure 39: Corrugated and trapezoidal fixings and sheet lap | 77 | Figure 69: General meterbox and similar penetrations | 103 |
| Figure 40: Typical trough profile fixings | 78 | Figure 70: General inter-storey junction | 103 |
| Figure 41: Soft edge flashing | 79 | Figure 71: General sealing of head flashing | 104 |
| Figure 42: Trapezoidal notched flashing | 79 | | |

Amend 2
Jul 2005Amend 2
Jul 2005Amend 2
Jul 2005Amend 5
Aug 2011Amend 5
Aug 2011

| | | | |
|--|-----|---|-----|
| Figure 72A: General window and door opening for direct fixed | 106 | Figure 89: Aluminium corners in fibre cement weatherboards | 135 |
| Figure 72B: General window and door opening with drainage cavity | 107 | Figure 90: Windows and doors in fibre cement direct fixed weatherboards | 136 |
| Figure 73A: Vertical control joint | 108 | Figure 91: Windows and doors in fibre cement weatherboards on cavity | 137 |
| Figure 73B: Masonry veneer height limitations | 109 | Figure 92: Barge for vertical profiled metal | 140 |
| Figure 73C: Masonry veneer window and door installation | 110 | Figure 93: Bottom of cladding for vertical profiled metal | 140 |
| Figure 73D: Masonry veneer details | 111 | Figure 94: Corners for vertical profiled metal | 141 |
| Figure 73E: Masonry veneer details | 112 | Figure 95: Windows and doors for vertical profiled metal | 142 |
| Figure 74: Types of stucco cladding | 117 | Figure 96: Corner flashings for horizontal profiled metal | 143 |
| Figure 75: Bottom of stucco cladding | 119 | Figure 97: Barge for horizontal profiled metal | 144 |
| Figure 76: Windows and doors in stucco cladding | 120 | Figure 98: Bottom of cladding | 144 |
| Figure 77: Corner soakers for bevel-back weatherboards | 122 | Figure 99: Windows and doors for horizontal profiled metal on cavity | 145 |
| Figure 78: External corners for horizontal weatherboards | 123 | Figure 100: Window and door flashings for profiled metal | 146 |
| Figure 79: Internal corners for horizontal or vertical weatherboards | 124 | Figure 101: Balustrade for vertical profiled metal | 147 |
| Figure 80: External corners for vertical weatherboards | 125 | Figure 102: Balustrade for horizontal profiled metal | 147 |
| Figure 81: Windows and doors for direct fixed bevel-back weatherboards | 126 | Figure 104A: Vertical uPVC joints for fibre cement sheet | 149 |
| Figure 82: Windows and doors for direct fixed rusticated weatherboards | 127 | Figure 104B: Internal corners for fibre cement sheet | 149 |
| Figure 83: Windows and doors for direct fixed vertical shiplap weatherboards | 128 | Figure 105: Vertical timber batten joints for fibre cement sheet | 150 |
| Figure 84: Windows and doors for direct fixed board and batten weatherboards | 129 | Figure 107: Horizontal joints for direct fixed fibre cement | 151 |
| Figure 85: Windows and doors for bevel-back weatherboards on cavity | 130 | Figure 108: Horizontal joints for fibre cement sheet on cavity | 152 |
| Figure 86: Windows and doors for rusticated weatherboards on cavity | 131 | Figure 110: Flush-finished joints for fibre cement sheet | 153 |
| Figure 87: Joints in fibre cement weatherboards | 133 | | |
| Figure 88: External corners in fibre cement weatherboards | 134 | | |

Amend 5
Aug 2011

Amend 5
Aug 2011

| | | | |
|--|-----|---|-----|
| Figure 111: Vertical movement control joint for flush-finished fibre cement sheet | 154 | Figure 9.2: Head details | 185 |
| Figure 113: Flush-finished external corners for fibre cement sheet | 155 | A) Timber joinery with timber-framed wall insert | 185 |
| Figure 114: Soffits for flush-finished fibre cement sheet | 155 | B) Aluminium joinery with timber-framed wall insert | 185 |
| Figure 115: Windows and doors for direct fixed fibre cement sheet | 156 | C) Timber joinery with timber lintel | 186 |
| Figure 116: Windows and doors for fibre cement sheet and flush-finished fibre cement on cavity | 157 | D) Aluminium joinery with timber lintel | 186 |
| Figure 117: Enclosed balustrade to wall for fibre cement sheet | 158 | Figure 9.3: Jamb details | 187 |
| Figure 119: Battened joints for plywood sheet | 160 | A) Timber joinery | 187 |
| Figure 121: Horizontal joints for plywood sheet | 161 | B) Aluminium joinery | 187 |
| Figure 122: External corners for plywood sheet | 162 | Figure 9.4: Sill details | 188 |
| Figure 123: Internal corners for plywood sheet | 162 | A) Timber joinery with brick or tile sill | 188 |
| Figure 124: Control joints for EIFS | 164 | B) Aluminium joinery with brick or tile sill | 188 |
| Figure 125: Bottom of cladding for EIFS | 166 | C) Timber joinery with concrete sill | 189 |
| Figure 126: Penetration for EIFS | 166 | D) Aluminium joinery with concrete sill | 189 |
| Figure 127: Window and door corner flashing for EIFS | 168 | | |
| Figure 128: Windows and doors in EIFS | 169 | | |
| Figure 129: Enclosed balustrade-to-wall junction for EIFS | 170 | | |
| Figure 130: Parapet with metal capping for EIFS | 170 | | |
| | | | |
| Figures – E2/AS2 | | | |
| Figure 4.1: Footing dimensions and general details | 181 | | |
| Figure 5.11: Soffit to wall junction | 182 | | |
| A) Flat soffit | 183 | | |
| B) Angled soffit | 183 | | |
| Figure 5.12: Timber-framed gable to earth wall | 184 | | |

Amend 4
May 2008Amend 5
Aug 2011

References

For the purposes of New Zealand Building Code (NZBC) compliance, the Standards and documents referenced in this Compliance Document (primary reference documents) must be the editions, along with their specific amendments, listed below. Where these primary reference documents refer to other Standards or documents (secondary reference documents), which in turn may also refer to other Standards or documents, and so on (lower-order reference documents), then the version in effect at the date of publication of this Compliance Document must be used.

Amend 4
May 2008

Standards New Zealand

Amend 5
Aug 2011

AS/NZS 1734: 1997 Aluminium and aluminium alloys – Flat sheet, coiled sheet and plate

Where quoted

AS1 4.3.2, 8.3.4.3,
8.4.3.3, 9.6.3.3

Amend 2
Jul 2005

AS/NZS 2269.0: 2008 Plywood – Structural

AS1 8.5.3,
9.3.6.1, 9.8.2

NZS 2295: 2006 Pliable, Permeable Building Membranes

AS1 8.1.5, Table 23

Amend 5
Aug 2011

AS/NZS 2728: 2007 Prefinished/prepainted sheet metal products for interior/exterior building applications – Performance requirements

AS1 4.2.1, 8.3.4.1,
8.3.4.2, 8.3.4.3,
8.4.3.1, 8.4.3.3, 9.6.3.1,
9.6.3.3, Table 20

Amend 5
Aug 2011

AS/NZS 2904: 1995 Damp-proof courses and flashings

AS1 4.3.10, 9.2.4

AS/NZS 2908: Cellulose-cement products
Part 2: 2000 Flat sheet

AS1 9.3.6.2, 9.5.2,
9.7.2

NZS 3602: 2003 Timber and wood-based products for use in building

AS1 9.1.10, 9.4.2,
9.4.9, 9.7.3, 9.8.2,
10.2, Table 23

NZS 3604: 2011 Timber framed buildings

Definitions, VM1 1.1, 1.2,
AS1 1.1, 1.3, 4.1.3, 4.2.1,
7.2.1, 8.3.4.1, 8.4.3.1,
8.5.1, 9.1.3.1, 9.1.3.5,
9.2.1, 9.2.3, 9.2.7.1,
9.2.9, 9.3.2, 9.6.3.1,
Table 1, Table 2, Table 4,
Table 5, Table 6, Table 18,
Table 18A, Table 20
and Table 24

Amend 4
May 2008

Amend 5
Aug 2011

NZS 3617: 1979 Specification for profiles of weatherboards, fascia boards, and flooring

AS2 Figure 5.11 a) and b)

AS1 9.4.1.1

AS/NZS 4020: 2005 Testing of products for use in contact with drinking water

AS1 8.1.1

Amend 5
Aug 2011

| | | Where quoted |
|---------------------|---|--|
| Amend 5 Aug 2011 | NZS 4206: 1992 Concrete interlocking roofing tiles | AS1 8.2.1, 8.2.3 |
| Amend 5 Aug 2011 | NZS 4211: 2008 Specification for performance of windows | VM1 1.2, AS1 9.1.10 |
| | NZS 4217 Pressed metal tile roofs | AS1 8.3.3 |
| | Part 1: 1980 Specification for roofing tiles and their accessories | |
| | Part 2: 1980 Code of practice for preparation of the structure and the laying and fixing of metal roofing tiles | |
| Amend 5 Aug 2011 | SNZ HB 4236: 2002 Masonry veneer wall cladding | Definitions, AS1 Table 3 |
| | NZS 4251: Solid plastering | |
| Amend 5 Aug 2011 | Part 1: 2007 Cement plasters for walls, ceilings and soffits | AS1 9.3.2, 9.3.4.1, 9.3.4.2, 9.3.6.1, 9.3.6.2 |
| | AS/NZS 4256 Plastic roof and wall cladding materials | AS1 4.3.1 |
| | Part 2: 1994 Unplasticized polyvinyl chloride (uPVC) building sheets | |
| Amend 5 Aug 2011 | AS/NZS 4284: 2008 Testing of Building Facades | VM1 1.1, 1.4, 1.4.2, 1.4.3, 1.4.4 |
| | NZS 4298: 1998 Materials and workmanship for earth buildings <i>Amend: 1</i> | AS2 5.1.8, 9.7.2, Figure 4.1, Figure 9.2 a), b), c) and d) |
| | NZS 4299: 1998 Earth buildings not requiring specific design <i>Amend: 1</i> | AS2 1.0, 1.1 |
| | NZS 4431: 1989 Code of practice for earth fill for residential development <i>Amend: 1</i> | AS2 Figure 4.1 |
| Amend 4 May 2008 | AS/NZS 4534: 2006 Zinc and zinc/aluminium-alloy coatings on steel wire | AS1 9.1.8.5 |
| Amend 5 Aug 2011 | AS/NZS 4680: 2006 Hot-dip galvanized (zinc) coatings on fabricated ferrous articles | AS1 9.9.4.1, Table 20 |
| Amend 5 Aug 2011 | AS/NZS 4858: 2004 Wet area membranes | AS1 9.7.7.1, 9.9.4.4, 9.9.10.1 |

| | | Where quoted |
|--------------------------------------|---|--|
| Standards Australia | | |
| | AS 1366 Rigid cellular plastics sheets for thermal insulation | |
| | Part 3: 1992 Rigid cellular polystyrene – Moulded (RC/PS-M) | AS1 9.9.3.1 |
| | Part 4: 1989 Rigid cellular polystyrene – Extruded (RC/PS-E) | AS1 9.9.3.1 |
| Amend 5 Aug 2011 | AS 1397: 2001 Steel sheet and strip – Hot-dip zinc-coated or aluminium/zinc-coated | AS1 Table 20 |
| | AS 1566: 1997 Copper and copper alloys – Rolled flat products | AS1 4.3.6 |
| | AS 1804: 1976 Soft lead sheet and strip | AS1 4.3.7 |
| | AS 2049: 2002 Roof tiles | AS1 8.2.1 |
| | AS 2050: 2002 Installation of roof tiles | AS1 8.2.3 |
| | AS 3566 Self-drilling screws for the building and construction industries | |
| Amend 5 Aug 2011 | Part 2: 2002 Corrosion resistance | AS1 8.4.8, 8.4.9, 9.6.6, Table 20 |
| Amend 5 Aug 2011 | AS 3730 Guide to the properties of paints for buildings | AS1 9.3.7, 9.4.9, 9.5.6, 9.7.3.1, 9.7.4, 9.8.9, 9.9.3, 9.9.6.3 |
| Amend 5 Aug 2011 | Part 6: 2006 Solvent-borne – Exterior – Full gloss enamel | |
| | Part 7: 2006 Latex – Exterior – Flat | |
| | Part 8: 2006 Latex – Exterior – Low-gloss | |
| Amend 2 Jul 2005 | Part 9: 2006 Latex – Exterior – Semi-gloss | |
| | Part 10: 2006 Latex – Exterior – Gloss | |
| | AS 4046 Methods of testing roof tiles | |
| Amend 5 Aug 2011 | Part 9: 2002 Determination of dynamic weather resistance | VM1 2.1, AS1 8.2.3 |
| British Standards Institution | | |
| | BS 6538: 1987 Air permeance of paper and board | |
| | Part 3: 1987 Method for determination of air permeance using the Garley apparatus | AS1 Table 23 |
| Amend 5 Aug 2011 | BS EN 988: 1997 Zinc and zinc alloys. Specification for rolled flat products for building | AS1 4.3.8 |

| | | Where quoted |
|---|--|---------------------|
| American Society for Testing and Materials | | |
| Amend 5 Aug 2011 | ASTM C1549: 2009 Standard Test Method for Determination of Solar Reflectance Near Ambient Temperature Using a Portable Solar Reflectometer | AS1 2.4 |
| Amend 5 Aug 2011 | ASTM D1667: 2005 Standard Test Specification for Flexible Cellular Materials – Vinyl Chloride Polymers and Copolymers (Closed-Cell Foam) | AS1 9.1.10.7 |
| Amend 5 Aug 2011 | ASTM D2240: 2005 Standard Test Method for Rubber Property | AS1 9.1.10.7 |
| Amend 5 Aug 2011 | ASTM D6134: 2007 Standard Specification for Vulcanised Rubber Sheets Used in Waterproofing Systems | AS1 4.3.9, 8.5.4 |
| Amend 5 Aug 2011 | ASTM E96: 2005 Standard Test Methods for Water Vapour Transmission of Materials | AS1 Table 23 |
| | ASTM E104: 2002 Standard Practice for Maintaining Constant Relative Humidity by Means of Aqueous Solutions | AS1 10.3.2 |
| Amend 5 Aug 2011 | ASTM E2098: 2000 Standard Test Method for Determining Tensile Breaking Strength of Glass Fibre Reinforcing Mesh for Use in Class PB Exterior Insulation and Finish Systems (EIFS), after Exposure to a Sodium Hydroxide Solution | AS1 9.9.3.2 |
| | ASTM E2134: 2001 Standard Test Method for Evaluating the Tensile-Adhesion Performance of an Exterior Insulation and Finish System (EIFS) | AS1 9.9.6 |
| Amend 5 Aug 2011 | ASTM G154: 2006 Standard Practice for Operating Fluorescent Light Apparatus for UV Exposure of Nonmetallic Materials | AS1 9.1.10.7 |
| Amend 5 Aug 2011 | ASTM G155: 2005 Standard Practice for Operating Xenon Arc Light Apparatus for UV Exposure of Nonmetallic Materials | AS1 9.1.10.7 |
| Building Research Association of New Zealand | | |
| Amend 5 Aug 2011 | BRANZ Bulletin 330: 1995 Thin flooring materials – 2 Preparation and laying. Appendix 1 | AS1 10.3.2 |
| Amend 2 Jul 2005 | BRANZ EM 4: 2005 Evaluation method for jointing systems for flush finished fibre cement sheet | AS1 9.7.4, 9.7.10.2 |
| Amend 2 Jul 2005 | BRANZ EM 5: 2005 Evaluation method for adhesives and seam tapes for butyl and EPDM rubber membranes | AS1 8.5.4 |
| Amend 5 Aug 2011 | BRANZ EM 6: 2010 Evaluation method for window and door support mechanisms or bars | AS1 9.1.10.5 |
| | BRANZ Bulletin 411: 2001 Recommended timber cladding profiles | AS1 9.4.1.1 |

| | | Where quoted |
|---------------------|---|--|
| | SCION | |
| Amend 5 Aug 2011 | Measurement of moisture content of wood | AS1 10.3.1 |
| | Other Organisations | |
| Amend 5 Aug 2011 | Federal Specification Elastomeric type, cold applied single component Standard TT-S-00230C for caulking, sealing, and glazing in buildings, building areas (plazas, decks, pavements), and other structures | AS1 4.5.2, 8.4.11.1, 9.1.6, 9.1.9.3, 9.2.8.2, 9.5.3.2, 9.6.7, 9.9.3, 9.9.8 |
| | EIMA 101.91: 1992 EIFS Industry Members Association. Standard Guide for resin of resin coated glass fiber mesh in exterior insulation and finish systems (EIFS), Class PB. | AS1 9.9.3.2 |
| | ICBO Evaluation Acceptance criteria for flashing materials Services Inc AC148 | AS1 4.3.11, 9.1.5, 9.9.4.4 |
| Amend 5 Aug 2011 | ISO 9223: 1992 Corrosion of metals and alloys; corrosivity of atmospheres; classification | AS1 4.2.1, 8.3.4.1, 8.4.3.1, 9.6.3.1, Table 20 |
| Amend 5 Aug 2011 | ISO 11600: 2002 Building Construction – Jointing products Classification and requirements for sealants 9.5.3.2, 9.6.7, 9.9.3, | AS1 4.5.2, 8.4.11.1, 9.1.6, 9.1.9.3, 9.2.8.2, 9.5.3.2, 9.6.7, 9.9.3, 9.9.8 |
| | ISO/TS 15510: 2003 Stainless steels – chemical composition | AS1 4.3.5 |
| Amend 5 Aug 2011 | New Zealand Metal Roof and Wall Cladding Code of Practice: 2008 New Zealand Metal Roofing Manufacturers Inc. | AS1 4.3, 4.5.1, 4.5.2, 8.1.6.2, 8.3.1, 8.4.1, 8.4.12, 8.4.14, 8.4.15, 8.4.16.2, 8.4.17 |
| | Cement & Concrete Association of New Zealand | |
| Amend 5 Aug 2011 | CCANZ – CP01 Code of Practice for weathertight concrete and concrete masonry construction | AS3 1.0 |

ARCHIVED

Definitions

Amend 2
Jul 2005

This is an abbreviated list of definitions for words or terms particularly relevant to this Compliance Document. The definitions for any other italicised words may be found in the New Zealand Building Code Handbook.

Air seal A continuous seal fitted between a window or door reveal and the surrounding wall *framing* to prevent the flow of air into the interior of the *building*.

Anti-ponding board A board laid under the lowest row of concrete and clay roof tiles and supports the *roof underlay*.

The board is sloped to ensure moisture under the tiles is directed to the exterior of the roof.

Apron flashing A near flat or sloping *flashing* with a vertical upstand, used at junctions between roofs and walls.

Attached garage A garage that shares a common *wall* or *walls* with a habitable *building*, and is enclosed by *roof* and *wall claddings* that are continuous with the habitable part of the *building*.

Amend 5
Aug 2011

Base metal thickness (BMT) The thickness of the bare or base metal before any subsequent coating, such as galvanizing.

Bird's beak A double fold applied to the edge of a horizontal metal *flashing* to stiffen the edge and to assist in deflecting moisture away from the *cladding system* below. Refer also **Kick-out** and **Drip edge**.

COMMENT:

A *bird's beak* is used at the bottom of a *capping* to deflect water away from the *enclosed balustrade cladding*.

Amend 5
Aug 2011

Butt flashing A preformed wall *flashing*, used to flash windows and corners on horizontal profiled metal wall *cladding*.

A *butt flashing* is shaped to underflash the *cladding*, with the *cladding* butting against the exposed box portion of the *flashing*.

Cantilevered deck A *deck* where no support is provided at the outer extremities of the *deck*.

COMMENT:

Cantilevered decks are often constructed by extending *framing* members through the *cladding* beyond the *building* face. *Cantilevered decks* are sometimes known as balconies.

Amend 2
Jul 2005

Capping A *flashing* formed to cover the top of an *enclosed balustrade* or *parapet*. Also known as a coping.

Cavity batten A vertical packing member used to create a *drained cavity* as part of a *cladding system*.

Cavity wall A term used to describe a wall that incorporates a *drained cavity*.

Cavity spacer A short block used to provide intermittent support for fixings or pipe penetrations through a *drained cavity*, while not interrupting drainage within the cavity.

A *cavity spacer* is required to be set to a slight fall (5° minimum from horizontal) to allow drainage of any moisture from the top.

Cladding The exterior weather-resistant surface of a *building*.

COMMENT:

Includes any supporting substrate and, if applicable, surface treatment.

Cladding system The outside or exterior weather-resistant surface of a *building*; including *roof cladding* and *roof underlays*, *wall cladding* and *wall underlays*, and cavity components, rooflights, windows, doors and all penetrations, *flashings*, seals, joints and junctions.

Where required by this Acceptable Solution, the *cladding system* shall include a *drained cavity*.

Control joint A joint designed to prevent damage by accommodating movement. See also **Expansion joint**.

Damp-proof course (DPC) A strip of *durable vapour barrier* placed between *building elements* to prevent the passage of moisture from one element to another.

Amend 5
Aug 2011Amend 5
Aug 2011

Damp-proof membrane (DPM) A sheet material, coating or *vapour barrier*, having a low water vapour transmission, and used to minimise water and water vapour penetration into *buildings*. Usually applied against concrete in contact with the ground. (Also known as a concrete underlay.)

Amend 5
Aug 2011

Deck An open platform projecting from an exterior wall of a *building* and supported by *framing*. A *deck* may be over enclosed internal spaces, or may be open underneath. Refer also **Enclosed deck**. Also known as a balcony.

Direct fixed A term used to describe a wall *cladding* attached directly to the wall *framing*, without the use of a *drained cavity*.

Dormer or dormer window A framed structure that projects from a sloping roof, and has a window at its outer end.

Drained cavity A cavity space, immediately behind a wall *cladding*, that has vents at the base of the wall. Also known as a drained and vented cavity and referred to in this Acceptable Solution as a cavity or drained cavity.

Amend 2
Jul 2005

Amend 5
Aug 2011

A *drained cavity* assists drying by allowing water which occasionally penetrates the wall *cladding system* to drain to the exterior of the *building*, and any remaining moisture to dry by evaporation. Where this Acceptable Solution requires a nominal 20 mm *drained cavity*, the depth shall be between limits of 18 mm and 25 mm.

For definition of masonry veneer cavity refer to SNZ HB 4236.

Amend 2
Jul 2005

Drip edge Fold(s) applied to the edge of a horizontal metal *flashing* to deflect moisture away from the *cladding system* below. Refer also **Bird's beak** and **Kick-out**.

Amend 5
Aug 2011

Dwang A short (usually horizontal) member fixed between *framing* timbers. Also known as nogging.

Eaves That part of the roof *construction*, including *cladding*, fascia and eaves gutter (spouting), that extends beyond the exterior face of the wall.

Amend 5
Aug 2011

EIFS (Exterior Insulation and Finish System). A polystyrene sheet-based *cladding system* that uses mesh reinforced polymer-modified cement-based or polymer-based plaster base coats and a protective top coating.

Electrolytic corrosion Galvanic corrosion commonly resulting from the contact of two dissimilar metals when an electrolyte such as water is present.

Enclosed balustrade A timber-framed barrier with *cladding* across all exposed faces. Refer also **Parapet**.

Amend 5
Aug 2011

Enclosed deck A *deck*, whether over an interior or exterior space, that has an impermeable upper surface and is closed on the underside. May also be known as a balcony.

Envelope complexity The categorisation of the complexity of the total *building* envelope into one of four classes, depending on the particular features of the *building* as specified in this Acceptable Solution.

EPDM (Ethylene Propylene Diene Monomer) A thermosetting synthetic rubber used as a resilient part of a sealing washer, or as a roof *membrane*.

Expansion joint A joint designed to prevent damage by accommodating movement. See also **Control joint**.

External wall Any vertical exterior face of a *building* consisting of *primary* and/or *secondary elements* intended to provide protection against the outdoor environment.

Amend 5
Aug 2011

Finished ground level (FGL) The level of the ground against any part of a *building* after all backfilling and/or landscaping and/or surface paving has been completed.

Amend 5
Aug 2011

Flashing A component, formed from a rigid or flexible *waterproof* material, that drains or deflects water back outside the *cladding system*.

Flexible flashing tape A flexible self-adhesive *waterproof* tape. Usually used as an accessory for *wall underlays*, to seal corners and intersections.

Amends
2 and 5

Flush-finished The description of a *cladding* and joints system which relies on a protective coating applied to the face of the *cladding* to prevent the penetration of water.

Framing Timber members to which *lining*, *cladding*, flooring, or decking is attached; or which are depended upon for supporting the structure, or for resisting forces applied to it.

Hem A flat fold, not completely closed, applied to the edge of a metal *flashing*.

Hidden gutter A gutter located within the boundaries of the roof *framing*. *Hidden gutters* may also be known as secret gutters or internal gutters. See also **Valley gutters**.

COMMENT:

Hidden gutters are distinct from gutters or spouting that are externally located beyond the bounds of the roof and wall *framing*.

Hook An open fold applied to the edge of a metal *flashing*.

COMMENT:

A *hook* is distinct from a *hem*, as it is open at an acute angle rather than flattened.

Kick-out A single fold applied to the edge of a horizontal metal *flashing* to deflect moisture away from the *cladding system* below. Refer also **Bird's beak**.

COMMENT:

A **kick-out** is used at the bottom of a *capping* or other *flashing* to deflect water away from the *cladding* below.

Lining The rigid sheet covering for a wall, ceiling or other interior surface.

Masonry tiles Clay or concrete tile roof *cladding*.

Masonry veneer Clay or concrete block veneer *cladding*.

Membrane A non-metallic material, usually synthetic, used as a fully supported roof *cladding*, *deck* surface or, in conjunction with other *claddings*, as gutters or *flashings*.

Amend 5
Aug 2011

NZBC New Zealand Building Code.

Parallel flashing A roof *flashing* that runs along the roof slope, parallel to the roof *cladding* profile. Also known as a longitudinal *flashing*.

Parapet A timber-framed wall that extends above the level of the roof *cladding*. Refer also **Enclosed balustrade**.

Amend 5
Aug 2011

Purlin A horizontal member laid to span across *rafters* or trusses, and to which the roof *cladding* is attached.

Rafter A *framing* timber, normally parallel to the slope of the roof, providing support for sarking, *purlins* or roof *cladding*.

Risk matrix A table that allows the calculation of a *risk score* by the allocation and summing of scores for a range of design and location factors applying to a specific *building* design.

Risk score An aggregated numerical score for a proposed *building* as defined by this Acceptable Solution. The *risk score* is determined by completion of the *risk matrix*.

Roof That part of a *building* having its upper surface exposed to the outside and at an angle of 60° or less to the horizontal.

Amend 5
Aug 2011

Roof underlay An absorbent permeable *building* paper that absorbs or collects condensation or water in association with *roof cladding* performance.

Amend 5
Aug 2011

Saddle flashing A *flashing* used to weatherproof the junction between a horizontal and vertical surface.

Scupper An opening in a *parapet* or *enclosed balustrade* to allow water to drain into a rainwater head.

Sill support bar A bar or mechanism complying with EM6, E2/VM1 tests, and Clause B2 of the *Building Code*, and used to support the weight of aluminium window and door joinery that is installed over drained cavities.

Amend 5
Aug 2011

Soft edge A compatible soft edging seamed onto *flashings* to provide closure to profiled *cladding*.

Specific design Design and detailing for compliance with the *Building Code*, of a proposed part or parts of a *building* which are not shown in this Acceptable Solution.

Amend 5
Aug 2011

Amend 2
Jul 2005

Stanchion A connecting device, fixed into the structure of a building, that provides support for handrails, aerials and similar structures.

Stopend A turn-up at the upper edge of profiled metal *cladding*, or at the end of gutters and some types of *flashings*.

COMMENT:

A *stopend* assists the control of moisture by ensuring any moisture reaching the edge of the roofing is deflected from further entry.

Storey That portion of a *building* included between the upper surface of any floor and the upper surface of the floor immediately above, except the top *storey* shall be that portion of a *building* included between the upper surface of the topmost floor and the ceiling or roof above.

Stucco A wall *cladding system* formed from reinforced solid plaster over a rigid or non-rigid backing.

Stud A vertical *framing* timber.

Transverse flashing A roof *flashing* that runs across the roof slope, at right angles to the roof *cladding* profile.

Trapezoidal A type of profiled metal *cladding* with symmetrical or asymmetrical crests, with troughs between the crests.

Trough profile A type of profiled metal *cladding* comprising vertical ribs with flat, or lightly profiled pans between the ribs. Also known as ribbed, secret fixed or tray profile.

Underlay The material used behind a *roof* or *wall cladding*. Refer **Wall underlay** and **Roof underlay**.

Valley gutter A gutter running down the valley formed by the intersection of two pitched roof surfaces.

Wall refer **External wall**.

Wall underlay A building paper, synthetic material or rigid sheathing used as part of the *wall cladding system* to assist the control of moisture by ensuring moisture which occasionally penetrates the *wall cladding* is directed back to the exterior of the *building*.

Waterproof and **waterproofing** The complete and total resistance of a *building element* to the ingress of any moisture.

Weathertightness and **weathertight** Terms used to describe the resistance of a *building* to the weather.

Weathertightness is a state where water is prevented from entering and accumulating behind the *cladding* in amounts that can cause undue dampness or damage to the *building elements*.

COMMENT:

The term *weathertightness* is not necessarily the same as *waterproof*.

However, a *weathertight building*, even under severe weather conditions, is expected to limit moisture ingress to inconsequential amounts, insufficient to cause undue dampness inside *buildings* and damage to *building elements*. Moisture that may occasionally enter is able to harmlessly escape or evaporate.

Wetwall The exterior *cladding* on a wall with a *drained cavity*.

Wind zone Categorisation of wind force experienced on a particular site as determined in NZS 3604, Section 5.

COMMENT:

Maximum ultimate limit state speeds are:

| | | |
|-----------------------------|---|-----------------------|
| Low <i>wind zone</i> | = | wind speed of 32 m/s |
| Medium <i>wind zone</i> | = | wind speed of 37 m/s |
| High <i>wind zone</i> | = | wind speed of 44 m/s |
| Very high <i>wind zone</i> | = | wind speed of 50 m/s |
| Extra high <i>wind zone</i> | = | wind speed of 55 m/s. |

Specific design is required for wind speeds greater than 55 m/s.

Amend 5
Aug 2011
Amend 2
Jul 2005

Amend 5
Aug 2011

Amend 5
Aug 2011

Amend 5
Aug 2011

Verification Method E2/VM1

1.0 Cladding systems of buildings, including junctions with windows, doors and other penetrations

1.1 General

This Verification Method is for determining compliance with NZBC E2.3.2 of *cladding systems* and associated window and door junctions only, for *buildings* of importance Levels 1 or 2 as described in Table 1.1(a) of NZS 3604.

The tests in this Verification Method shall be undertaken in a test facility with IANZ or equivalent accreditation for testing the *weathertightness* of *claddings* to the procedures of AS/NZS 4284, and as used to establish the performance criteria detailed in Paragraph 1.4 Test Procedures.

COMMENT:

The *weathertightness* testing of AS/NZS 4284 is modified in this Verification Method for generic domestic-oriented *cladding* because the Standard was developed primarily for testing specific, non-absorptive facades and curtain wall systems on high-rise commercial *buildings*.

1.2 Scope

1.2.1 The scope of this Verification Method shall be restricted to *buildings* that:

- a) are in accordance with the scope of Paragraph 1.0 of E2/AS1, and within the *wind zones* covered by Section 5 of NZS 3604, and
- b) have *claddings* that include a drained and vented cavity of nominal 20 mm minimum depth with minimum ventilation opening of 1000 mm²/m at the foot, including any *claddings* that require a rigid *wall underlay* in accordance with Paragraph 9.1.7.2 of E2/AS1, and
- c) include window and door units that are manufactured to comply with the relevant requirements of NZS 4211, and

- d) may include *buildings* based on (a), (b) and (c) above, but with specific engineering design frame elements of at least equivalent stiffness to the *framing* provisions defined in NZS 3604.

1.2.2 This Verification Method may also be used for individual *buildings* that comply with (a) to (d) above, and that are designed for a specific wind pressure up to a maximum ultimate limit state (ULS) of 2500 Pa.

COMMENT:

While the test specimens used for this Verification Method may include window and door units, it is only the junctions of these elements with other *cladding* elements that are assessed in the test.

1.3 Specimen details

The minimum size of the wall *cladding* specimen to be tested shall be 2.4 m x 2.4 m.

Any *cladding system* within an Extra High *wind zone* or subject to a specific design wind pressure up to ULS 2500 Pa that relies on this Verification Method shall have a rigid *underlay* installed in accordance with Paragraph 9.1.7 of E2/AS1. In either of these two circumstances, a rigid *underlay* is not necessary for the verification tests as a flexible *wall underlay* may suffice – unless the *cladding* to be tested specifically includes a rigid air barrier as part of the *specified system*.

If the *cladding system* is never to be used with *building elements* penetrating the exterior surface *walls*, then the specimen shall include the details from Class 1. In all other cases, specimens with the details of Class 2 shall be tested, where the classes are described below:

Class 1: *Cladding systems* where only vertical joints are required, and having no penetrations through the *cladding*. Testing shall include vertical joints, internal and external corners of the external *wall* junctions, and footer and header termination systems.

Class 2: All other *cladding systems* to be used within the scope of this document.

Testing is to include representative samples of penetrating *building elements* or joints, and including vertical and horizontal *control joints*, internal and external *wall junctions*, windows and/or doors, electrical meter boxes, balcony drainage and *parapet flashings*, and footer and header termination systems, plus any other relevant details.

To allow the observation of any water penetration, a proportion of the internal wall *lining* shall be made using transparent material of sufficient structural capability and similar airtightness to resist the applied wind pressures. Adjacent to critical elements where visual access is required, the *wall underlay* shall be cut through and fastened back onto the *framing*, with the transparent internal *lining* fully sealing the internal perimeter of the observation opening. It is required that at least 2% of the area of the *wall underlay* (or equivalent) be so removed. A 15 mm diameter round hole shall be formed in the internal *lining* below the window to simulate the effect of power points, light switches and other air leakage through the internal *lining*.

1.4 Test procedure

The Verification Method shall consist of the extended water penetration test methodologies of AS/NZS 4284, following a preconditioning pressure loading exposure.

1.4.1 Preconditioning

Apply a preconditioning loading to the external face of the test sample for a period of 1 minute of positive pressure, followed by a period of 1 minute of negative pressure (suction). The loading shall be 1515 Pa.

COMMENT:

As the ventilated cavity is subjected to the same applied pressure, it is necessary that the material serving as the *air seal* is able to sustain the same applied loading.

Where the test wall is utilising a permeable *wall underlay* or *membrane*, the internal wall *lining* will be required to sustain the serviceability limit state (SLS) wind pressures.

1.4.2 Series 1 Static Pressure Water Penetration

The water penetration test by static pressure shall be conducted in accordance with Clause 8.5 of AS/NZS 4284 and at the maximum test pressure of 455 Pa.

1.4.3 Series 1 Cyclic Pressure Water Penetration

The water penetration test by cyclic pressure shall be conducted in accordance with Clause 8.6 of AS/NZS 4284 and to the cyclic pressure of 455 – 910 Pa at the prescribed Stage 3, with the Stage 1 and Stage 2 tests deleted.

1.4.4 Series 2 'Water Management Testing'

Paragraphs 1.4.2 and 1.4.3 shall be repeated, following the formation of 6 mm diameter holes through the *wetwall* as allowed in AS/NZS 4284 Clause 9.9 in at least 4 places, as noted below:

- a) Through the window/wall joint at 3/4 height of both window/door jambs,
- b) Immediately above the head *flashing*,
- c) Through the external sealing of the horizontal and vertical joints, and
- d) Above any other *wetwall* penetration detail.

The introduction of defects is intended to simulate the failure of the primary weather-defence/sealing. It must only penetrate to the plane of the back of the *wetwall* so the water management of the cavity can be assessed.

1.4.4.1 Immediately upon the conclusion of the Water Management Tests (within 30 minutes) (Paragraph 1.4.4), the layers behind the *wetwall* that support air pressure (including sealing in the window trim cavity) shall be removed, and any evidence of non-compliance (as defined in Paragraph 1.4.5.3) noted.

Amend 5
Aug 2011

1.4.5 Series 3 'Wetwall Test'

1.4.5.1 Repeat Paragraph 1.4.3 with an air pressure of 50 Pa, applied across the *wetwall* only, for 15 minutes.

1.4.5.2 Non-compliance shall be the presence of water (as defined in Paragraph 1.4.5.3) after carrying out the tests in Paragraphs 1.4.2 and 1.4.3, and the subsequent 'water management' tests (or evidence of any water) on the removed surfaces of the cavity.

1.4.5.3 Water which is able to penetrate to the back of the *wetwall* through introduced defects and joints shall be controlled. It may contact battens and other cavity surfaces, but no water shall be transferred to the plane of the *wall underlay*, cavity air sealing or structural *framing* due to a design or systemic failure. Water that may arrive on the *underlay* due to an 'isolated blemish' may be disregarded. No water may drip through an air-space within the cavity where it is possible for water to impact on a surface in the cavity and splash onto the *wall underlay*. However, the spattering of water into the cavity through the introduced defects shall be ignored.

During the *Wetwall Test*, water is allowed to spatter up from the footer *flashing*, provided it is not held above any cavity obstruction.

1.5 Transition period for existing verification certificates as at 31 August 2011

1.5.1 E2/VM1, included in E2 Compliance Document Amendment 5, is effective from 1 August 2011.

1.5.2 E2/VM1, included in E2 Compliance Document Amendment 4, remains effective up to and including 30 June 2013, provided that any testing under E2/VM1 from 1 August 2011 must be under E2 Compliance Document Amendment 5.

1.5.3 From 1 July 2013, only E2/VM1 included in E2 Compliance Document Amendment 5 applies and supersedes all previous versions of the document.

1.6 Pro-forma for test details

The pro forma attached as Appendix 1 to this Verification Method may be used to provide specifiers with a summary of test details and results.

2.0 Pitched roofing systems over a ventilated roof space of 15° pitch or more

2.1 AS 4046 Part 9 provides a Verification Method for determining compliance with NZBC E2.3.2 of any tiled roofing system of 15° pitch or more above a *roof space* (i.e. not a *skillion roof*). Compliance is based on comparison of performance with a control roofing system described in the Standard. Compliance is achieved where the water penetration is less than, or equal to, the control sample. This test is also a Verification Method for other ventilated roofing systems or skylights with a pitch of 15° or more above a *roof space*.

3.0 Skillion roofs and commercial and industrial roofing

3.1 No specific method has been adopted for verifying compliance of *skillion roofs* or commercial or industrial roofing with NZBC E2.3.2.

Appendix 1: Pro forma

Test results shall be expressed in the following tabulated format within the usual Test Report of the particular test laboratory.

Amend 5
Aug 2011

Series 1: Static Water Penetration

Test pressure 455 Pa
Duration 15 minutes

Amend 5
Aug 2011

Series 1: Cyclic Water Penetration

Test pressure 455–910 Pa
Duration 5 minutes

Amend 5
Aug 2011

**Series 2: Water Management Tests
Static Water Penetration**

Test pressure 455 Pa
Duration 15 minutes

Amend 5
Aug 2011

**Series 2: Water Management Tests
Cyclic Water Penetration**

Test pressure 455–910 Pa
Duration 5 minutes

Amend 5
Aug 2011

Series 3: Wetwall Test Static Water Penetration

Test pressure 50 Pa
Duration 15 minutes

Additional water penetration requirements:

[Empty rounded rectangular box for additional water penetration requirements]

Comments:

[Empty rounded rectangular box for comments]

Acceptable Solution E2/AS1

Amend 5
Aug 2011**1.0 Scope**

This Acceptable Solution covers the *weathertightness* of the *building* envelope. Notes shown under 'COMMENT', occurring throughout this document are for guidance purposes only and do not form part of this Acceptable Solution.

Amend 2
Jul 2005**1.1 Construction included**

The scope of this Acceptable Solution is limited to the materials, products and processes contained herein, for *buildings* within the scope of NZS 3604, and:

Amend 2
Jul 2005

- a) Up to 3 *storeys* with a height measured from lowest ground level adjacent to the *building* to the highest point of the *roof* (except for chimneys, aerials and the like) of 10 m or less, and
- b) With floor plan area limited only by seismic and structural *control joints*, and
- c) *External walls* that are vertical, and *roofs* that are 60° or less above the horizontal.

Amend 5
Aug 2011

Where *buildings* are based on NZS 3604, but require specific engineering design input, the *framing* shall be of at least equivalent stiffness to the *framing* provisions of NZS 3604.

Amend 5
Aug 2011**COMMENT:**

The floor plan limitations of NZS 3604 may be exceeded up to the point that *specific design* is required to accommodate seismic or wind movement. Beyond that point, *specific design* is required to demonstrate compliance with Clause E2 of the *Building Code*.

Amend 5
Aug 2011

Claddings also required to perform as bracing must comply with NZS 3604. Where a *drained cavity* is used, specific testing can be used to demonstrate that a *cladding on cavity battens* can provide the required bracing resistance.

Amend 5
Aug 2011**1.1.1 Attached garages**

Attached garages that are integral with the *weathertightness* envelope of the *building* are included within the scope of this Acceptable Solution. Refer to Paragraph 9.1.3.4.

Amend 5
Aug 2011**1.2 Construction excluded****1.2.1 Outbuildings**

Outbuildings, such as stand-alone garages and other structures that are unlined, are outside the scope of this Acceptable Solution.

Amend 5
Aug 2011**COMMENT:**

Details contained in this Acceptable Solution can be used for outbuildings and unlined structures, but the requirements may be in excess of the minimum required by the *Building Code*.

Amend 5
Aug 2011

This is particularly the case in regard to unlined and uninsulated *buildings*, where a *drained cavity* is unlikely to be necessary.

However, care must be taken, as some *weathertight* details depend on the presence of an internal *lining* to provide pressure equalisation behind the *cladding*.

Amend 2
Jul 2005**1.2.2 Spread of flame**

Buildings with *drained cavities* and spread-of-flame requirements, as specified in NZBC C Clauses, are outside the scope of this Acceptable Solution. Cavities in such circumstances must be specifically designed for both *weathertightness* and spread of flame.

Amend 5
Aug 2011**COMMENT:**

Options could include the provision of a *fire rated* wall behind the battens, or breaking the cavity at each floor and providing a cavity *flashing* and *fire stop* at each level.

Amend 5
Aug 2011**1.2.3 Acoustics**

Buildings with *drained cavities* and acoustic requirements, as specified in NZBC Clause G6, are outside the scope of this Acceptable Solution.

Amend 2
Jul 2005**COMMENT:**

Cavities in such circumstances must be specifically designed for both *weathertightness* and acoustic performance.

1.3 Provisions for snow

Specific design for preventing the ingress of snow melt water is required when the open ground snow load S_g , as defined in NZS 3604, exceeds 1.0 kPa, and the roof is *constructed* in a way that is likely to cause a build-up of snow.

Amend 2
Jul 2005Amend 5
Aug 2011

COMMENT:

Hidden gutters, parapets and skylights are examples of features within a *roof* design that are likely to cause a build-up of snow.

However, some additional work, such as extra fixings that penetrate *flashings*, can lead to details that need to be considered in terms of *specific design*.

Amend 2
Jul 2005

Additional or alternative details may be required that need supporting documentation or testing to demonstrate compliance in regard to *weathertightness*.

Amend 2
Jul 2005

1.4 Specific design

Buildings, components or junction details not included or shown in this Acceptable Solution require *specific design*.

Amend 5
Aug 2011

Amend 2
Jul 2005

Amend 5
Aug 2011

1.5 Qualifications

Amend 2
Jul 2005

COMMENT:

An understanding of the proper methods of design and installation and the importance of the correct *construction* sequence is essential if an NZBC compliant *building* is to be achieved. Adequate training by those designing and applying particular products and *claddings* is therefore highly recommended.

The design, installation and alteration of *claddings* will be 'restricted work' under the licensed building practitioner scheme, due to take effect in 2012. Until then, the use of licensed designers, builders and installers is optional. It is important that product suppliers, manufacturers and NZ agents (for imported products) ensure those handling and applying their products are adequately trained to do so, and that site managers oversee the correct integration of adjoining *building elements* to achieve a complete weathering system.

Amend 5
Aug 2011

Amend 5
Aug 2011

Amend 5
Aug 2011

Amend 2
Jul 2005

2.2 Materials

Materials used to *construct* the *building* envelope shall be:

- a) In accordance with the *durability* requirements of NZBC B2,
- b) Suitable for their end-use, location and environment as shown in Table 20, and
- c) Compatible with adjoining materials as shown in Table 21 and Table 22.

2.3 Systems versus materials

All *building* products shall be considered as part of a system, even if the components of that system are provided from different sources. Materials used to *construct* the *building* envelope shall be designed as a complete *cladding system* rather than as separate items.

Amend 5
Aug 2011

COMMENT:

It is important that the compatibility and *durability* of the combination of materials is able to be demonstrated for any given application.

Amend 5
Aug 2011

2.0 General

2.1 Weathertightness

Cladding systems shall meet the requirements of NZBC E2.2 to E2.3.7, and the provisions of this Acceptable Solution are acceptable means of achieving this.

COMMENT:

Most manufacturers provide technical literature for their *cladding* materials and systems that include recommendations for design and installation.

Manufacturers' recommendations may include information additional to that shown in this Acceptable Solution.

2.4 Cladding finish colours

Finish colours for *flush-finished* fibre cement sheet and *EIFS* shall have a reflectivity of 40% or more when measured in accordance with ASTM C1549.

Amend 5
Aug 2011

COMMENT:

Dark colours cause *claddings* to reach higher temperatures, which results in more thermal expansion and a greater risk of cracking of joints in monolithic *wall claddings*. Risks of cracking are also associated with dark colours on painted timber *wall claddings* and trim. Expansion of metal roofing and *flashings* are affected by dark colours.

Colour cards from some coating manufacturers may include reflectance values.

Amend 5
Aug 2011

Amend 5
Aug 2011

Amend 5
Aug 2011

2.5 Maintenance – general

Maintenance shall be carried out as necessary to achieve the required *durability* of materials, components and junctions.

The extent and nature of necessary maintenance is dependent on the:

- Type of *cladding* or components used,
- Position of *cladding* or components on the *building*,
- Geographical location of the *building*, and
- Specific site conditions.

COMMENT:

A deterioration in the appearance of the surface of a *cladding* does not necessarily relate to a deterioration in the *weathertightness* of the *cladding*.

Amend 5
Aug 2011

2.5.1 Regular maintenance

Regular maintenance of a *building* will include:

- Washing exterior surfaces,
- Inspecting surfaces and junctions, and repairing or replacing items when necessary, in order to preserve the *weathertightness* of the *building*.
- Maintaining clearances between *cladding* and external ground or paving as per Paragraph 9.1.3.
- Maintaining minimum 35 mm clearances between *roofing* and *membrane* decking, and *wall cladding* above
- Maintaining finish coatings especially for *stucco*, *EIFS* and fibre cement *claddings*.

Amend 5
Aug 2011**COMMENT:**

Washing by rain removes most accumulated atmospheric contaminants, but sheltered areas, such as walls directly below *eaves*, are protected from the direct effects of rain and require regular manual washing.

Some heavily textured surfaces will not be as effectively washed by rain as smoother surfaces, so will require more regular manual washing.

However, it is important that high pressure water is not directed at sensitive junctions such as window surrounds and other *flashings*. Great care must be taken to avoid water being driven past anti-capillary gaps and *flashings* into the *wall* cavities.

3.0 Weathertightness Risk Factors

COMMENT:

Analysis of inspection reports from leaking *buildings* shows that a high incidence of leaks is associated with junctions within, and penetrations through, the *building* envelope. It also shows serious problems are more commonly associated with *claddings* that have limited capacity to drain and dry out any water that gets behind them, when a leak occurs.

This Acceptable Solution addresses these problems in two ways:

- By providing details for common junctions and penetrations of the *building* envelope, and
- By classifying *buildings* within the scope of this document into risk categories, and requiring different *cladding* solutions depending on the *risk score*.

Using the risk assessment, risk factors can be identified and changes may be made to a design to lower the *risk score*.

Amend 5
Aug 2011

3.1 Establishing the risk

A risk assessment of the proposed design shall be carried out using a *building* envelope *risk matrix*. This allows the risks related to various features to be aggregated, resulting in a *risk score* for the design.

Figure 1 shows the process that shall be followed in order to assess the risk.

3.1.1 Definitions of risk

Table 1 sets out the definitions of risk levels relating to the location and design features of the *building*.

3.1.2 The risk score

Table 2 sets out the *risk matrix* that shall be used to define the *risk score* for a *building* within the scope of this Acceptable Solution.

A *risk score* is calculated for each external face of the *building*. *Claddings* are then selected from Table 3 according to the *risk scores*, or the highest *risk score* may be used for all *walls*.

Amend 5
Aug 2011

Amend 5
Aug 2011

Amend 2
Jul 2005

Amend 5
Aug 2011

3.3 Wall claddings

The following wall *cladding systems* are covered in this Acceptable Solution:

- a) *Masonry veneer* Paragraph 9.2
- b) *Stucco* Paragraph 9.3
- c) Timber weatherboards Paragraph 9.4
- d) Fibre cement weatherboards Paragraph 9.5
- e) Profiled metal wall claddings Paragraph 9.6
- f) Fibre cement sheet Paragraph 9.7
- g) Plywood sheet Paragraph 9.8
- h) *EIFS* Paragraph 9.9.

Amend 2
Jul 2005

Other wall *claddings* are outside the scope of this Acceptable Solution.

Amend 5
Aug 2011

Figure 1: How to assess risk
Paragraph 3.1

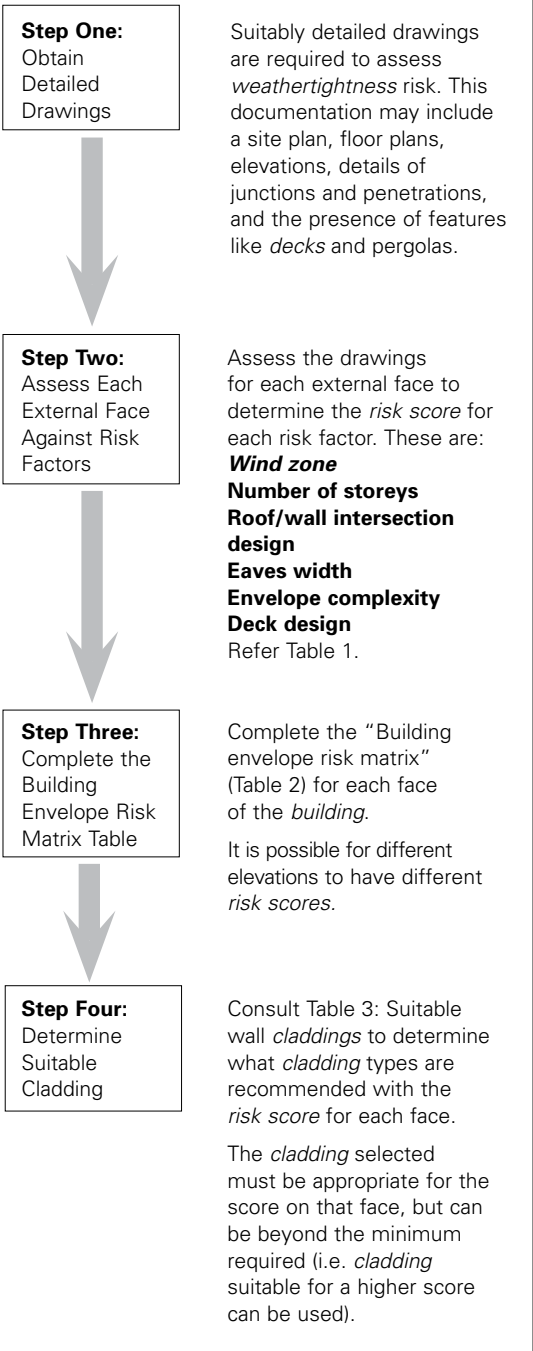

| Table 1: Definitions of risk levels Paragraph 3.1.1, Figure 1 | | | |
|--|-----------------|------------------------|---|
| Risk Factor | Score(5) | Risk severity | Comments |
| A: Wind zone | 0 | Low risk | Low <i>wind zone</i> as described by NZS 3604 |
| | 0 | Medium risk | Medium <i>wind zone</i> as described by NZS 3604 |
| | 1 | High risk | High <i>wind zone</i> as described by NZS 3604 |
| | 2 | Very high risk | Very High <i>wind zone</i> as described by NZS 3604 |
| | 2 | Extra high risk | Extra High <i>wind zone</i> as described in NZS 3604 (4) |
| B: Number of storeys | 0 | Low risk | One <i>storey</i> |
| | 1 | Medium risk | Two <i>storeys</i> in part |
| | 2 | High risk | Two <i>storeys</i> |
| | 4 | Very high risk | More than two <i>storeys</i> |
| C: Roof/wall junctions | 0 | Low risk | Roof-to-wall intersection fully protected (e.g. hip and gable roof with <i>eaves</i>) |
| | 1 | Medium risk | Roof-to-wall intersection partly exposed (e.g. hip and gable roof with no <i>eaves</i>) |
| | 3 | High risk | Roof-to-wall intersection fully exposed (e.g. <i>parapets</i> , <i>enclosed balustrades</i> or <i>eaves</i> at greater than 90° to vertical with soffit <i>lining</i>) |
| | 5 | Very high risk | Roof elements finishing within the boundaries formed by the exterior walls (e.g. lower ends of aprons, <i>chimneys</i> , <i>dormers</i> etc) |
| D: Eaves width (1)(2) | 0 | Low risk | Greater than 600 mm for single storey |
| | 1 | Medium risk | 451–600 mm for single storey, or over 600 mm for two storey |
| | 2 | High risk | 101–450 mm for single storey, or 451–600 mm for two storey, or greater than 600 mm above two storey |
| | 5 | Very high risk | 0–100 mm for single storey, or 0–450 mm for two storey, or less than 600 mm above two storey |
| E: Envelope complexity | 0 | Low risk | Simple rectangular, L, T or boomerang shape, with single <i>cladding</i> type |
| | 1 | Medium risk | Moderately complex, angular or curved shapes (e.g. Y or arrowhead) with no more than two <i>cladding</i> types |
| | 3 | High risk | Complex, angular or curved shapes (e.g. Y or arrowhead) with multiple <i>cladding</i> types |
| | 6 | Very high risk | As for High risk, but with junctions not covered in C or F of this table (e.g. box windows, pergolas, multi-storey re-entrant shapes etc) |
| F: Decks(3) | 0 | Low risk | None, timber slat <i>deck</i> or porch at ground floor level |
| | 2 | Medium risk | Fully covered in plan by <i>roof</i> , or timber slat <i>deck</i> attached at first or second floor level |
| | 4 | High risk | <i>Enclosed deck</i> exposed in plan or cantilevered at first floor level |
| | 6 | Very high risk | <i>Enclosed deck</i> exposed in plan or cantilevered at second floor level or above |
| NOTES: | | | |
| (1) <i>Eaves</i> width measured horizontally from external face of <i>wall cladding</i> to outer edge of overhang, including fascias and external gutters/spoutings. | | | |
| (2) Balustrades and <i>parapets</i> count as 0 mm <i>eaves</i> . | | | |
| (3) The term <i>deck</i> includes balconies, as described in the Definitions. | | | |
| (4) <i>Buildings</i> in Extra High <i>wind zones</i> require rigid <i>underlays</i> and <i>drained cavities</i> , refer to Table 3. | | | |
| (5) Refer also to Table 2. | | | |

Amend 2
Jul 2005

Amend 2
Jul 2005

Errata 2
Dec 2011

Amend 2
Jul 2005

Amend 2
Jul 2005

Amend 2
Jul 2005

Amend 2
Jul 2005

Errata 2
Dec 2011

Amend 5
Aug 2011

Amend 5
Aug 2011

Table 2: Building envelope risk scores
Paragraph 3.1.2, Figure 1

| Risk factor | Risk severity | | | | | | | | Subtotals for each risk factor |
|--|---------------|-------|--------|-------|------|-------|---------------|---|--------------------------------|
| | LOW | score | MEDIUM | score | HIGH | score | VERY HIGH (1) | score | |
| Wind zone (per NZS 3604)(1) | 0 | | 0 | | 1 | | 2 | | |
| Number of storeys | 0 | | 1 | | 2 | | 4 | | |
| Roof/wall intersection design | 0 | | 1 | | 3 | | 5 | | |
| Eaves width | 0 | | 1 | | 2 | | 5 | | |
| Envelope complexity | 0 | | 1 | | 3 | | 6 | | |
| Deck design | 0 | | 2 | | 4 | | 6 | | |
| (Enter the appropriate risk severity score for each risk factor in the score columns. Transfer these figures across to the right-hand column. Finally, add up the figures in the right-hand column to get the total risk score.) | | | | | | | | Total risk score for use in Table 3: | |

Amend 5
Aug 2011

Amend 5
Aug 2011

NOTE: (1) For *buildings* in Extra High *wind zones*, refer to Tables 1 and 3 for rigid *underlay* and *drained cavity* requirements.

| Table 3: Suitable wall claddings | | Paragraphs 3.1.2, 7.4, 9.1.1,9.1.7.2, 9.4.1.2, 9.4.1.3, 9.6, 9.6.1, Figure 1 | |
|--|---|--|--|
| Risk Score from Table 2 | Suitable wall claddings(1) | | |
| | Direct fixed to framing | Over nominal 20 mm drained cavity | |
| | | <i>Claddings on parapets, enclosed balustrades, and in Extra High wind zones shall be installed over drained cavities.(5)(6)</i> | |
| 0 – 6 | a) Timber weatherboards – all types b) Fibre cement weatherboards c) Vertical profiled metal – corrugated and symmetrical <i>trapezoidal</i> (3) d) Fibre cement sheet(4) (Jointed finish) e) Plywood sheet | a) <i>Masonry veneer</i> (2) b) <i>Stucco</i> c) Horizontal profiled metal(3) – corrugated and <i>trapezoidal</i> only d) Fibre cement – <i>flush-finished</i> e) <i>EIFS</i> | |
| 7 – 12 | a) Bevel-back timber weatherboards b) Vertical timber board and batten c) Vertical profiled metal – corrugated only(3)(6) | a) <i>Masonry veneer</i> (2) b) <i>Stucco</i> c) <i>Horizontal</i> profiled metal – corrugated and <i>trapezoidal</i> only d) Rusticated weatherboards e) Fibre cement weatherboard f) Fibre cement sheet – flush and jointed finish g) Plywood sheet h) <i>EIFS</i> | |
| 13 – 20 | a) Vertical profiled metal – corrugated only(3)(6) | a) <i>Masonry veneer</i> (2) b) <i>Stucco</i> c) Horizontal profiled metal – corrugated and <i>trapezoidal</i> only d) Rusticated weatherboards e) Fibre cement weatherboards f) Fibre cement sheet – flush and jointed finish g) Plywood sheet h) <i>EIFS</i> i) Bevel-back weatherboards | |
| Over 20 | a) Redesign the <i>building</i> to achieve a lower score, or b) <i>Specific design</i> <ul style="list-style-type: none"> – The design may need changing to reduce the risk – The <i>building consent authority</i> may require more comprehensive details and documentation providing evidence of <i>weathertightness</i> – The <i>building consent authority</i>, designer or <i>owner</i> may require more inspections – A third party audit of the design may be required. | | |
| NOTES: | | | |
| (1) The wall claddings in this table are limited to those covered in this Acceptable Solution. | | | |
| (2) Traditional <i>masonry veneer</i> as per SNZ HB 4236, with minimum 40 mm cavity. | | | |
| (3) Refer Figure 38 for profiles. | | | |
| (4) Except <i>stucco</i> over a fibre cement backing. | | | |
| (5) <i>Claddings</i> in Extra High <i>wind zones</i> require rigid <i>underlays</i> – refer to Paragraph 9.1.7.2 | | | |
| (6) Direct fix vertical corrugated steel is included as cavity construction. | | | |

Amend 5
Aug 2011

Amend 5
Aug 2011

Amend 2
Jul 2005
Amend 5
Aug 2011

Amend 5
Aug 2011

Amend 2
Jul 2005

Amend 2
Jul 2005

Amend 5
Aug 2011

Amend 2
Jul 2005

Amend 5
Aug 2011

Amend 2
Jul 2005

Amend 5
Aug 2011

Amend 2
Jul 2005

Amend 5
Aug 2011

3.4 Examples using the risk matrix

Paragraphs 3.4.1 to 3.4.3 provide examples that show a range of *building* styles. The completion of the *risk matrix* for each design is shown, together with the choice of wall *claddings* the *risk scores* indicate.

COMMENT:

The examples have been selected to show a range of design complexities, features and materials. Refer also to *Guide to the Risk Matrix*.

Amend 5
Aug 2011

3.4.1 Example 1

The first example illustrates the use of the *risk matrix* for a simple traditionally-styled *building*.

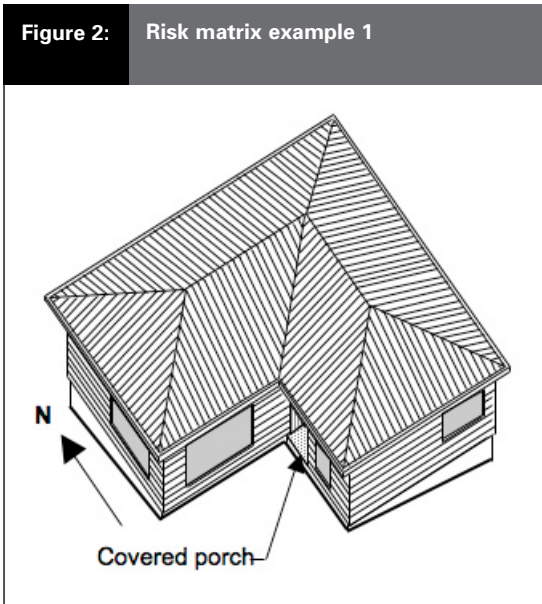

COMMENT:

The house in this example is a simple single *storey* L shape and is considered low risk in terms of *envelope complexity*.

The *eaves* are 500 mm wide, and the site is in a High *wind zone*.

The covered porch is at ground level and so is considered low risk.

For this example, the calculations have been done for the south elevation, and this face scores as very low risk. A similar *risk score* would result for all elevations of this *building*.

3.4.1.1 Cladding options

As all faces score low, *cladding* options from Table 3 are:

a) *Direct fixed claddings*:

- i) Timber weatherboards – all types shown
- ii) Fibre cement weatherboards
- iii) Vertical profiled metal – corrugated and symmetrical *trapezoidal* only
- iv) Fibre cement sheet – not *flush-finished*
- v) Plywood sheet

Amend 5
Aug 2011

Amend 5
Aug 2011

b) Wall *cladding* with a nominal 20 mm *drained cavity* (note: claddings in Extra High *wind zones* require rigid *underlays*):

- i) *Masonry veneer*
- ii) *Stucco*
- iii) Horizontal profiled metal – corrugated and *trapezoidal* only
- iv) Fibre cement – *flush-finished*
- v) *EIFS*.

Amend 2
Jul 2005
Amend 5
Aug 2011

Amend 2
Jul 2005

Amend 5
Aug 2011

Table 4: Risk matrix example 1 – south face

| Risk factor | Risk severity | | | | | | | | |
|-------------------------------|---------------|----------|--------|----------|------|----------|-----------|-------|--------------------------------|
| | LOW | SCORE | MEDIUM | SCORE | HIGH | SCORE | VERY HIGH | SCORE | Subtotals for each risk factor |
| Wind zone (per NZS 3604) | 0 | | 0 | | 1 | 1 | 2 | | 1 |
| Number of storeys | 0 | 0 | 1 | | 2 | | 4 | | 0 |
| Roof/wall intersection design | 0 | 0 | 1 | | 3 | | 5 | | 0 |
| Eaves width | 0 | | 1 | 1 | 2 | | 5 | | 1 |
| Envelope complexity | 0 | 0 | 1 | | 3 | | 6 | | 0 |
| Deck design | 0 | 0 | 2 | | 4 | | 6 | | 0 |
| Total risk score: | | | | | | | | | 2 |

3.4.2 Example 2

Amend 2
Jul 2005

The second example illustrates the use of the *risk matrix* for a moderately complex *building*.

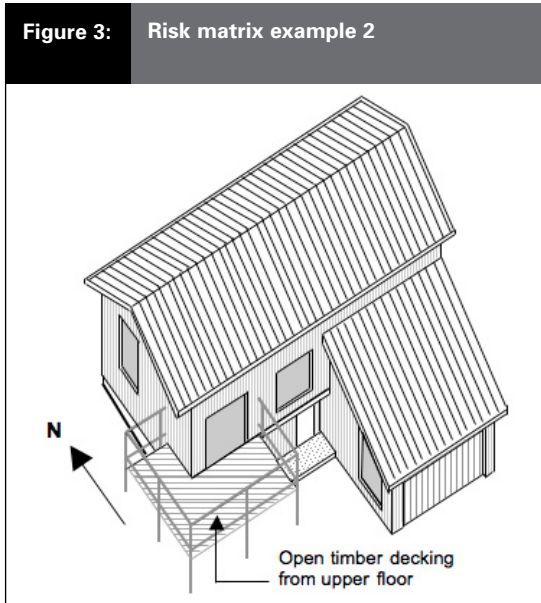

COMMENT:

Overall the house in this example is still a relatively simple design with a single *cladding* type. It would be considered to be medium risk in terms of *envelope complexity*.

The lean-to style room on the ground floor is quite simple but does introduce a roof-to-wall intersection which requires the correct *flashing* and particular care with the *kick-out* at the west end of the junction. This would make this factor very high risk.

The timber *deck*, itself low risk, connects to the house at the first floor level, and so is considered to be medium risk. Any leaks at the connection points have an opportunity to enter the *wall* below.

The *eaves* are less than 450 mm wide, and the site is in a High *wind zone*.

The calculations have been done for the south elevation. The other elevations of this *building* score lower because they are simpler.

The west elevation still has the *deck* connection and scores 7. *Cladding* options would be the same as for the south face.

The east elevation scores 6 and the north elevation scores 5, so these have more *cladding* options.

Amend 5
Aug 2011

Table 5: Risk matrix example 2 – south elevation

| Risk factor | Risk severity | | | | | | | | Subtotals for each risk factor |
|-------------------------------|---------------|-------|--------|----------|------|----------|-----------|-------|--------------------------------|
| | LOW | score | MEDIUM | score | HIGH | score | VERY HIGH | score | |
| Wind zone (per NZS 3604) | 0 | | 0 | | 1 | 1 | 2 | | 1 |
| Number of storeys | 0 | | 1 | 1 | 2 | | 4 | | 1 |
| Roof/wall intersection design | 0 | | 1 | | 3 | | 5 | 5 | 5 |
| Eaves width | 0 | | 1 | | 2 | 2 | 5 | | 2 |
| Envelope complexity | 0 | | 1 | 1 | 3 | | 6 | | 1 |
| Deck design | 0 | | 2 | 2 | 4 | | 6 | | 2 |
| Total risk score: | | | | | | | | | 12 |

Amend 5
Aug 2011

Amend 5
Aug 2011

3.4.2.1 Cladding options – south and west elevations

Cladding options from Table 3, are:

a) *Direct fixed claddings*:

- i) Bevel-back weatherboards
- ii) Vertical board and batten weatherboards
- iii) Vertical corrugated metal, and

Amend 2
Jul 2005

b) Wall *cladding* with a nominal 20 mm *drained cavity*:

- i) *Masonry veneer* (with 40 mm cavity)
- ii) *Stucco*
- iii) Horizontal profiled metal – corrugated and *trapezoidal* only
- iv) Rusticated weatherboards
- v) Fibre cement weatherboards
- vi) Fibre cement sheet
- vii) Plywood sheet
- viii) *EIFS*.

Amend 2
Jul 2005

Amend 2
Jul 2005

3.4.2.2 Cladding options – north and east elevations

Cladding options from Table 3, for east and north faces, are:

- a) *Direct fixed claddings*:
 - i) Timber weatherboards – all types
 - ii) Fibre cement weatherboards
 - iii) Vertical profiled metal – corrugated and symmetrical *trapezoidal* only

- iv) Fibre cement sheet
- v) Plywood sheet
- vi) *EIFS*, and
- b) Wall *cladding* with a nominal 20 mm *drained cavity*:
 - i) *Masonry veneer* (with 40 mm cavity)
 - ii) *Stucco*
 - iii) Horizontal profiled metal – corrugated and *trapezoidal* only.

Amend 2
Jul 2005

Amend 2
Jul 2005

3.4.3 Example 3

The third example illustrates the use of the *risk matrix* for a complex *building*.

COMMENT:

The combination of features present on the south elevation results in a very high *risk score*. The presence of a *parapet* at the roof, *decks*, *enclosed balustrade-to-wall* junctions and *pergola* connections all contribute to this risk. The site is in a High *wind zone*.

The *risk score* is sufficiently high that the south elevation would require *specific design*, or redesign to lower the risk.

Specific design may result in the *building consent authority* possibly:

- a) Needing more details to be provided,
- b) Requiring more inspections during *construction*,
- c) Requiring a third party audit of the design.

The east and west elevations also score very highly at 18-20, and would require a *cladding* with a cavity such as vertical profiled steel, *masonry veneer* or any other *cladding* with a nominal 20 mm *drained cavity*.

The north elevation scores 14, so would require the use of the same *cladding* option as the east and west elevations.

Amend 2
Jul 2005

Amend 2
Jul 2005

Amend 2
Jul 2005

Amend 2
Jul 2005

Figure 4: Risk matrix example 3

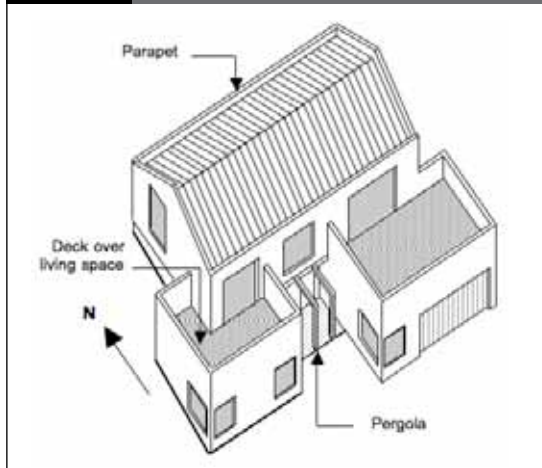

Table 6: Risk matrix example 3 – south elevation

| Risk factor | Risk severity | | | | | | | | |
|-------------------------------|---------------|-------|--------|----------|------|----------|-----------|----------|--------------------------------|
| | LOW | score | MEDIUM | score | HIGH | score | VERY HIGH | score | Subtotals for each risk factor |
| Wind zone (per NZS 3604) | 0 | | 0 | | 1 | 1 | 2 | | 1 |
| Number of storeys | 0 | | 1 | 1 | 2 | | 4 | | 1 |
| Roof/wall intersection design | 0 | | 1 | | 3 | | 5 | 5 | 5 |
| Eaves width | 0 | | 1 | | 2 | | 5 | 5 | 5 |
| Envelope complexity | 0 | | 1 | | 3 | | 6 | 6 | 6 |
| Deck design | 0 | | 2 | | 4 | 4 | 6 | | 4 |
| Total risk score: | | | | | | | | | 22 |

3.4.3.1 Cladding options – south elevation

As the south face scores over 20, it will require:

Amend 2
Jul 2005

- a) *Specific design*, or
- b) Redesigning the proposal to reduce the risk, so reducing the *risk score*.

3.4.3.2 Cladding options – other elevations

As the other faces score from 14 to 20, *cladding* options from Table 3 are:

Amend 2
Jul 2005

- a) *Direct fixed claddings*:
 - i) Vertical corrugated metal, and
- b) Wall *cladding* with a nominal 20 mm *drained cavity*:
 - i) *Masonry veneer* (with 40 mm cavity)
 - ii) *Stucco*
 - iii) Horizontal profiled metal – corrugated and *trapezoidal* only
 - iv) Rusticated weatherboards
 - v) Fibre cement weatherboards
 - vi) Fibre cement sheet
 - vii) Plywood sheet
 - viii) *EIFS*
 - ix) Bevel-back weatherboards.

Amend 2
Jul 2005**4.0 Flashings****4.1 Materials for flashings**

Acceptable materials for *flashing* junctions and penetrations are described in Paragraph 4.3.

4.2 Selection of flashing materialsAmend 5
Aug 2011

Flashing materials shall take into account the following factors:

- a) The requirements of NZBC Clause B2 Durability,
- b) The environment where the *building* is located,
- c) The specific conditions of use, and
- d) Consideration of the surrounding materials.

Amend 5
Aug 2011Amend 2
Jul 2005**COMMENT:**

Generally, the *durability* requirements for *flashings* specified in B2 are:

- a) 50 years, where *flashings* are:
 - i) completely hidden behind *claddings* such as *masonry veneer*, or
 - ii) not accessible,
- b) 15 years, where *flashings* are:
 - i) exposed, partially exposed, or
 - ii) accessible.

Two part *flashings* allow replacement of the *flashing* without *cladding* alteration.

An example of a two part *flashing* is shown in Figure 7.

Amend 2
Jul 2005**4.2.1 Environment**

Flashing materials shall be selected according to the relevant exposure conditions as defined in Table 20 to minimise corrosion.

COMMENT:

The exposure zone in which a *building* is located can affect the *durability* of *flashings*.

Exposure zones are defined in NZS 3604, based on the likely exposure to wind-driven sea-salt. Corrosion due to geothermal or corrosive industrial atmospheres, as defined in NZS 3604, require *specific design*.

Exposure zones are based on AS/NZS 2728. AS/NZS 2728 lists atmospheric classes derived from ISO 9223 for Australia and New Zealand.

Amend 5
Aug 2011

Amend 5
Aug 2011

4.2.2 Surrounding materials

Metals which are in contact in locations where they will become wet, or where water can flow over metals or certain plastics onto another metal, shall be selected in accordance with Table 21 and Table 22.

Uncoated metals shall not be used where carbon deposits or chemical contaminants may accumulate.

COMMENT:

Undesirable effects can occur when some materials are in contact with each other. Examples are corrosion of metals, stress cracking of plastics and staining of glass.

Carbon deposits such as soot will cause accelerated corrosion of damp uncoated metal.

4.3 Acceptable flashing materials

Amend 5
Aug 2011

Tables 20, 21 and 22 shall be used to assess suitability of *flashing* materials for the required *durability*.

COMMENT:

Additional guidance on *flashing* materials can be found in the New Zealand Metal Roof and Wall Cladding Code of Practice.

4.3.1 uPVC flashings

Amend 2
Jul 2005

uPVC *flashings* shall be a minimum of 0.75 mm thick.

uPVC *flashings* shall comply with the requirements of the following Clauses of AS/NZS 4256: Part 2:

- a) Clause 9.2 Impact resistance,
- b) Clause 9.3 Tensile strength, and
- c) Clause 9.4 Colourfastness and impact resistance following ultraviolet light exposure.

Where uPVC *flashings* are exposed to the weather, they shall also comply with Section 8 of AS/NZS 4256: Part 2.

uPVC *flashings* shall have a finish colour with a reflectance of 40% or more, as outlined in Paragraph 2.4.

COMMENT:

Manufacturers of uPVC *flashings* which have a proven performance in use may be able to show compliance with NZBC Clause B2 Durability as detailed in B2/VM1.

4.3.2 Aluminium flashings

Aluminium *flashings* shall be a minimum thickness of 0.7 mm, and formed from 5000 series in accordance with AS/NZS 1734.

Amend 2
Jul 2005

Amend 5
Aug 2011

4.3.3 Galvanized steel flashings

Galvanized steel *flashings* shall:

- a) have a *BMT* of 0.55 mm minimum
- b) be grade G550, or G300 for rolled or crimped *flashings*
- c) be selected for corrosion protection according to the intended exposure zone as shown in Table 20.

Amend 2
Jul 2005

Amend 5
Aug 2011

4.3.4 Aluminium-zinc coated steel flashings

Aluminium-zinc coated steel *flashings* shall:

- a) have a *BMT* of 0.55 mm minimum
- b) be grade G550, or G300 for curved or crimped *flashings*
- c) be selected for corrosion protection according to the intended exposure zone as shown in Table 20.

Amend 5
Aug 2011

Amend 2
Jul 2005

4.3.5 Stainless steel flashings

Stainless steel *flashings* shall be:

- a) Minimum thickness of 0.45 mm, and
- b) 304 or 316 stainless steel in accordance with Table 1 of ISO/TS 15510.

Amend 2
Jul 2005

Amend 5
Aug 2011

Amend 2
Jul 2005

4.3.6 Copper flashings

Copper *flashings* shall be:

Amend 2
Jul 2005

- a) A minimum thickness of 0.5 mm,
- b) In compliance with AS 1566, and
- c) Alloy, designation C11000 or C12200.

4.3.7 Lead sheet flashings

Lead sheet *flashings* shall:

- a) Comply with AS 1804, and
- b) Have a minimum unit mass of 17 kg/m².

Amend 2
Jul 2005**4.3.8 Zinc sheet flashings**

Zinc sheet *flashings* shall only be used in accordance with Tables 20, 21 and 22.

Zinc sheet *flashings* shall be:

- a) A minimum thickness of 0.7 mm, and
- b) In compliance with BS EN 988.

4.3.9 Butyl rubber and EPDM flashingsAmend 5
Aug 2011

Butyl rubber *flashings* shall only be used in accordance with Tables 20, 21 and 22.

Butyl rubber and EPDM *flashings* shall be a minimum thickness of 1.0 mm, and shall comply with the following parts of Table 1 in ASTM D6134:

- a) Tensile strength,
- b) Elongation,
- c) Water absorption,
- d) Water vapour permeance, and
- e) Heat aging followed by:
 - i) tensile strength
 - ii) elongation.

4.3.10 Bituminous flashings

Bituminous *flashings* shall only be used in accordance with Table 20.

Flashings made from bitumen-impregnated material shall:

- a) Comply with AS/NZS 2904, and
- b) Be used only in fully concealed applications.

4.3.11 Flexible flashing tapeAmend 5
Aug 2011

Flexible flashing tape shall comply with Parts 3.2 and 4 of ICBO Acceptance Criteria AC148, shall be compatible with adjacent *building wall underlay* or *roof underlay*, and be used only in fully concealed applications.

4.4 Fixings

Fixings of metal *flashings* shall comply with Tables 20, 21 and 22.

Amend 5
Aug 2011

Exposed *flashings* such as barge and ridge *flashings* are to be fixed along both edges.

Amend 2
Jul 2005**COMMENT:**

Fixings that penetrate *flashings* should be avoided where possible.

Amend 5
Aug 2011**4.5 Flashing requirements**

All *flashings* shall have *expansion joints* where required in Paragraph 4.5.2 to provide for thermal expansion.

Amend 5
Aug 2011

Flashings are required to shed or divert water at sensitive areas of the *building cladding*.

These include at:

- a) The *building* periphery, except where gutters are present,
- b) Changes of direction in *cladding* materials,
- c) Intersections between *cladding* materials or with other *buildings*, and
- d) Roof or wall penetrations, including windows, doors and other penetrations.

4.5.1 Edge treatments for flashings

Flashings shall be to the dimensions shown throughout this Acceptable Solution.

Amend 5
Aug 2011

Exposed bottom edges of *flashings* shall be folded to a *kick-out* or a *bird's beak* as shown in Figure 5.

For Low, Medium, High and Very High *wind zones*, *flashing upstands* shall have either:

- 1) A *hem* or *hook* to Figure 5, with upstand dimensions as shown throughout the document, or
- 2) No *hooks* or *hems*, and *flashing upstand* dimensions increased by 25 mm beyond those shown.

For Extra High *wind zones*, *hooks* and *hems* shall be used, and *flashing upstand* dimensions increased by 25 mm beyond those shown in Table 7 or elsewhere in the document.

Amend 2
Jul 2005
Amend 5
Aug 2011**COMMENT:**

Refer to the New Zealand Metal Roof and Wall Cladding Code of Practice for further edge treatments.

Amend 2
Jul 2005

4.5.2 Metal flashing joints

Where metal flashings require to be joined, the method shall be as shown in Figure 6. Joints of metal flashings shall have the following features:

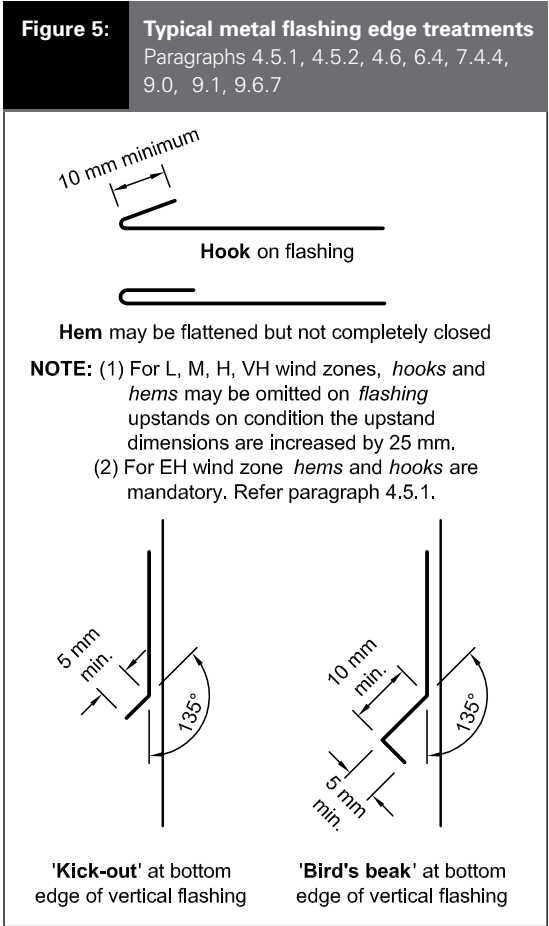

- a) Rivets used for joining and sealing laps shall be spaced at a maximum of 50 mm centres, and be:
 - i) compatible with the flashing material as per Table 21 and Table 22, and
 - ii) sealed against moisture, or
 - iii) of a sealing type or blind rivet,
- b) Expansion joints shall be provided for joined flashings with a combined length exceeding:
 - i) 12 metres for light coloured steel and stainless steel. 8 metres for dark coloured steel,
 - ii) 8 metres for copper,
 - iii) 8 metres for aluminium.
- c) Where both ends of a flashing are constrained, allowance shall be made for expansion,
- d) Where necessary, expansion joints shall be formed as shown in Figure 6, with:
 - i) minimum 200 mm laps, and
 - ii) sliding clips at both sides of the lap,
- e) When using uncoated galvanized steel, zinc, stainless steel or copper flashings, joints shall be riveted or soldered as described in the New Zealand Metal Roof and Wall Cladding Code of Practice,
- f) When using uncoated or coated lead flashings, maximum continuous lengths shall be 1300 mm for 17 kg or 1500 mm for 20 kg lead. Where the pitch of the flashing is greater than 15° at the joint, the lap at the joint shall be 100 mm minimum.

Amend 5 Aug 2011

Amend 2 Jul 2005

Amend 2 Jul 2005

Amend 2 Jul 2005

Amend 5 Aug 2011

Amend 5 Aug 2011

Amend 2 Jul 2005

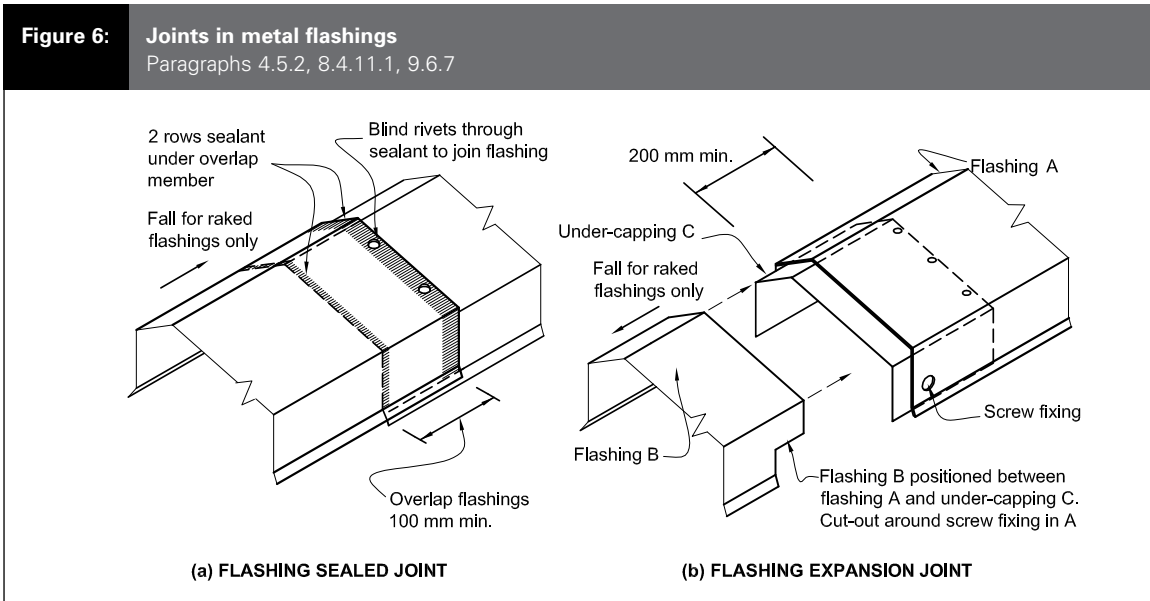

Amend 2
Jul 2005

Where the pitch of the *flashing* is 15° or less at the join, the lap at the join shall be 200 mm minimum and the *flashing* underneath the lap shall have a *hook* at the edge,

- g) Lap joins on other metal *flashings* shall be sealed using a neutral cure silicone sealant in conjunction with mechanical fasteners. The sealant shall comply with:
- Type F, Class 20LM or 25LM of ISO 11600, or
 - low modulus Type II Class A of Federal Specification TT-S-00230C.

COMMENT:

Further information may be found in the New Zealand Metal Roof and Wall Cladding Code of Practice for joints in metal *flashings*.

Amend 5
Aug 2011**4.6 Flashing overlaps and upstands**

Overlaps and upstands to *flashings* shall be as specified in this paragraph and Table 7, unless specifically shown otherwise. Refer to Paragraph 8.1 to Paragraph 9.9 for requirements for specific *claddings*.

Flashing edges, with *hooks*, *hems*, *kick-outs* and *bird's beaks* shall be as required in Table 7 and Paragraph 4.5.1.

Amend 5
Aug 2011

Where a turn-down to the cover *flashing* for profiled metal *claddings* is required, use:

- A *soft edge flashing* for corrugated profiles, or
- A notched turn-down or soft edge *flashing* for *trapezoidal* profiles with rib height not exceeding 30 mm and/or rib centres not exceeding 200 mm, or
- A notched turn-down for *trapezoidal* profiles with rib height exceeding 30 mm and/or rib centres exceeding 200 mm, or
- A notched turn-down for *trough profiles*.

Amend 5
Aug 2011

Where a notched turn-down is used there shall be a gap between the edge of the *flashing* and the pan of the roof *cladding*.

Amend 2
Jul 2005

The gap shall be a maximum of 5 mm.

4.6.1 Overlap with roof claddings**4.6.1.1 Apron flashing cover over metal roofing****a) Transverse flashing:**

Refer to Figure 7 for example of use. The apron shall have:

- for notched turn-downs, a gap between the *flashing* and the pan of the roof *cladding*. The gap shall be a maximum of 5 mm, and
- a minimum effective cover to roof *cladding*, excluding any *soft edge* or turn-down to the *flashing*, as shown in Table 7.

Amend 2
Jul 2005Amend 2
Jul 2005**b) Parallel flashing:**

Refer to Figure 48 for example of use. The apron shall:

- be dimensioned to suit the roof *cladding* profile,
- for profiled metal roof *cladding*, cover at least two crests, (turned-up edge to full crest height constitutes a crest), and
- for profiled metal roof *cladding*, overhang *flashing* a minimum 10 mm clear of crest and maximum 5 mm clear of trough as shown in Figure 47.

Amend 2
Jul 2005Amend 5
Aug 2011**4.6.1.2 Ridges and hips**

Refer to Figure 46 for example of use.

- For notched turn-downs of the *flashing* leave a gap between the *flashing* and the roof *cladding*. The gap shall be a maximum of 5 mm.
- There shall be a minimum effective cover to roof *cladding*, excluding any *soft edge* or turn-down to the *flashing*, in accordance with Table 7.

Amend 2
Jul 2005**4.6.1.3 Change in metal roof pitches**

Refer to Figure 44 for example of use.

- There shall be a minimum effective lap under roof *cladding* in accordance with Table 7, with a *hem* at upper edge.
- The apron cover over the roof *cladding* shall be in accordance with Table 7.

Amend 2
Jul 2005

4.6.1.4 Roof- or deck-to-wall junctions

Refer to Figure 7 for example of use.

- a) There shall be a total minimum upstand height of 110 mm, in accordance with Table 7, comprising a minimum:
 - i) overlap cover of *cladding* to the *flashing* upstand of 75 mm, and
 - ii) 35 mm clearance from bottom of the wall *cladding* to *roof cladding* or finished *deck* material.

Amend 2
Jul 2005

Amend 5
Aug 2011

| Table 7: Metal flashings – general dimensions Paragraphs 4.6, 4.6.1.1, 4.6.1.2, 4.6.1.3, 4.6.1.4, 4.6.1.5, 4.6.1.6, 4.6.1.7, 5.1, 6.4, 6.5, 7.4.4, 8.3.8, 9.1.3, 9.1.10.2, 9.1.10.4 and 9.4.5.3 | | | | | | |
|---|--|--------------------|--|----------------------------------|--------------------------------------|---|
| Type | Description | All (1) | Situation 1 (2) minimum mm | Situation 2 (3) minimum mm | Situation 3 (3a) minimum mm | Figure reference (as example) |
| Aprons: general | <i>Transverse flashing</i> over roofing | | 130 (4) | 200 (4) | 200 mm | Figure 7 and Figure 44 (X values) |
| | <i>Parallel flashing</i> over roofing | | Two crests, finish in next trough – refer 4.6.1.1b) | | | Figures 47, 48 (Y values) |
| Ridges/ hips | <i>Transverse flashing</i> over roofing | | Refer Aprons: general | | | Figures 43, 45b, 46 |
| Changes in roof pitches | Upper lap under roofing | 250 mm min. | | | Not permitted under E2/AS1 | Figure 44 |
| | <i>Transverse flashing</i> over roofing | | Refer Aprons: general | | | |
| Barges | Overlap to barge board | | 50 (8) | 70 (8) | 90 mm | Figure 47 (Z values) |
| Cappings | Overlaps to <i>cladding</i> | | 50 (8) | 70 (8) | 90 mm | Figure 10 (Z values) |
| | Slope to top: <i>parapet</i> and balustrade – metal capping | 5° min. | | | | Figures 10, 11, 12, 130 |
| | Slope to balustrade – <i>flush-finished EIFS</i> and fibre cement(5) | 10° min. | | | | Figures 117, 129, 130 |
| Roof or Deck to Wall – See membranes below | Overlaps to roofing | | Refer Aprons: general | | | |
| | Lap under <i>cladding</i> above | 75 mm min. | | | 90 mm | Figures 7, 26, 30, 35, 37, 44, 48, 50 |
| | Clearance below <i>cladding</i> | 35 mm min. | | | | |
| | Total upstand | 110 mm min. | | | | |

Amend 5
Aug 2011

| Table 7: continued | | Metal flashings – general dimensions | | | | | |
|---|---|---|-----------------------------------|-----------------------------------|------------------------------------|--------------------------------------|-------------------------|
| | | Paragraphs 4.6, 4.6.1.1, 4.6.1.2, 4.6.1.3, 4.6.1.4, 4.6.1.5, 4.6.1.6, 4.6.1.7, 5.1, 6.4, 6.5, 7.4.4, 8.3.8, 9.1.3, 9.1.10.2, 9.1.10.4 and 9.4.5.3 | | | | | |
| Membrane roofs and decks | Lap under <i>cladding</i> above | 115 min. | | | | | Figures 18, 62a, c, 64b |
| Type | Description | All (1) | Situation 1 (2) minimum mm | Situation 2 (3) minimum mm | Situation 3 (3a) minimum mm | Figure reference (as example) | |
| Windows | Window flange clearance for <i>direct fixed claddings</i> and ply or fibre cement on cavities | 5 mm | | | | | Eg. Figure 81 |
| | Cover to window/door jamb flange | 10 mm(7) min. | | | | | Eg. Figure 81c |
| | Cover to window/door sill flange | 8 mm(7) min. | | | | | Eg. Figure 81c |
| Sills | Sill <i>flashing</i> slope (6) | Flat(6) | | | | | Eg. Figures 72a, 81b |
| Heads | Head <i>flashing</i> slope | 15° min. | | | | | Eg. Figure 81a |
| | Lap under <i>cladding</i> above | 35 mm min. | | | 60 mm | | Eg. Figure 81a |
| | Anti-capillary gap to <i>cladding</i> | 5 mm | | | | | Eg. Figure 81a |
| | Total upstand | 40 mm min. | | | | | |
| Corners | Corner <i>flashings</i> (1) | 50 mm x 50 mm minimum | | | 75 x 75 mm | | Eg. Figure 79 |
| Inter-storey junctions | Junction <i>flashing</i> : slope | 15° min. | | | | | Figure 70 |
| | Lap over <i>cladding</i> below (1) | 35 mm min.(8) | | | 60 mm | | |
| | Lap under <i>cladding</i> above | 35 mm min. | | | 60 mm | | |
| | Clearance under <i>cladding</i> | 5 mm min. | | | | | |
| | Total upstand | 40 mm min. | | | | | |
| <p>NOTES: (1) Unless otherwise dimensioned in details. (2) Situation 1: Low, Medium, High <i>wind zones</i>, where roof pitch $\geq 10^\circ$ (X or Z values) (3) Situation 2: All roof pitches in Very High <i>wind zones</i>, Low, Medium and High <i>wind zones</i> where roof pitch $\leq 10^\circ$. (X or Z values) (3a) Situation 3: For all roof pitches in Extra High <i>wind zone</i>. (4) Excluding any <i>soft edge</i> or turn-down to roofing. (5) For <i>buildings</i> other than housing, slope shall be as per F4/AS1. (6) For <i>direct fixed window/doors</i>, unless shown. Sill <i>flashing</i> must extend past the condensation channel. Ensure sill <i>flashings</i> are not installed with backwards slope. (7) Excluding <i>drip edge</i>. (8) Excluding <i>drip edge</i>.</p> | | | | | | | |

Amend 2
Jul 2005

Amend 5
Aug 2011

Amend 5
Aug 2011

Amend 2
Jul 2005

Errata 2
Dec 2011

Amend 5
Aug 2011

Figure 7: Basic apron flashing
Paragraphs 4.6.1.1, 4.6.1.4, 5.1, 8.3.8 and Table 7

NOTE: *Stopens* to profiled metal - refer Figure 49

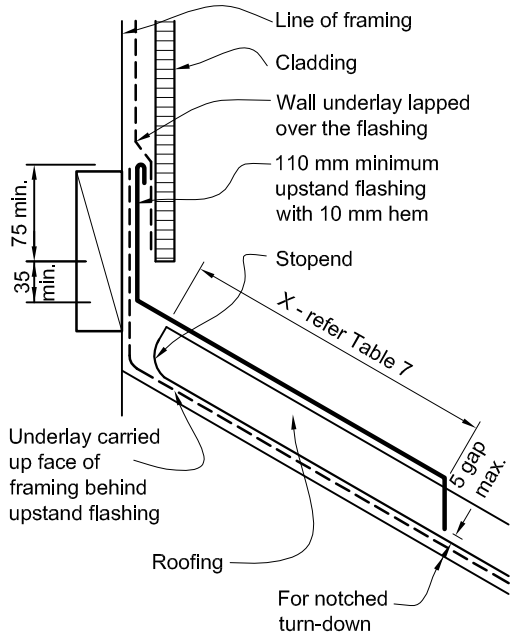

(a) ONE PART FLASHING

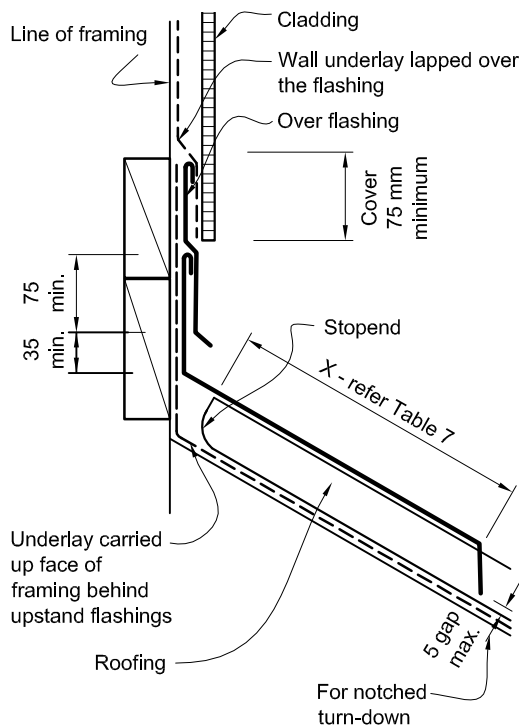

(b) TWO PART FLASHING (OPTIONAL)

4.6.1.5 Barges

Refer to Figure 47 for example of use.

- a) There shall be a minimum effective overlap to the barge board, excluding the *drip edge* to the *flashing*, in accordance with Table 7.
- b) The apron cover over the *roof cladding* shall be as for Paragraph 4.6.1.1.

4.6.1.6 Window and door heads

Refer to Figures 71 and 81 for example of use.

- a) Slopes and covers of *flashings* at window and door heads shall comply with Table 7.
- b) Overlap cover of *cladding* to the *flashing* upstand and clearance from the bottom of the *cladding* to top of head *flashing* slope shall be in accordance with Table 7.
- c) Details for door heads shall be based on those applying to windows.

Amend 5
Aug 2011

Amend 5
Aug 2011

4.6.1.7 Inter-storey junctions

Refer to Paragraph 9.1.9.4 and Figure 70.

- a) Minimum slopes and covers of *flashings* shall be in accordance with Table 7.
- b) Overlap cover of the *cladding* to the *flashing* upstand, and clearance from the bottom of the *cladding* to the top of the slope of the head *flashing*, shall be in accordance with Table 7.

Amend 5
Aug 2011

5.0 Roof/Wall Junctions

5.1 Apron flashings

Refer Paragraph 4.3 for acceptable *apron flashing* materials.

All roof-to-wall junctions shall be made *weathertight* by using an *apron flashing* as outlined in Paragraph 4.6.1.1, and shown in Figure 7, that:

- a) Provides a minimum lap under the *wall cladding* of 75 mm in accordance with Table 7, except that:
 - i) pressed metal tiles shall have a *flashing* fitted to achieve the minimum required overlap of *wall cladding*, as shown in Figure 35,

Amend 5
Aug 2011

Amend 2
Jul 2005

Amend 2
Jul 2005

Amend 2
Jul 2005

Amend 5
Aug 2011

Amend 5
Aug 2011

Figure 8A: Soffit/wall junction
Paragraphs 5.3, 8.1.3.1, 8.4.6, 9.7.5, 9.8.6

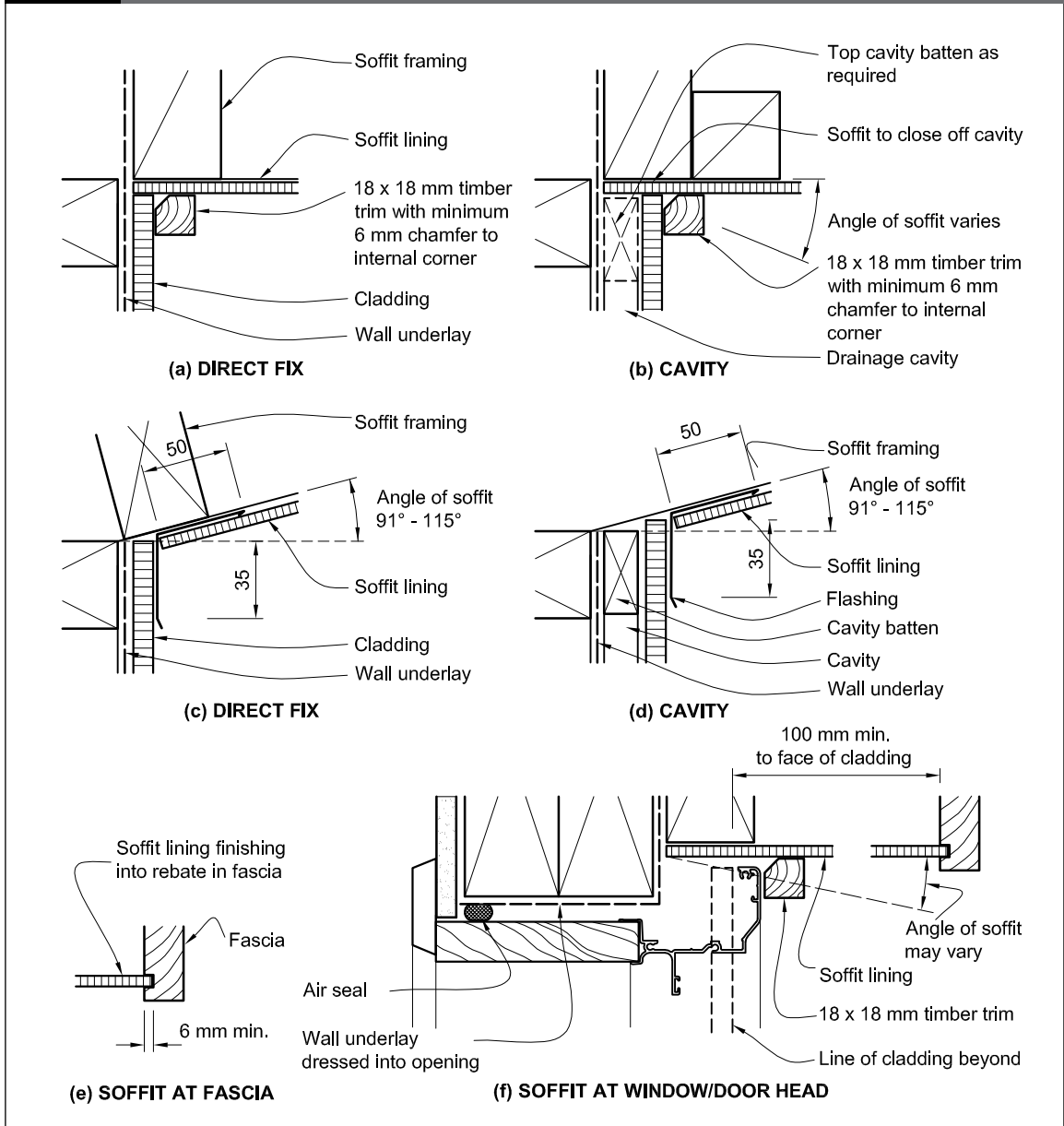

Errata 2
Dec 2011

Amend 2
Jul 2005

Amend 5
Aug 2011

- b) For profiled metal, incorporates *stopends* at the upper end of the *roof cladding* as per Paragraph 8.4.13,
- c) Provides a minimum clearance from the *wall cladding* to the roofing in accordance with Table 7, and
- d) Extends over the roofing by a minimum cover in accordance with Paragraph 4.6.1.1 and Table 7, depending on the:
 - i) *wind zone* and,
 - ii) *pitch of the roof*.

COMMENT:

40 mm is the maximum upturn achievable with pressed metal tiles, meaning that a *flashing* is required.

Details for specific *wall cladding* systems are given in Paragraph 9.0.

Where the roof finishes within the length of an adjacent *wall*, a *kick-out* or *stopend* as detailed in Figure 8B shall be provided to direct water out from the *wall cladding* onto the *roof cladding* and gutter.

Amend 2
Jul 2005

Amend 5
Aug 2011

Amend 2
Jul 2005

Figure 8B: Gutter/wall junction
Paragraphs 5.1 and 5.2

NOTE: (1) The upstand at the lower edge of the *apron flashing* may be preformed to a larger size and then trimmed on site to suit.
(2) The *transition flashing* bridges gap at the end of the fascia to protect the soffit *framing*.
(3) *Wall underlay* omitted for clarity.

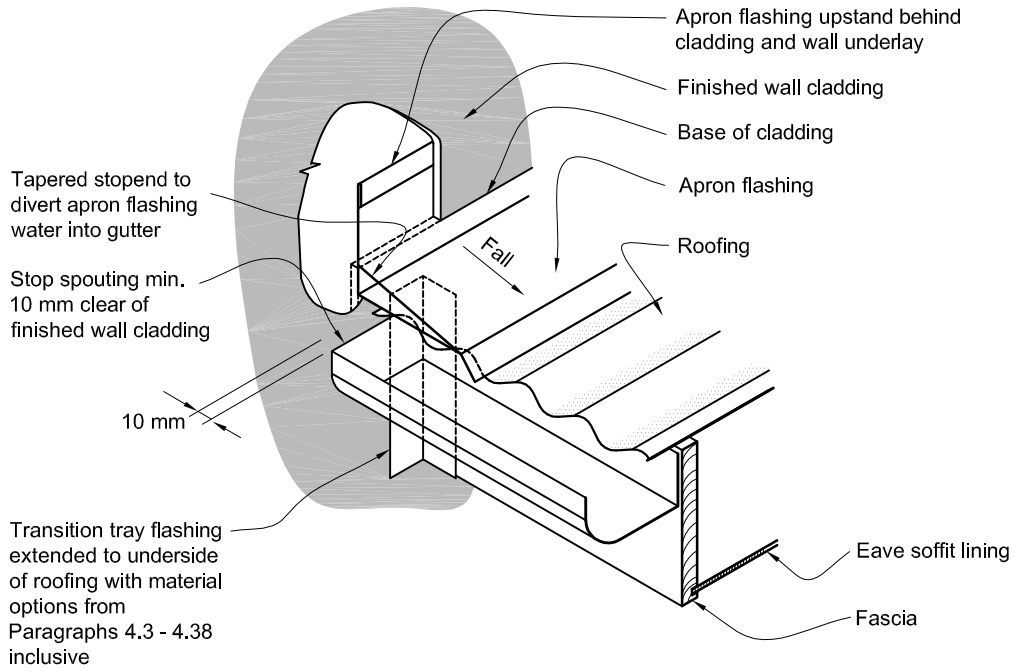

Amend 5
Aug 2011

5.2 Gutters, barges and fascias

Amend 5
Aug 2011

Where *eaves gutters/spoutings, barges or fascias* terminate against *claddings*, these shall be installed after the wall *cladding*, and after any protective finishes have been applied.

Eaves gutters/spouting, barges and fascias shall terminate so as to leave a gap of 10 mm from the finished *wall cladding* as shown in Figure 8B.

Amend 5
Aug 2011

COMMENT:

It is important to ensure the *wall cladding* behind *eaves gutters/spoutings, barges and fascias* is protected by the surface coating to prevent moisture penetration through the unsealed *cladding*.

Amend 5
Aug 2011

5.3 Soffits

Eaves shall be enclosed by installing soffit *linings direct fixed to framing* and comprising minimum 4.5 mm fibre cement sheet, or 7 mm H3 plywood, with joints, fixings and finishes as shown in Paragraphs 9.7 and 9.8. Soffit *linings* shall be finished to fascias, barges and *wall claddings* as outlined in Figure 8A generally, or Figure 114 for *flush finished* fibre cement. *Wall underlays* shall not be required behind soffit *linings*.

Amend 5
Aug 2011

6.0 Parapets

Parapets require a *drained cavity* for *claddings* except for vertical corrugated steel as outlined in Table 3. Refer also to Paragraph 7.4 Enclosed balustrades.

COMMENT:

Vertical corrugated profiled metal is considered to have drainage capabilities the equivalent of *drained cavities*.

Amend 5
Aug 2011

6.1 Limitations

This Acceptable Solution does not cover *parapet cappings* that use *stucco*, *EIFS* and *flush-finished* fibre cement materials.

Amend 5
Aug 2011

6.2 General

Parapets shall be *constructed* as shown in Figure 10, and shall comply with the following requirements:

Amend 5
Aug 2011

- a) Timber for *framing* and *cavity battens* shall comply with B2/AS1,
- b) Sloped packers under *cappings* shall be polystyrene or timber treated to B2/AS1, or minimum 9 mm H3 plywood on packers, and
- c) *Framing* shall be fully enclosed with *wall underlay* or *roof underlay*, in accordance with Table 23 for the specific *cladding*.
- d) *claddings* shall be installed over a cavity in accordance with Paragraph 9.1.8.

Amend 2
Jul 2005

Amend 5
Aug 2011

Details for specific *wall cladding systems* are given in Paragraph 9.0.

Specific requirements for *enclosed balustrades* are given in Paragraph 7.4.

6.3 Capping materials

Parapets shall be capped with metal, butyl or *EPDM membrane*. *Cappings* shall comply with the requirements of Paragraph 4.0.

Figure 9: General capping joints for parapets and enclosed balustrades
 Paragraphs 6.3, 6.4, 7.4.4, 9.3.7, 9.9 and 10.2

NOTE: Capping joints and fixings - refer Paragraph 4.5.2 and Figure 9

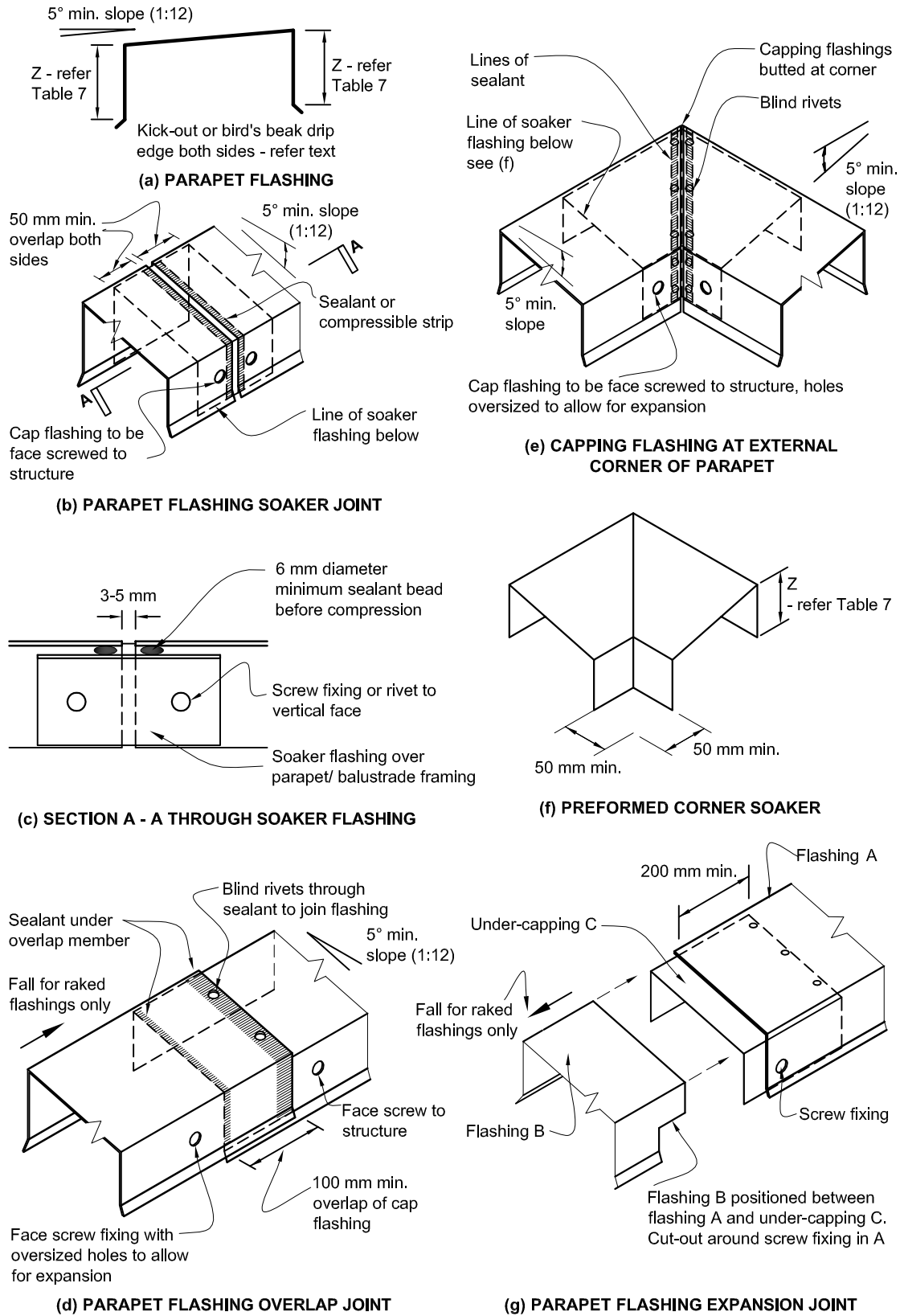

Amend 2
 Jul 2005

Amend 5
 Aug 2011

Figure 10: General construction of parapet and enclosed balustrade
Paragraph 6.0, 6.2, 6.4, 7.4, 9.7.7.1, Figures 12, 13, 117, 129 and 130

NOTE: Capping joints and fixings - refer Paragraph 4.5.2 and Figure 9

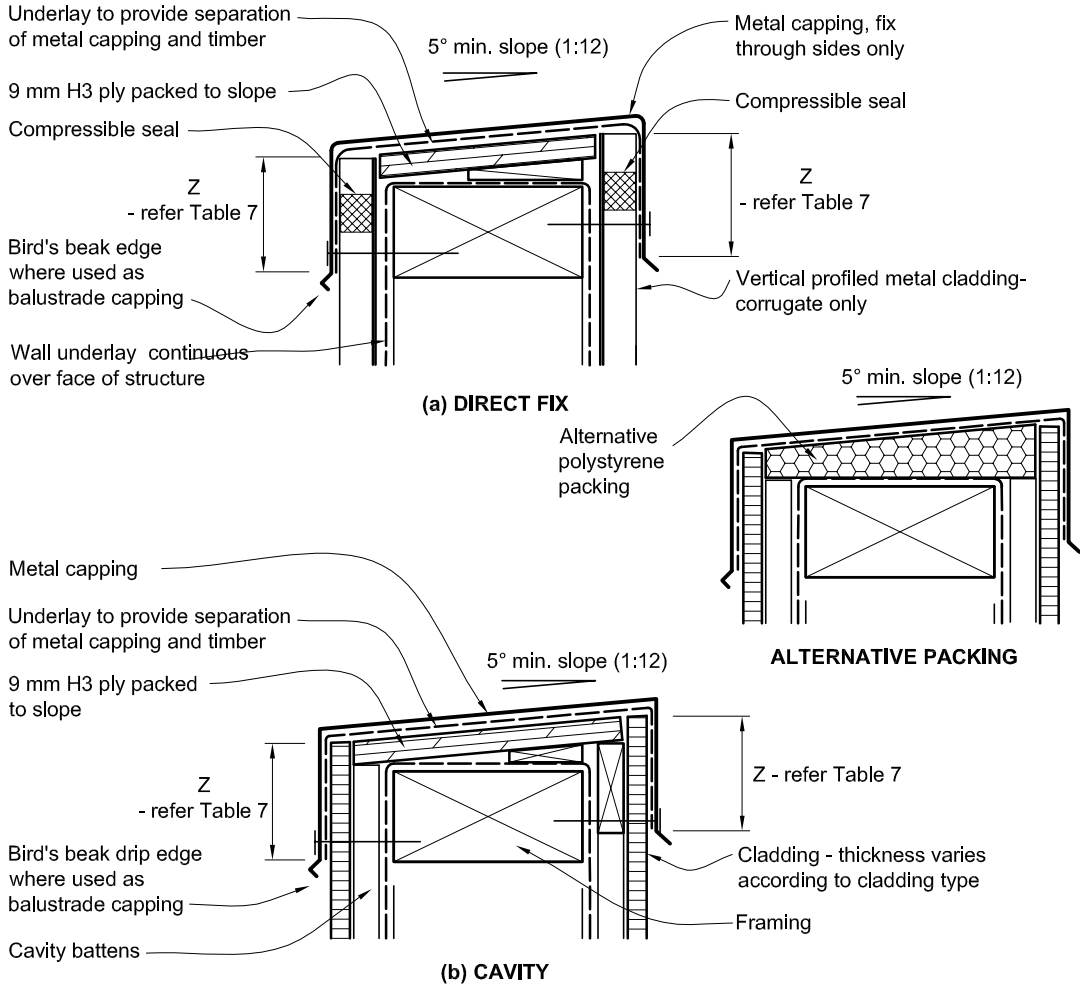

Amend 5
Aug 2011

6.4 Metal cappings

Metal *cappings* installed over *parapets* and *enclosed balustrades*, shall be as outlined in Paragraphs 6.0 and 7.4, and comply with the following requirements:

- a) Tops of *cappings* shall be free of any penetrations,
- b) Slope of top shall be 5° (1:12) minimum,
- c) The cover at the sides of the *capping* shall be in accordance with Table 7,
- d) All *cappings* shall have *drip edges*. The details shown in Figure 5 are acceptable minimum *drip edges* for *parapets*,
- e) *Cappings* shall be separated from underlying timber by *roof underlay* as shown in Figure 10,
- f) Lengths of *capping* shall be joined as shown in Figure 9 (b) or Figure 9 (d),
- g) External corners of *cappings* shall be as shown in Figure 9 (e),
- h) *Expansion joints* shall be provided for joined *cappings* with a combined length exceeding:

Amend 5
Aug 2011

Amend 2
Jul 2005

- i) 12 metres for light coloured steel and stainless steel, 8 metres for dark coloured steel
- ii) 8 metres for copper
- iii) 8 metres for aluminium.

Amend 2
Jul 2005

- i) Where both ends of a *capping* are constrained, allowance shall be made for expansion, and
- j) Where necessary, *expansion joints* shall be formed as shown in Figure 9 (g), and with:
 - i) minimum 200 mm laps
 - ii) sliding clips at both sides of the lap.

Amend 5
Aug 2011

Any textured coating application, except for the finished coat, over *flush-finished cladding* shall be completed prior to the installation of metal *cappings*.

6.4.1 Parapet-to-wall junctions

Junctions of *parapets* to *walls* shall be flashed to direct water clear of the outside face of the *cladding system*, using a *saddle flashing* as shown in Figure 11 and Figure 12.

Amend 5
Aug 2011

Parapets that are continuous and in-plane with adjacent *wall* surfaces are outside the scope of this Acceptable Solution. An offset in *wall* line between *parapet* and adjacent *wall* is required as in Figures 11 and 12.

COMMENT:

Reports on leaky *buildings* show these junctions have been prone to leakage and care must be taken to detail and build them correctly.

Amend 5
Aug 2011

In-plane junctions require specific design of *flashing* arrangements.

6.5 Membrane cappings

Butyl rubber and *EPDM cappings* shall be in accordance with Paragraph 4.3.9, and comply with the following requirements:

- a) Tops of *membrane cappings* shall be free of any penetrations, and shall have a minimum slope of 10° (1:6),
- b) Sides of *membrane cappings* shall overlap the *wall claddings* as outlined in Table 7, and
- c) Joints shall be in accordance with Paragraph 8.5.5.2.

Amend 5
Aug 2011

6.6 Integral surface cappings

Cappings formed by using *stucco*, *EIFS* and *flush-finished* fibre cement materials shall not be used for *parapets*, (but may be used for *enclosed balustrades* as described in Paragraph 7.4).

COMMENT:

The tops to *parapets* are considered to be more risky locations than the tops to *enclosed balustrades*, as they are less accessible for inspection and regular maintenance.

Amend 5
Aug 2011

Figure 11: Parapet/enclosed balustrade-to-wall junctions – plan section
 Paragraphs 6.4.1, 7.4.2, 7.4.4.1 and 7.4.4.2, Figures 10, 12, 117, 129 and 130

NOTE: (1) Refer Figure 12 for *saddle flashing* and *capping* to wall junction.
 (2) Plan section is through balustrade or *parapet framing*, below *capping* packer.

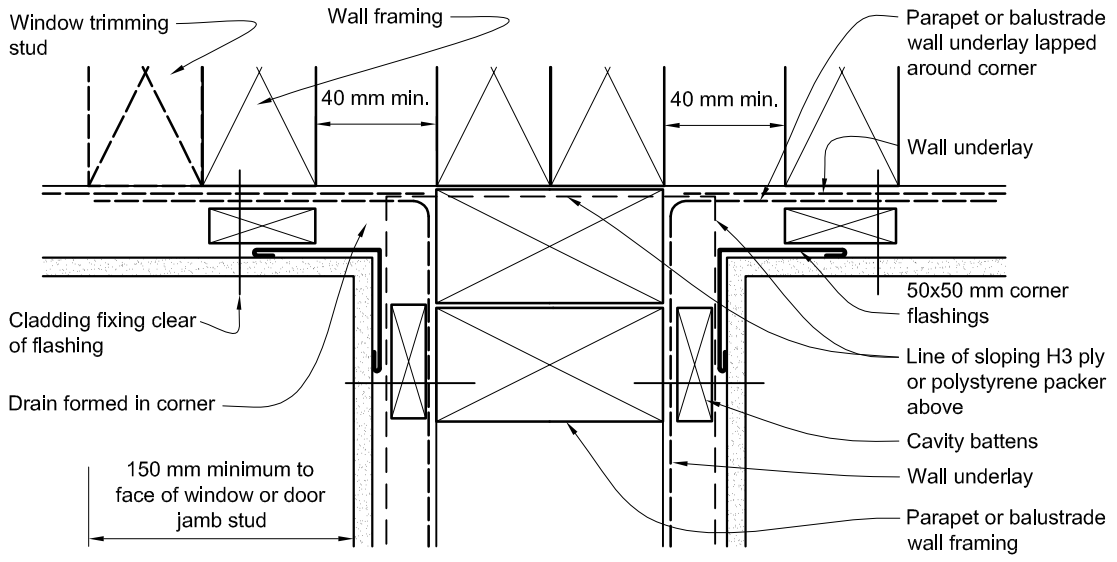

Errata 2
 Dec 2011

Amend 5
 Aug 2011

Figure 12: General junction of parapet and enclosed balustrade to wall
 Paragraphs 6.4.1, 7.4.2, 7.4.4.1, 7.4.4.2 and 9.9.10.1, Figures 10, 12, 117, 129 and 130

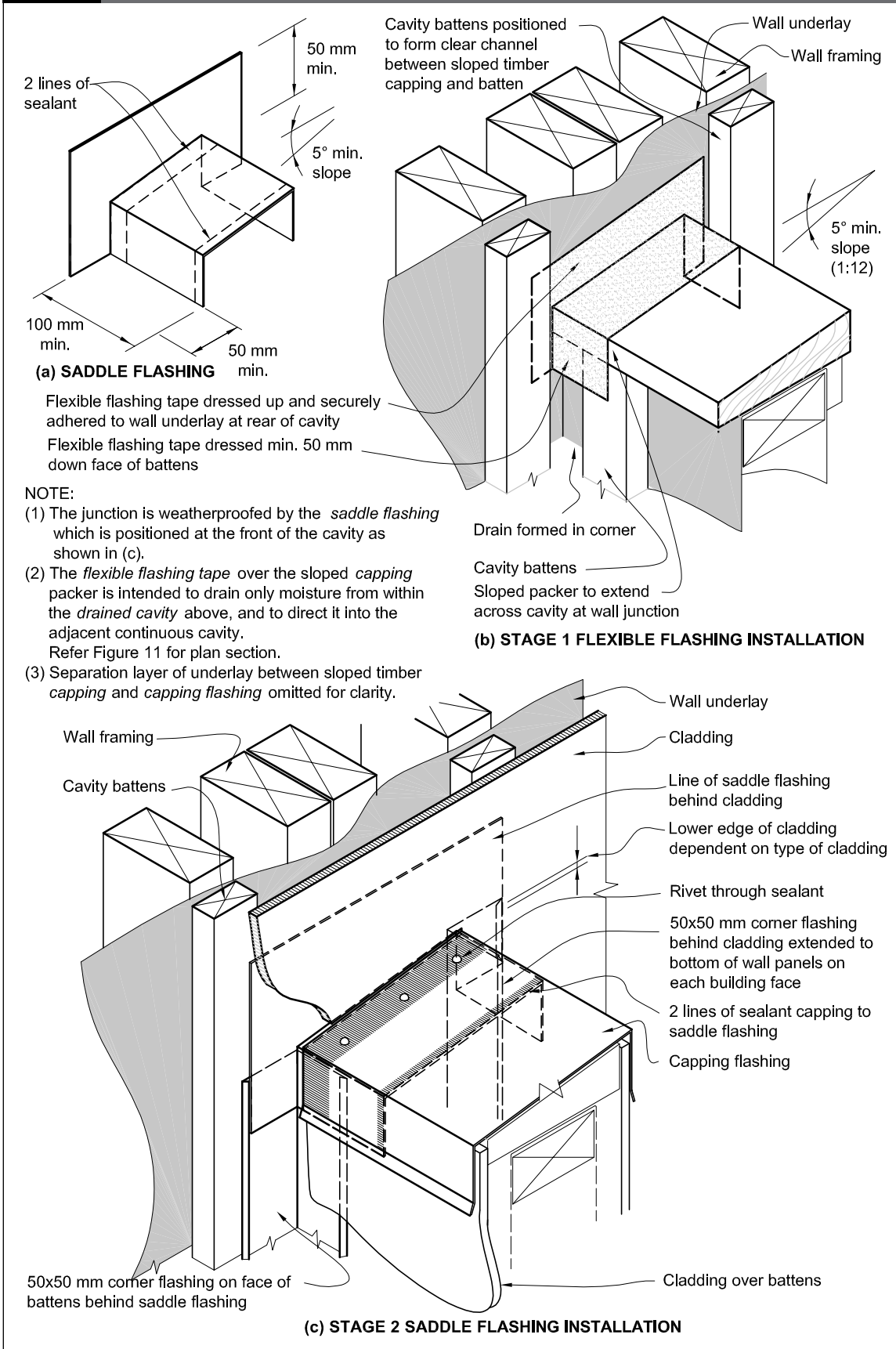

Amend 2
 Jul 2005

Amend 5
 Aug 2011

Figure 13 deleted

7.0 Decks and Pergolas

Timber used to construct *decks*, *enclosed balustrades* and other attachments such as pergolas shall comply with B2/AS1.

Amend 5
Aug 2011

7.1 Thresholds for decks

The vertical separation between the opening threshold level and the upper surface of the *deck* shall be as shown in Figure 14.

Amend 5
Aug 2011

Opening threshold level may be at or above floor level.

Amend 5
Aug 2011

7.1.1 Slatted decks

The level of the upper surface of the slatted *deck*:

Amend 5
Aug 2011

- Shall be a minimum of 50 mm below the threshold level for *cantilevered decks* as shown in Figures 14(b) and 16, or
- May be at the same level as the threshold for non-cantilevered *decks* that are formed as shown in Figure 14(c).

Amend 5
Aug 2011

Amend 5
Aug 2011

For slatted *decks*, a minimum gap of 12 mm shall be provided between the exterior *wall* and the adjacent decking slat.

Amend 5
Aug 2011

7.1.2 Enclosed decks

This Acceptable Solution is limited to *enclosed decks* with a maximum area of 40 m².

For *enclosed decks*, the vertical separation between the opening threshold level and the upper surface of the finished *deck* surface shall be a minimum of 100 mm.

Amend 5
Aug 2011

Figure 14: Threshold separations
Paragraphs 7.1, 7.3, 8.5.6, Figures 17A, 56, 62 and 64

NOTE: Threshold level may be above floor level.

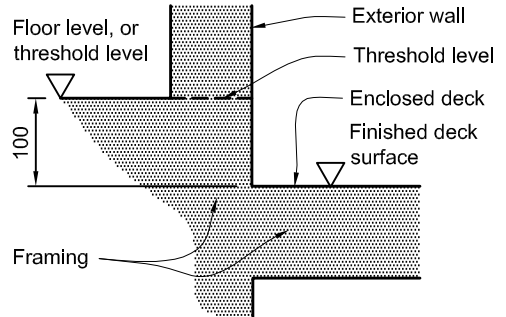

(a) ENCLOSED DECKS

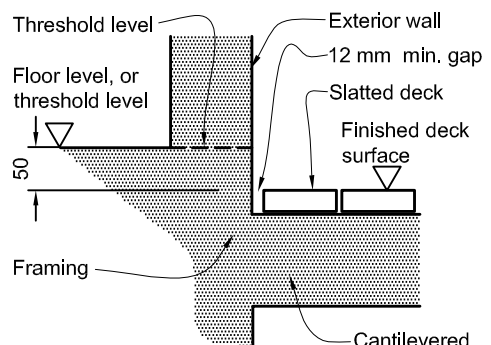

(b) SLATTED DECKS
CANTILEVERED

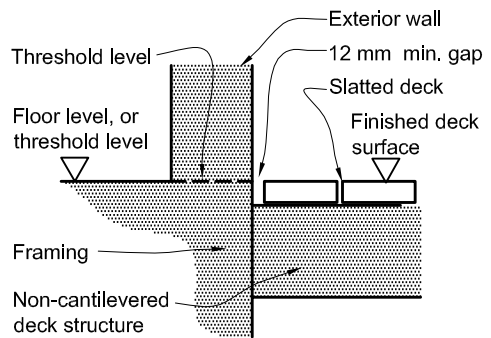

(c) SLATTED DECKS
NON-CANTILEVERED

Amend 5
Aug 2011

7.2 Attachment to building structure

7.2.1 Slatted timber decks to walls

Junctions of slatted timber *decks* with *walls* shall be made *weathertight* as shown in Figures 15 and 16.

Amend 5
Aug 2011

Fixings for stringers shall be in accordance with NZS 3604.

COMMENT:

Separating *decks* from *buildings* reduces the risk of water penetration into the *framing*.

Figure 15: Junction with wall for non-cantilevered timber deck
 Paragraphs 7.1.1, 7.2.2 and Figure 14

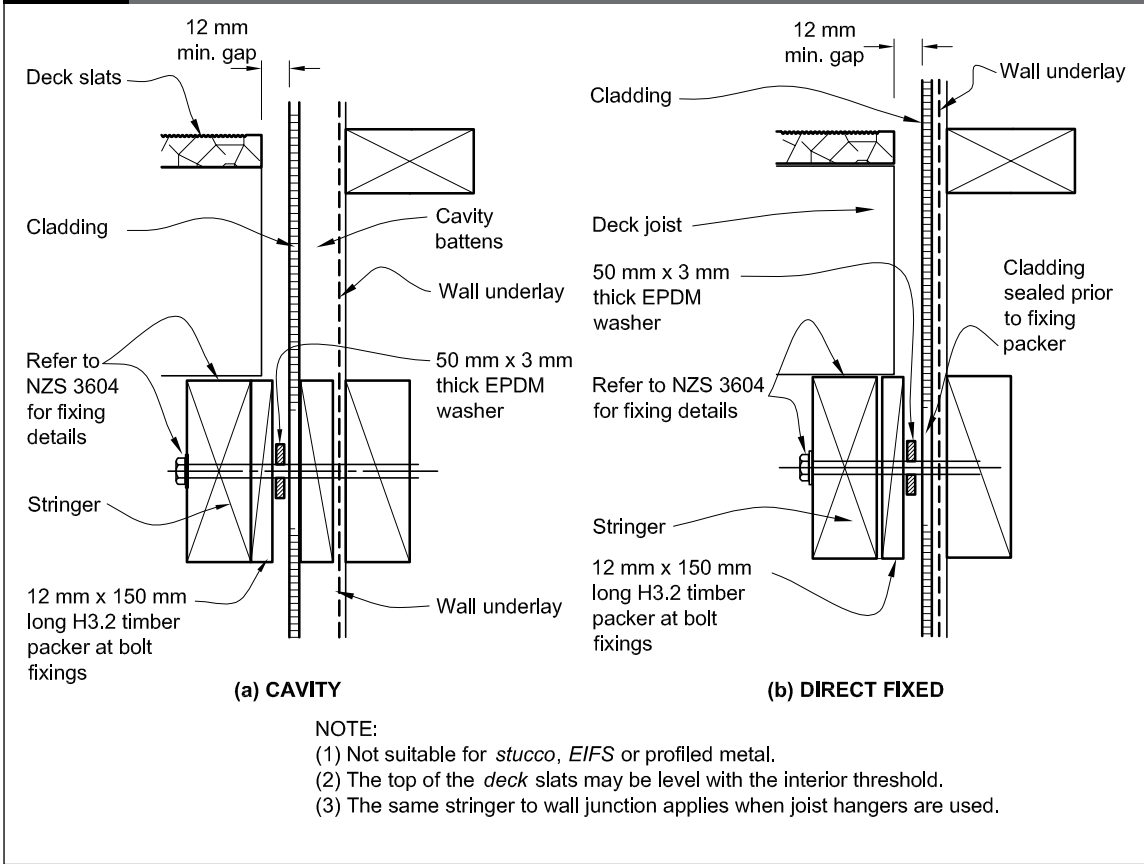

Amend 5
Aug 2011

Wall claddings that rely on surface coatings to reduce water absorption shall be sealed on outer faces and edges prior to fixing the stringers.

Amend 5
Aug 2011

7.2.1.1 Cantilevered decks

Cantilevered decks shall have the junction with the exterior wall made *weathertight* as shown in Figure 16. *Cladding* shall be sealed to the *saddle flashing*.

7.2.2 Pergolas

Connections of other structures, such as pergolas, shall have the junction with the exterior wall made *weathertight* by using the *deck framing* connections shown in Figure 15.

Figure 16: Junction with wall for cantilevered timber deck
Paragraphs 7.1, 7.2.1.1, 7.3.1 and Figure 14

Amend 2
Jul 2005

NOTE:

- (1) *Building wrap* at back of *cavity* shall be taped around joist penetrations.
- (2) The back of the *saddle flashing* shall be positioned behind the cladding.
- (3) Saddle flashing terminates over inter-storey *flashing*.

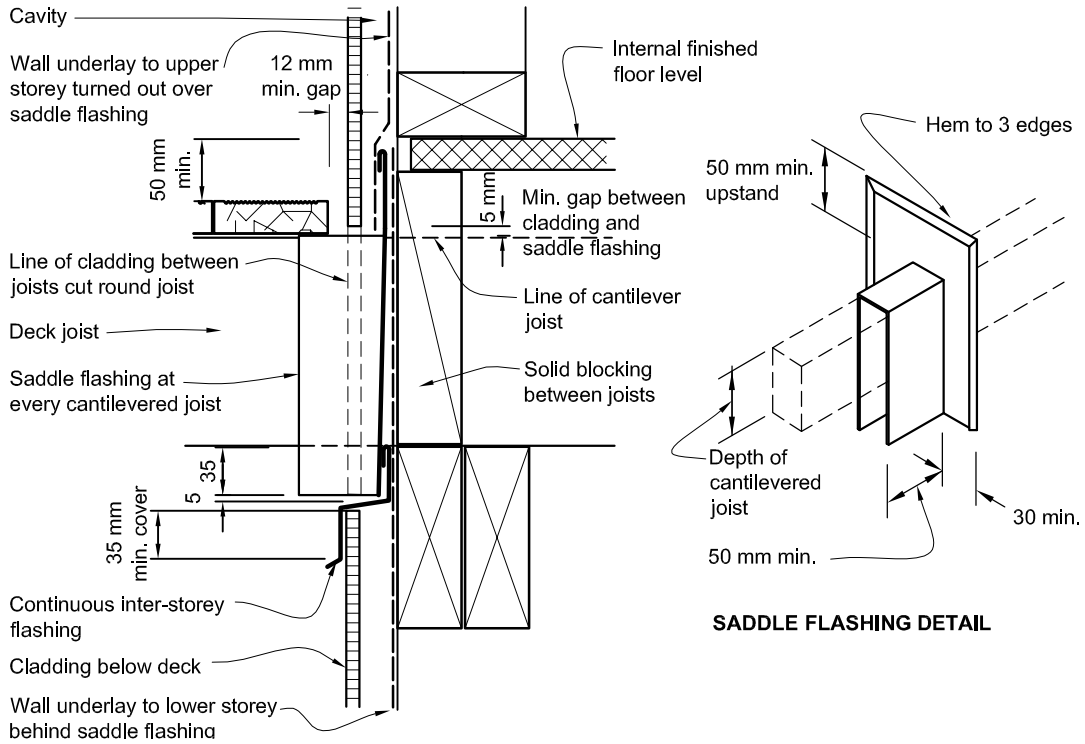

Amend 2
Jul 2005

Amend 5
Aug 2011

7.3 Level thresholds

Where provision for level access is required, this shall be provided as shown in Figure 17A and Figure 17B.

7.3.1 Enclosed decks

Where provision for level access is required for an *enclosed deck*, this shall be provided in Figure 17A. The underlying *membrane deck* surface shall be made *weathertight* as described in Paragraph 8.5.

7.3.1.1 Removable surfaces

Raised removable surfaces of tiles, pavers or timber shall be provided over the underlying *weathertight enclosed deck* surface for cleaning and maintenance, as shown in Figure 17A. A minimum gap of 12 mm shall be provided against the *wall* or balustrade *cladding*.

Amend 5
Aug 2011

7.3.1.2 Timber removable surface

Timber decking shall be over *framing* supported off the *deck membrane* as shown in Figure 17A, with spacing in accordance with B2/AS1.

Amend 5
Aug 2011

No fixings shall penetrate the underlying *deck membrane*.

COMMENT:

Tiled boards or structural pavers sitting on proprietary supports can be adjusted according to level changes in the underlying *deck* surface.

Amend 5
Aug 2011

The pavers or tiled boards are spaced to allow free drainage and the ability to lift the top surface off when necessary.

Amend 5
Aug 2011

The timber option allows access by fixing the timber decking with stainless steel screws, so they may be removed when necessary.

7.3.2 Ground floor level access

Where provision for level access is required, this may be provided as shown in Figure 17B, with exterior paving or decking that complies with the *access route* requirements of D1/AS1.

COMMENT:

The specific features of a *building* and its site can have a significant effect on the options available for providing level access at doors. These features include the provision of shelter, prevailing winds and ground levels. Where level access is required, it is highly recommended that the services of a designer experienced in this field be obtained.

7.3.2.1 Concrete slab

Where provision for level access is required from a concrete floor slab to exterior paving, this shall be as shown in Figure 17B with:

- a) A channel, together with drainage provisions, across the door opening, with:
 - i) the width to suit capacity in accordance with E1/AS1,
 - ii) a minimum depth of 150 mm,
 - iii) a maximum length of 3700 mm, and
 - iv) 1:200 minimum fall along length of channel towards a drainage outlet,
- b) Grating, in accordance with Tables 21 and 22, over the channel, that:
 - i) is supported independently of the door frame,
 - ii) is removable to allow access for cleaning,
 - iii) is specifically designed to accommodate imposed loads,
 - iv) has gaps sized to prevent the wheels of wheel chairs or mobility aids entering or being trapped, and
 - v) has a continuous gap of 12 mm minimum from door frame and *wall cladding*, and

Amend 5
Aug 2011

Amend 5
Aug 2011
Amend 2
Jul 2005

Amend 5
Aug 2011

COMMENT:

The grating support must be specifically detailed to suit the condition of the *building* and site.

- c) Exterior paving that:
 - i) has a minimum fall of 1:40 away from the channel for a minimum distance of 1 m,
 - ii) together with the surrounding paving and ground levels, complies with drainage requirements of E1/AS1.

Amend 5
Aug 2011

7.3.2.2 Timber floor

Where provision for level access is required from a timber floor structure to the exterior, this may be provided as shown in Figure 17B, with clearances in accordance with Paragraph 9.1.3.

Amend 5
Aug 2011

Figure 17A: Level thresholds for enclosed decks
Paragraphs 7.3, 8.5.1 and Figure 17B

NOTE:

- (1) For use for framed, above ground enclosed decks with membrane surfaces.
- (2) Care must be taken to ensure that no fixings or sharp edges penetrate the weathertight membrane deck surface.
- (3) Refer also to Paragraph 8.5.

Errata 2
Dec 2011

Errata 2
Dec 2011

Errata 2
Dec 2011

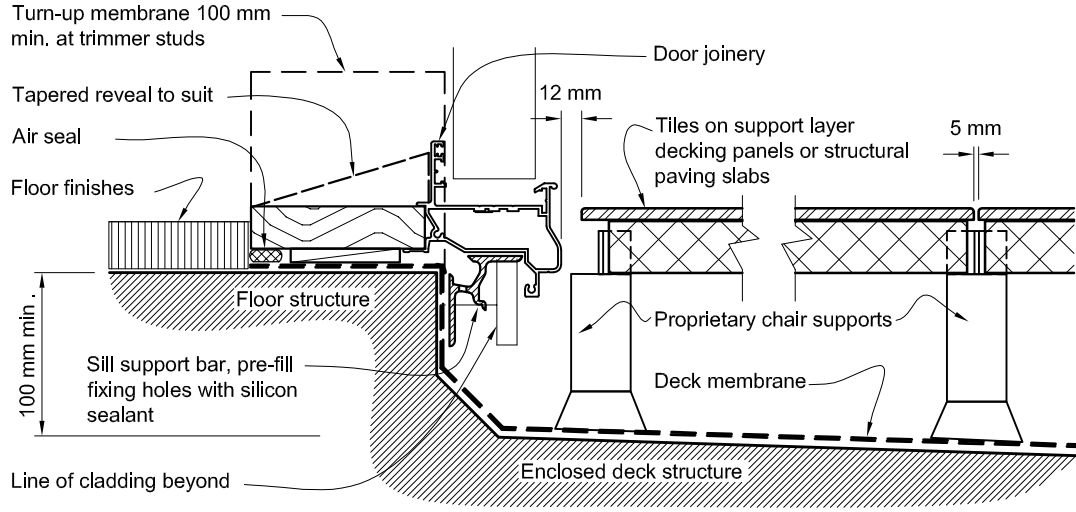

(a) TILE/PAVING

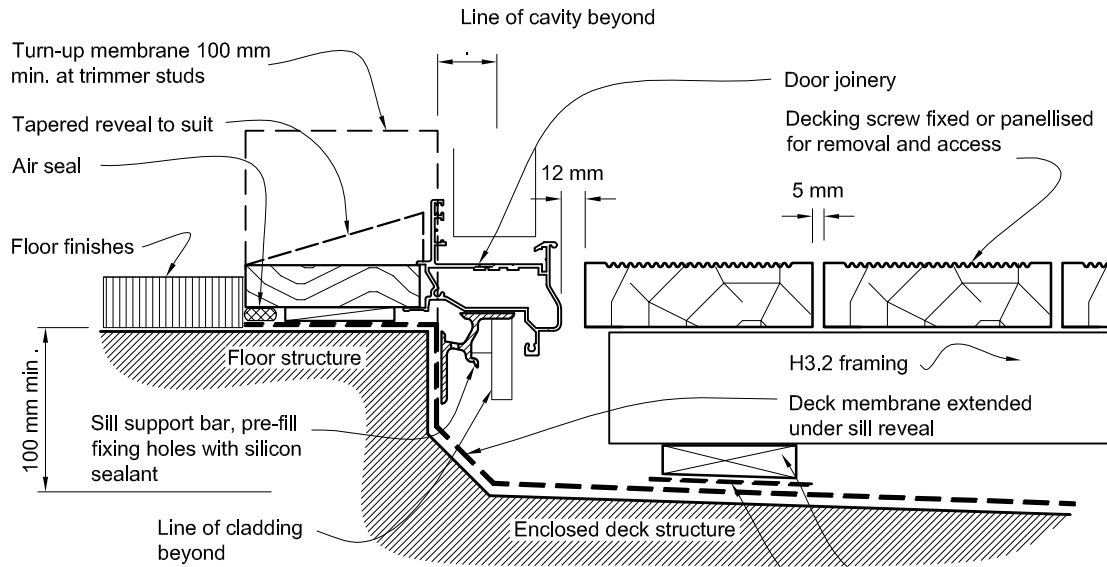

(b) DECKING

Amend 5
Aug 2011

Figure 17B: Level thresholds for ground level
Paragraph 7.3 and Figure 17A

NOTE:

- (1) Detail (a) is suitable for use with concrete floor slabs - refer Paragraph 7.3.2.1 for requirements.
- (2) Detail (b) is suitable for use with timber floors. It may also be adapted for timber decks on upper storeys as per Paragraph 7.1.1 b), or for enclosed decks, with removable panels or decking as shown in Figure 17A.
- (3) Both details may be adapted for inward or outward opening doors.
- (4) Exposure to wind-driven rain must be specifically taken into account when using these details, and shelter to doors and joinery provided where local conditions warrant.

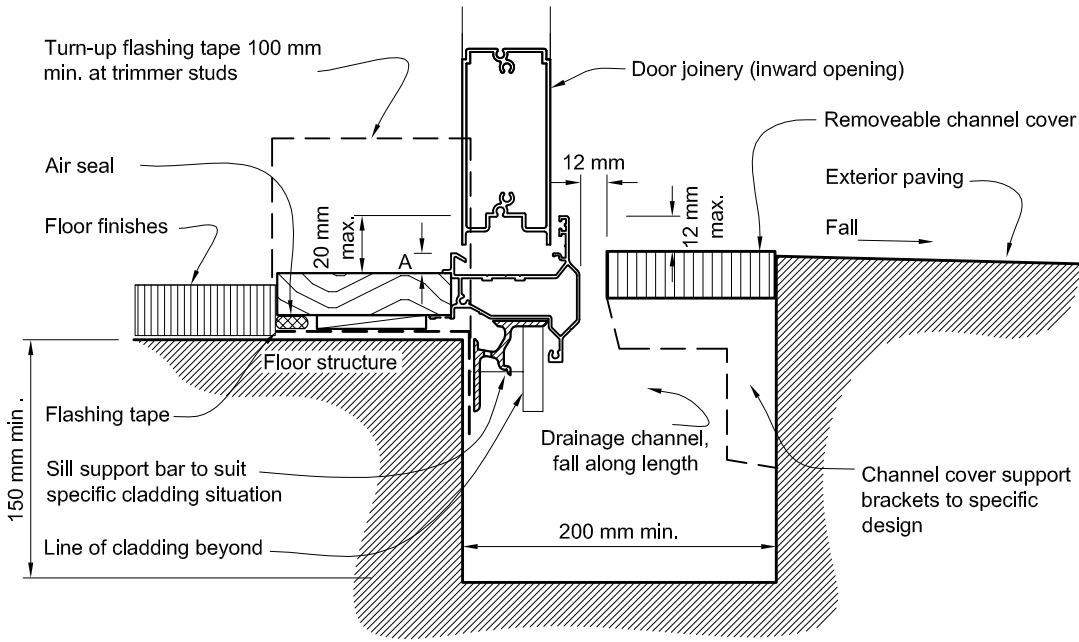

(a) CONCRETE SLAB

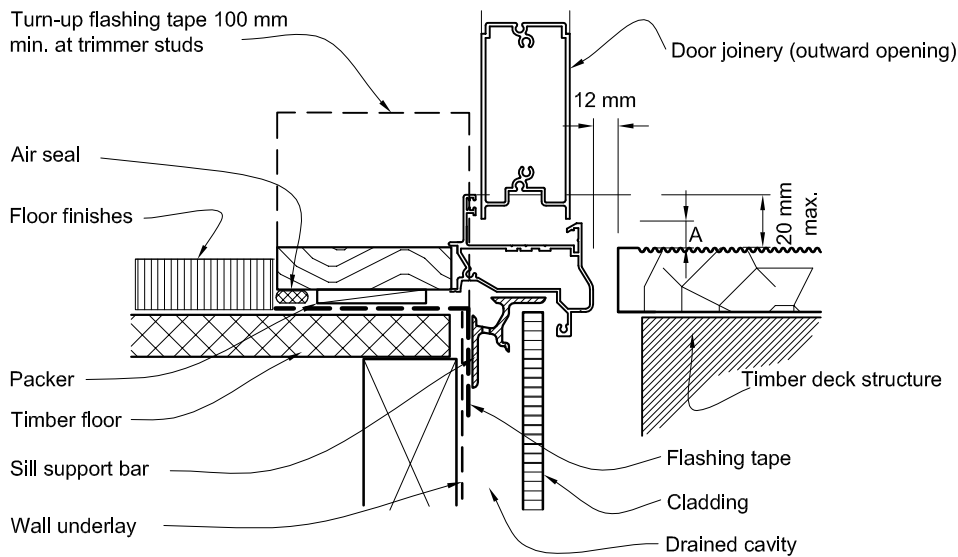

(b) TIMBER FLOOR

NOTE: 'A' to be the minimum dimension to maintain clearance from the bottom of the door to finished floor or deck, to manufacturer's requirements, and to keep sill upstand height to less than 20 mm

Errata 2
Dec 2011

Amend 5
Aug 2011

Figure 17C: Door sills for cavity construction
Paragraph 9.1.10.5, Figures 73C, 85, 86, 91, 99, 116 and 128

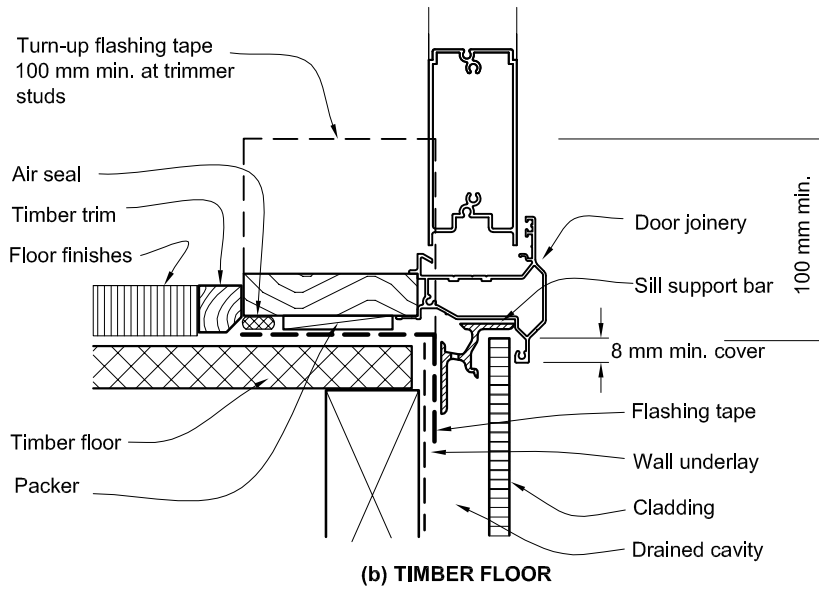
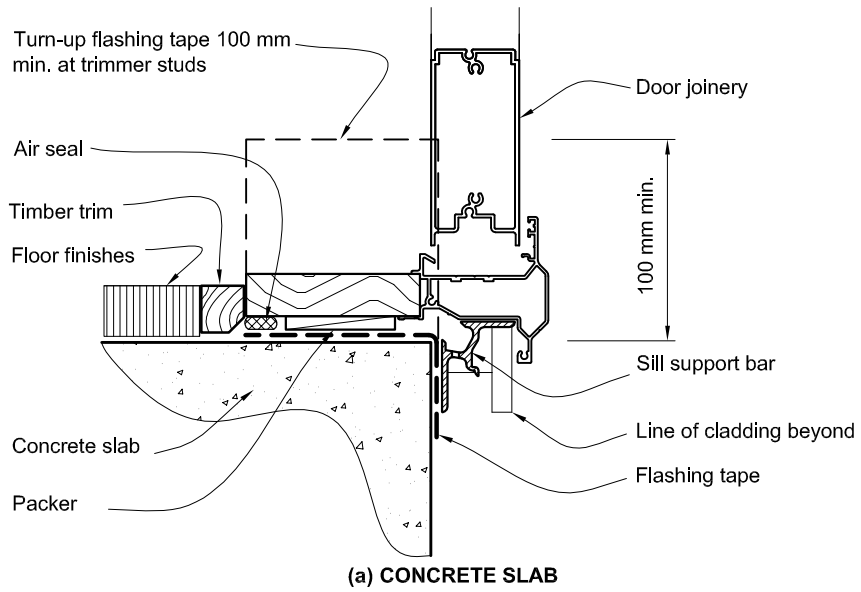

Amend 5
Aug 2011

Figure 17D: Door sills for direct fix
 Paragraph 9.1.10.5, Figures 81, 82, 83, 84, 90, 95 and 115

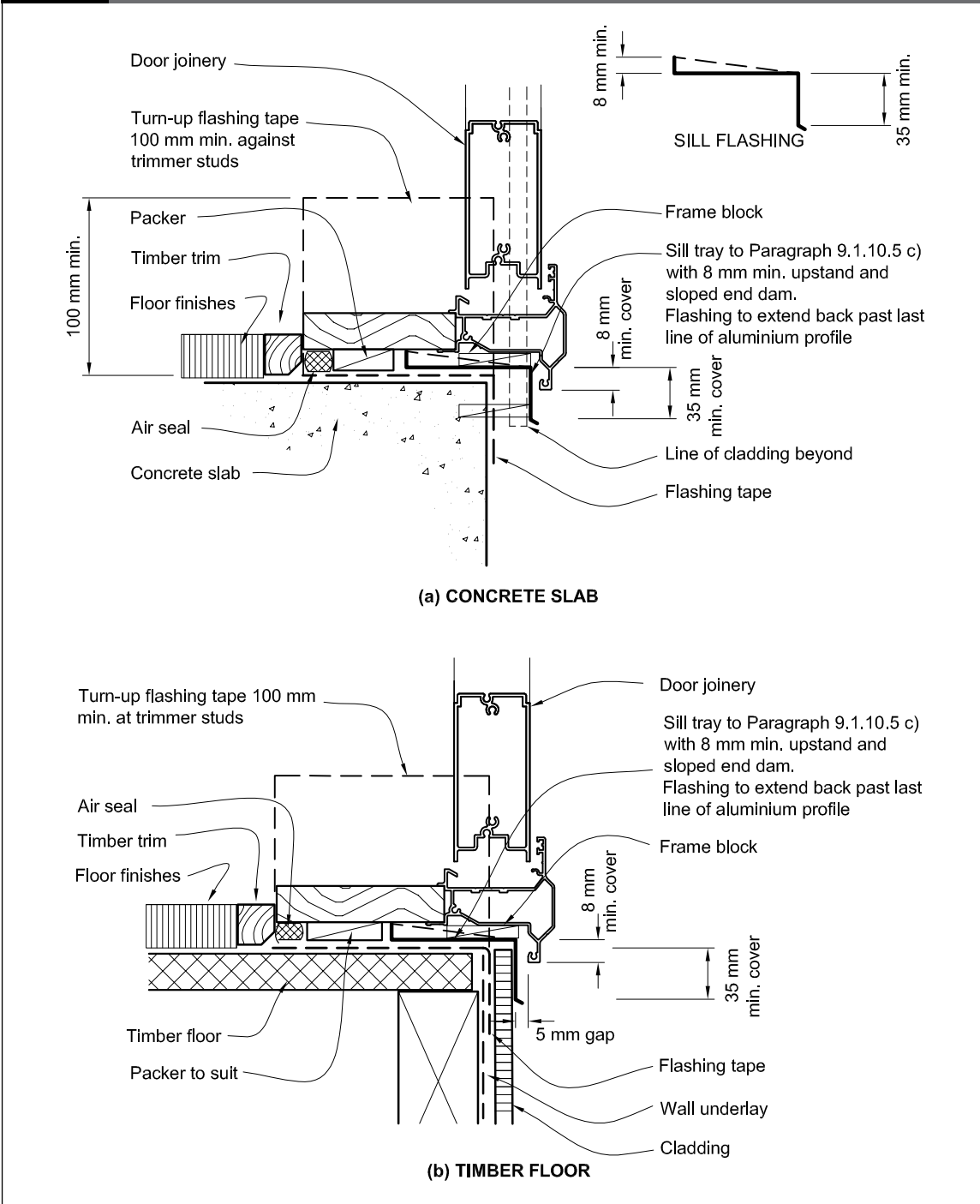

Amend 5
 Aug 2011

7.4 Enclosed balustrades

Enclosed balustrades require a drained cavity for claddings, except for vertical corrugated steel, as outlined in Table 3, and shall be detailed as required for parapets described in Paragraphs 6 and 9.1.8 and Figures 10, 11 and 12. Details for specific cladding systems are given in Paragraph 9.0. Enclosed balustrade cappings for EIFS and flush finished fibre cement may include flush finishes as outlined in Paragraphs 9.7.7 and 9.9.10.

COMMENT:

Reports on leaky buildings show these junctions have been prone to leakage and care must be taken to detail and build them correctly.

7.4.1 Deck drainage

For decks with enclosed balustrades, provision for drainage shall be in accordance with Paragraph 8.5.6 and Paragraph 8.5.10.

7.4.2 Balustrade-to-wall junctions

Enclosed balustrade-to-wall junctions shall be flashed to direct water clear of the outside face of the cladding system using a saddle flashing as shown in Figures 11 and 12.

COMMENT:

Reports on leaky buildings show that these junctions are prone to leakage and care must be taken in detailing and in building them correctly.

7.4.3 Balustrade-to-deck floor junction

The junction of the enclosed balustrade with the floor of the enclosed deck shall be made weathertight as shown in Figure 18.

Junctions with wall claddings shall be as shown in Figure 62.

7.4.4 Metal cappings

Metal cappings to enclosed balustrades shall have dimensions as outlined in Table 7.

Metal cappings shall have the same requirements as outlined for parapets in Paragraph 6.4, with the exception of the:

- a) Slope to the top of the capping, for buildings other than housing to be as in F4/AS1,
- b) Drip edges are required to both sides of the capping. The drip edge to the deck side of the capping shall be a bird's beak as shown in Figure 5.

COMMENT:

A bird's beak drip edge will avoid danger of injury resulting from the sharp edge of a kick-out.

Errata 2
Dec 2011

Amend 5
Aug 2011

Amend 5
Aug 2011

Amend 5
Aug 2011

Figure 18: Enclosed balustrade – bottom of cladding
Paragraphs 7.4.3, 9.1.3, Figures 56, 62, 63 and 64

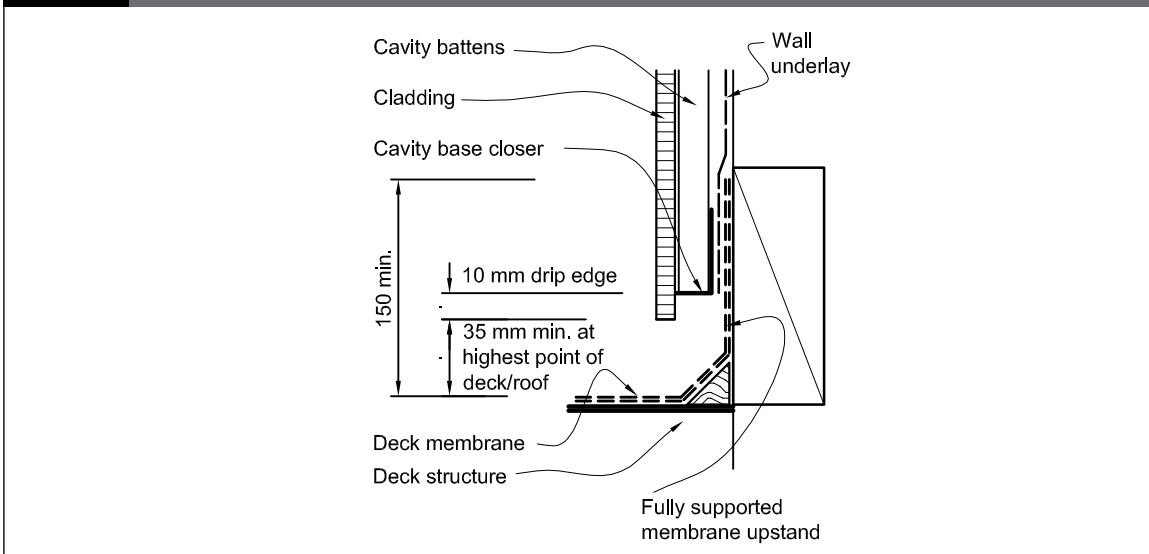

Amend 5
Aug 2011

7.4.5 Stanchions

Amend 5
Aug 2011

Stanchions for handrails, signs, television aerials or similar structures shall be side-fixed through the cladding system into framing, as shown in Figure 19. These fixings are not included for stucco, EIFS or profiled metal in this Acceptable Solution.

Fixing shall be to vertical surfaces only. The sealant shall be compatible with the washer.

Amend 5
Aug 2011

Figure 19: Stanchion fixing
Paragraph 7.4.5

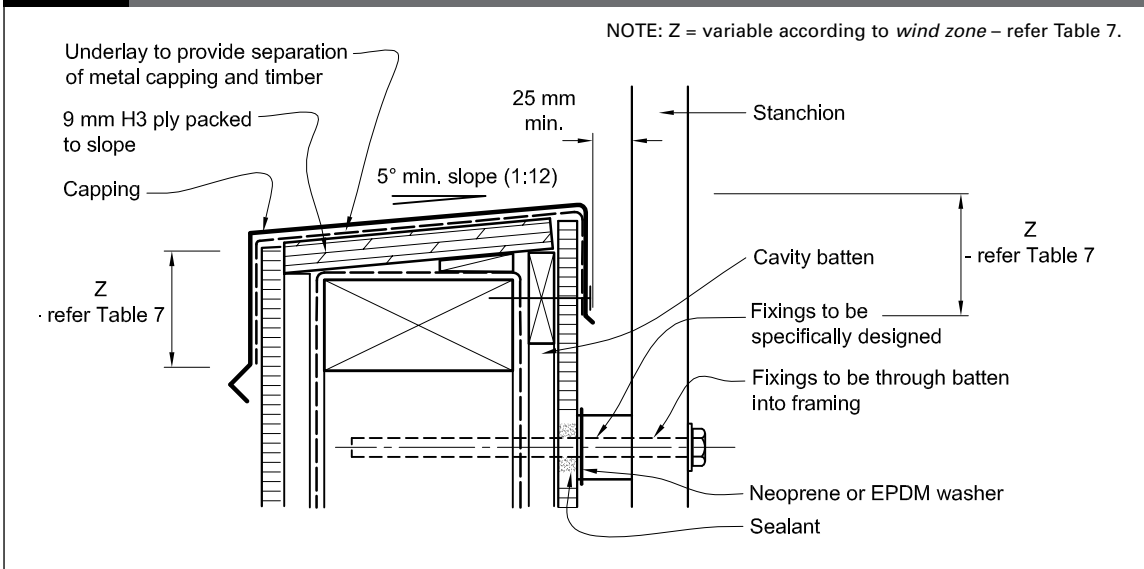

Amend 5
Aug 2011

8.0 Roof Claddings**8.1 General****8.1.1 Weathertightness**

Roof claddings shall meet the requirements of NZBC E2.2, and be specified and *constructed* in accordance with the provisions of Paragraph 8.1.2 to Paragraph 8.5.

COMMENT:

For *roofs* used to collect water for human consumption, refer AS/NZS 4020.

Amend 5
Aug 2011**8.1.2 Limitations**

The following *roof cladding systems* are covered in this Acceptable Solution:

- | | |
|---|----------------|
| a) <i>Masonry tiles</i> | Paragraph 8.2 |
| b) Pressed metal tiles | Paragraph 8.3 |
| c) Profiled metal <i>roof claddings</i> | Paragraph 8.4 |
| d) <i>Membrane</i> roofing | Paragraph 8.5. |

Other *roof claddings* are beyond the scope of this Acceptable Solution.

8.1.3 Maintenance

Maintenance of *claddings* shall be carried out as necessary to achieve the expected *durability* of the materials – refer to Paragraph 2.5.

Amend 5
Aug 2011**COMMENT:**

A deterioration in the appearance of the coating of the metal does not necessarily relate to a deterioration in the *weathertightness* of the *roof cladding*.

Care should be taken to avoid post-installation damage to the *cladding* when accessing the roof. Additional support is required around roof-mounted units such as air-conditioners to avoid roof distortion.

Amend 5
Aug 2011**8.1.3.1 Projecting eaves**

Soffits and verges of all projecting *eaves* shall be closed in. Refer to Paragraph 5.3 for details.

Amend 5
Aug 2011**8.1.4 Fixings**

Fixings shall be as specified in Paragraph 8.2 to Paragraph 8.5.

Materials for fixing *roof claddings* and *flashings*, where necessary, shall be selected from Tables 20, 21 and 22 to minimise corrosion.

Amend 5
Aug 2011**COMMENT:**

The use of stainless steel fixings is not recommended by steel manufacturers for use with coated steel in severe marine and industrial environments, as they are considered to cause deterioration.

Amend 5
Aug 2011Amend 5
Aug 2011**8.1.5 Roof underlays**

Roof underlays shall be to Table 23 and NZS 2295, and be either:

- R1 heavy weight kraft, or
- R2 self supporting kraft.

Underlays shall be:

- Layed with minimum numbers of laps
- Lapped at all side and end laps by minimum 150 mm
- Run horizontally for *roof* pitches below 10°
- Run horizontally or vertically for *roof* pitches above 10°
- Have *anti-ponding boards* at lower edges of masonry tiles, refer Figure 25(b) and Paragraph 8.2.5.

Amend 2
Jul 2005**8.1.5.1 Underlay support**

Prevent sagging of *roof underlay* by either:

- For R1 *underlays*, fully support with a corrosion resistant material
- For R2 self supporting *underlays*, laid to maximum 1.2 metre span between adjacent supports

Amend 5
Aug 2011**COMMENT:**

Solvent in freshly LOSP-treated timber can affect bitumen in *underlays*. Any solvent should be allowed to evaporate before the *roof underlay* is installed.

Amend 5
Aug 2011

8.1.6 Gutters general

Gutters, downpipes and spreaders, including eaves gutters/spoutings are required for the drainage of roof water, and shall:

- a) Be to the minimum dimensions shown in this Acceptable Solution, or calculated to E1/AS1, whichever is the greater
- b) If a gutter depth is reduced to allow entry of a valley gutter, the reduced depth must be used to calculate the capacity of the gutter
- c) For internal, valley, and hidden gutters, have no fixings in gutter bottoms or sides, and be continuously supported on H1.2 minimum treated timber gutter boards or H3 ply which is separated from metal by roof underlay strip.

Eaves gutters/spoutings shall:

- d) Be to any of the materials outlined for flashings in Paragraph 4.1 except 4.3.9, 4.3.10 and 4.3.11
- e) Have a minimum cross sectional area of 2500 mm²
- f) Be designed to overflow water to the outside.

Downpipes shall:

- g) Be formed from any of the materials outlined for flashings in Paragraph 4.1 except 4.3.9, 4.3.10 and 4.3.11
- h) Upper roofs shall drain via downpipes directly to ground level where possible, or
- i) Where discharging to a lower roof, be fitted with a spreader as detailed in Figure 20
- j) Have a maximum catchment area of 25 m² if discharging on to a lower roof area.

Spreader shall:

- k) Be to any of the materials outlined for flashings in Paragraph 4.1 except 4.3.9, 4.3.10 and 4.3.11
- l) Be to Figure 20 and not be used on masonry tile roofs unless a roof underlay is installed
- m) Discharge directed away from roofing laps and clear of roof penetrations.

Amend 5
Aug 2011

COMMENT:

Design calculations for a specific roof may allow larger catchment areas per spreader to be used.

The alternative to a spreader is to direct an upper level downpipe into a rainwater head.

The ends of spreaders should be blocked off where a sideways flow of water is against laps in roof claddings.

Amend 5
Aug 2011

Figure 20: Spreader for roof discharge
Paragraph 8.1.6

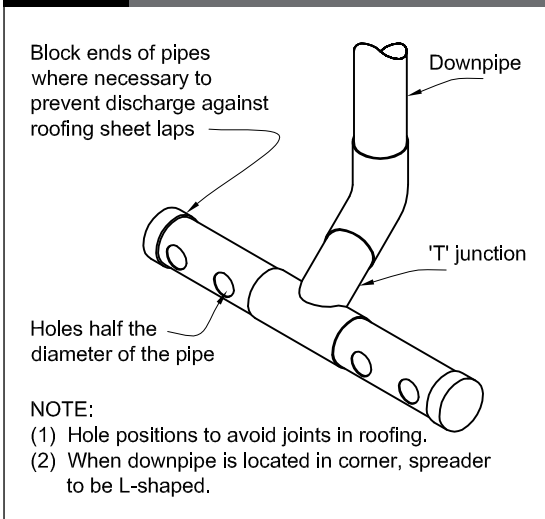

Amend 5
Aug 2011

8.1.6.1 Internal gutters

Internal gutters shall:

- a) Be formed with continuous butyl or EPDM strip complying with Paragraph 4.3.9, with no cross-joints in the gutter, or aluminium, copper, stainless steel, or zinc sheet to Paragraph 4.3, with joints that are welded
- b) Where butyl or EPDM, be minimum 1.5 mm membrane thickness, or 1.0 mm thickness for gutters less than 1 metre wide
- c) Have a minimum slope of 1:100
- d) Be constructed to at least the minimum dimensions shown in Figure 52, or the capacity calculated to E1/AS1 plus an additional freeboard depth of 20 mm minimum.

Amend 5
Aug 2011

For roofs other than *membrane roofs*:

- e) Discharge into a rainwater head as shown in Figure 63 (a) and (b), or
- f) Discharge to an internal outlet to Figure 64 (b) or (c) with overflows provided by either:
 - i) a second outlet to a rainwater head, or
 - ii) an overflow as shown in Figure 63(c), and positioned below the level of any potential overflow into the *building*.

For internal gutters and *membrane roofing*, refer to Paragraph 8.5.

8.1.6.2 Valley gutters and hidden gutters

Valley gutters and *hidden gutters* shall be constructed as shown in Figures 50 and 51 for the applicable *roof cladding* (except for *membrane roofing*) and:

- a) Not change direction in plan
- b) Have a minimum underlap to *roof cladding* as specified in Figures 27, 37, 50, and 51 for the relevant *roof cladding*
- c) Be formed from any of the materials outlined for *flashings* in Paragraph 4.3 except 4.3.10 and 4.3.11
- d) Be fixed at upper ends only, and be secured with a purpose-made clip system for the remaining length to enable expansion/contraction along the length of the gutter
- e) Discharge into an internal gutter or *eaves gutter/spouting*.

In addition:

- f) Have minimum slopes of 8° for *hidden gutters*, and to Table 8 for *valley gutters*
- g) *Hidden gutters* receive no discharge from downpipes or spreaders
- h) Spreaders not discharge directly into a *valley gutter*
- i) *Valley gutters* be minimum 250 mm wide where receiving run off from spreaders.

Amend 5
Aug 2011

Table 8: Maximum catchment areas for valley gutters
Paragraphs 8.1.6.2, 8.4.16.2, 9.7.7.1, 9.9.4.4, 9.9.10.1, Figures 27, 37 and 51

| Gutter width | Maximum catchment area | Minimum roof pitch |
|------------------|------------------------|--------------------|
| 250 mm | 25 m ² | 8° |
| 160 mm to 249 mm | 16 m ² | 12.5° |

NOTE: Catchment areas are limited to:

- (1) Gutters in accordance with Paragraph 8.1.6.2.
- (2) Rainfall intensity with average recurrence interval (ARI) no greater than 200 mm per hour.

Amend 5
Aug 2011

COMMENT:

Gutters for lower-pitched roofs, or for catchment areas other than those shown in Table 8, require *specific design*. Additional information may be found in the New Zealand Metal Roof and Wall Cladding Code of Practice.

Amend 5
Aug 2011

8.1.7 Roof penetrations

Roof penetrations shall be made *weathertight* in accordance with Paragraph 8.2 to Paragraph 8.5.

Where *roof penetrations* are required for large openings such as *roof lights* and *chimneys*, this Acceptable Solution is limited to the following requirements:

- a) The edge of roofing penetrations over 200 mm wide shall be supported in either direction with additional *framing* as shown in Figure 21, and
- b) For the catchment area of the *roof* above the penetration as shown in Figure 22, the *roof* length shall be limited to:
 - i) for profiled metal roofing, Table 17
 - ii) for other *roof claddings*, the areas shown in Table 9.

COMMENT:

Flashings for *roof penetrations* not included in this Acceptable Solution require *specific design*.

For pipe penetrations, refer to details for the *roof cladding* material used.

Amend 5
Aug 2011

Table 9: Maximum catchment areas above penetrations

Paragraph 8.1.7 and Figure 22

| Penetration width | Maximum roof length above penetrations in metres |
|-------------------|--|
| 800 to 1200 mm | 4 m |
| 600 to 800 mm | 6 m |
| 400 to 600 mm | 8 m |
| 0 to 400 mm | 10 m |

NOTE: Refer to Table 17 for profiled metal roofing.

Figure 21: Penetration support

Paragraphs 8.1.7 and 8.4.17

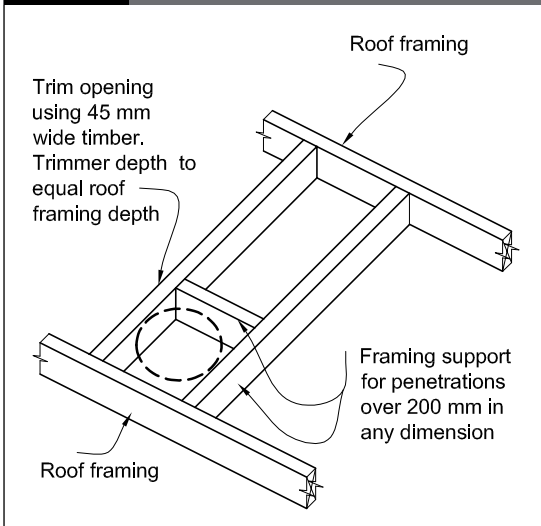

Amend 5
 Aug 2011

Figure 22: Catchment area for penetrations

Paragraphs 8.1.6, 8.1.7, Tables 9 and 17

NOTE:

- (1) Profiled metal roofing - refer Table 17 for maximum roof lengths above penetrations.
- (2) Other roof cladding - refer Table 9 for maximum roof lengths above penetrations.

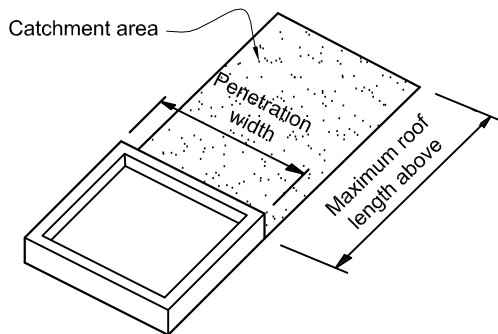

Amend 5
 Aug 2011

8.2 Masonry Tiles

8.2.1 Materials

Concrete tiles shall meet the requirements of NZS 4206 or AS 2049. Clay tiles shall meet the requirements of AS 2049.

8.2.1.1 Tile profiles

For the purposes of this paragraph, tiles shall be divided into three types as listed below:

- a) Type I: Double profile tiles having two distinct watercourses with a minimum watercourse depth of 18 mm,
- b) Type II: Single profile tiles having one watercourse depth of a minimum of 25 mm, or
- c) Type III: Tiles not fitting the Type I or Type II categories, and includes flat tiles and those resembling slates, shakes and shingles.

8.2.2 General

Amend 2
Jul 2005

COMMENT:

Refer to Paragraph 1.5 for qualification of installers.

Amends
2 and 5

8.2.3 Installation

Masonry tile roof cladding shall be installed in accordance with NZS 4206 or AS 2050 onto minimum H1.2 treated timber battens, except the minimum pitch shall be as specified in Table 10. Where required in AS 2050 and Table 20, underlay shall comply with Table 23.

Fixing and fixing patterns shall be to NZS 4206, with the exception that nails shall penetrate a minimum of 35 mm into timber battens, and the minimum pitches and roof underlay shall be as described in Table 10 and Table 23.

Use 304 or 316 stainless steel fixings for corrosion zones B, C, D and E, or hot dip galvanised fixings at 450 g/m² for Zone B and Zone C. Refer to Table 20 for corrosion zones.

Amend 5
Aug 2011

Table 10: Minimum pitches for masonry tiles
Paragraph 8.2.3, Figure 25

| Tile material | Profile type | With underlay (1)(2) | Without underlay (1)(2) |
|--|--------------|----------------------|-------------------------|
| Concrete tiles (to rafter length 4.5 m) | Type I | 15° | 20° |
| | Type II | 20° | – |
| | Type III | 25° | – |
| Clay tiles (to rafter length 4.5 m) | Type I | 20° | 25° |
| | Type II | 20° | – |
| | Type III | 25° | – |

NOTE: (1) Increase pitch by 1° per additional 0.5 metres of rafter length over 4.5 m.
(2) Roof underlay is required for any roof receiving discharge from a spreader, or for roofs in wind zone Very High or Extra High.

Amend 2
Jul 2005

Amend 2
Jul 2005

Amend 5
Aug 2011

COMMENT:

Rafter length, tile profile and wind zone all affect the allowable minimum pitch of a tile roof. Rafters longer than in Table 10 may require the addition of underlay.

Manufacturers may have specific profiles that are suitable for pitches lower than those shown in Table 10, but these are outside the scope of this Acceptable Solution.

Amend 5
Aug 2011

Where masonry tiles have been shown to comply with the dynamic weathertightness test requirements of AS 4046: Part 9, a lower pitch may be used providing it is not less than 15°.

8.2.4 Flashings and fixings

Materials for flashings, gutters and fixings shall be in accordance with Paragraph 4.0, and:

- a) Be selected from Table 20 to minimise corrosion, and
- b) Be compatible with mortar and bedding in accordance with Table 21 and Table 22.

8.2.5 Anti-ponding boards

Masonry tile roofs with underlays shall have anti-ponding boards installed to Figure 25. Where anti-ponding boards are used, these shall be set to a minimum fall of 5° (1:12), and shall be treated minimum H1.2 for solid timber and H3 for plywood.

Amend 5
Aug 2011

Amend 5
Aug 2011

8.2.6 Details and flashings

Hips, ridges, valleys and barges shall be made weathertight by using flashings and seals as shown in Figure 23 to Figure 28.

Figure 23: Masonry tile ridge
Paragraph 8.2.6

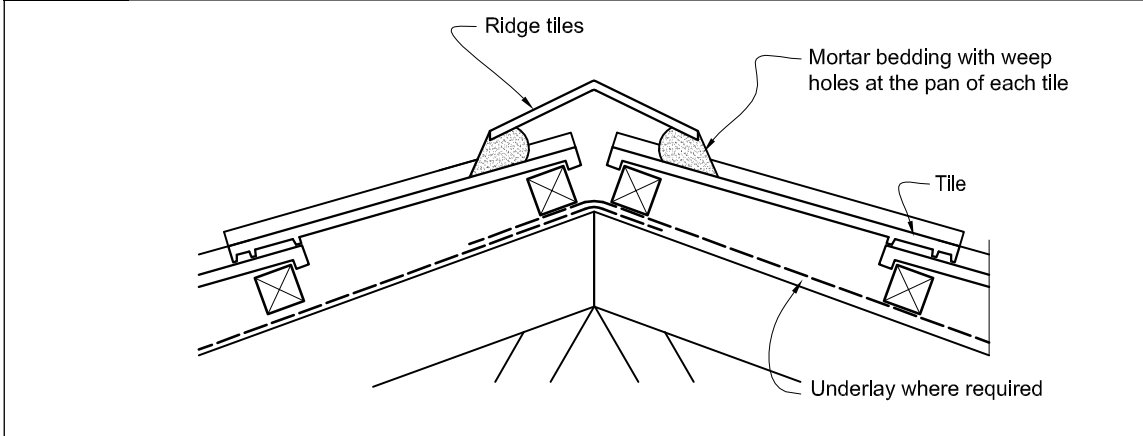

Amend 5
Aug 2011

Amend 2
Jul 2005

Figure 24: Barge for masonry tile
Paragraph 8.2.6

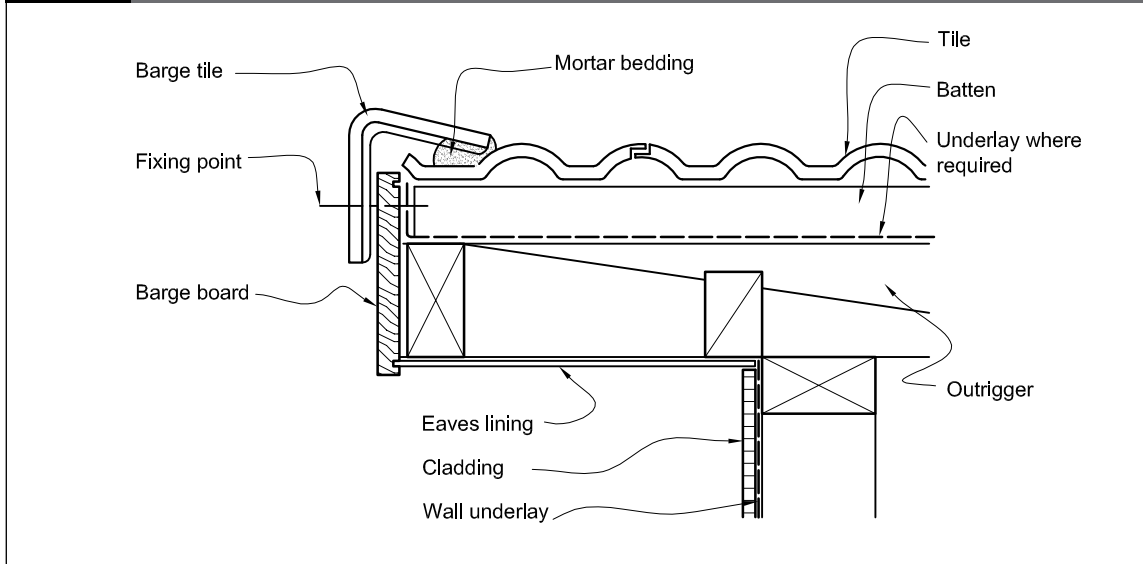

Amend 2
Jul 2005

Amend 2
Jul 2005

Amend 5
Aug 2011

Amend 2
Jul 2005

Figure 25: Timber fascia eaves for masonry tile
Paragraphs 8.1.5 and 8.2.5

NOTE: (1) *Anti-ponding boards* required for tile roofs with underlays.
(2) Refer Table 10 for tile types and roof pitches requiring *roof underlays*.

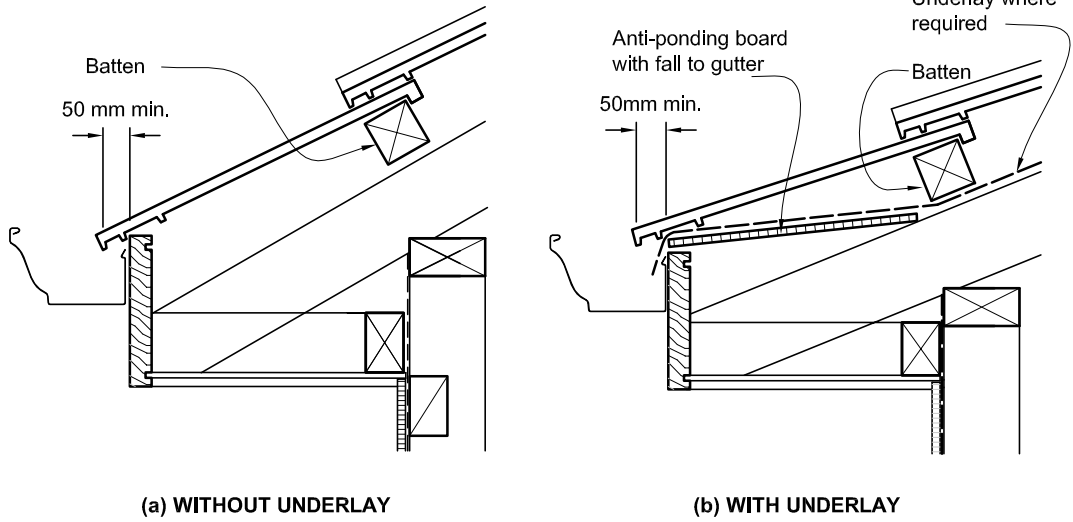

Amend 5
Aug 2011

Figure 26: Apron details for masonry tile
Paragraph 8.2.6

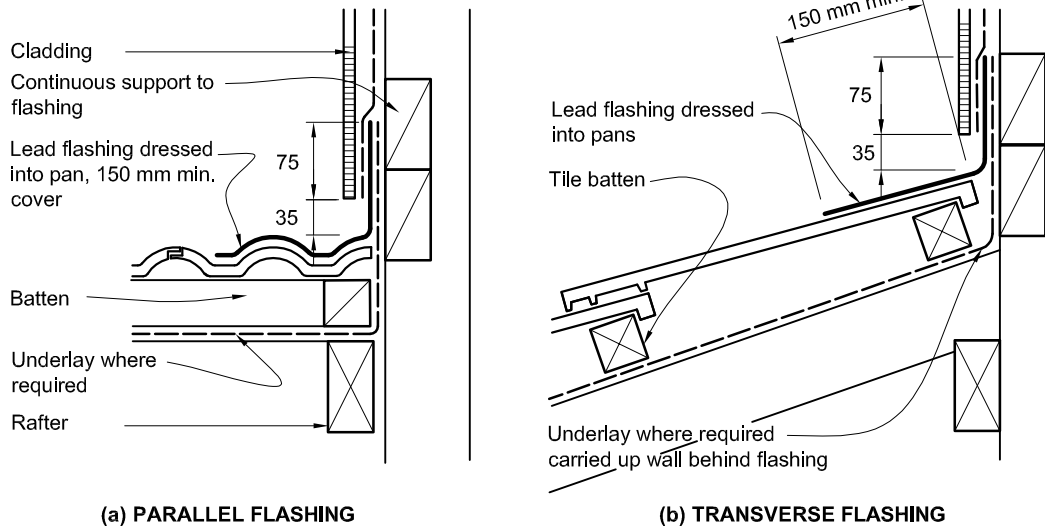

Amend 2
Jul 2005

Amend 5
Aug 2011

Figure 27: Valley for masonry tile
Paragraphs 8.2.6 and 8.1.6.2

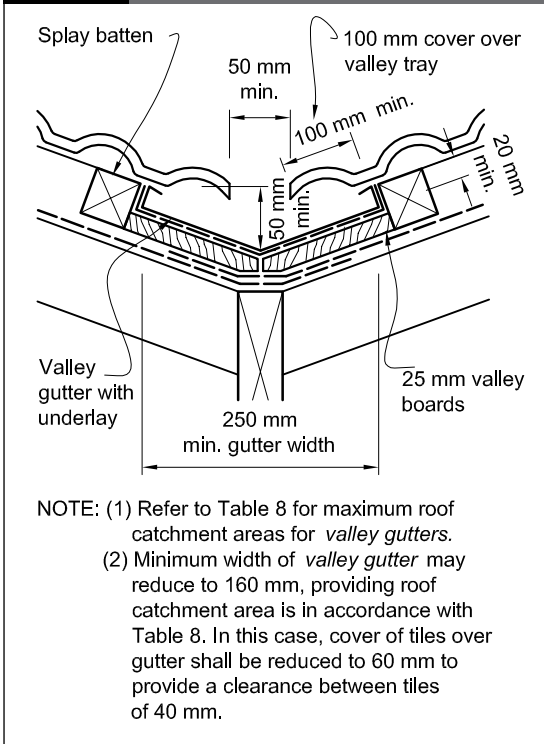

Amend 2
Jul 2005

Amend 5
Aug 2011

Figure 28: Roof/wall ridge for masonry tile
Paragraph 8.2.6

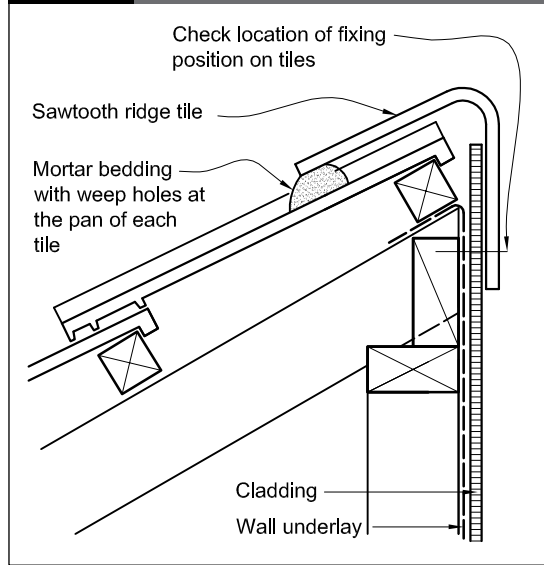

Amend 2
Jul 2005

Amend 5
Aug 2011

8.2.7 Penetrations

Penetrations shall be flashed as shown in Figure 29 to Figure 31.

Amend 5
Aug 2011

Holes in tiles for pipe penetrations shall be machine-cut to minimise the size of the hole.

Figure 29: Pipe penetration for masonry tile
Paragraph 8.2.7

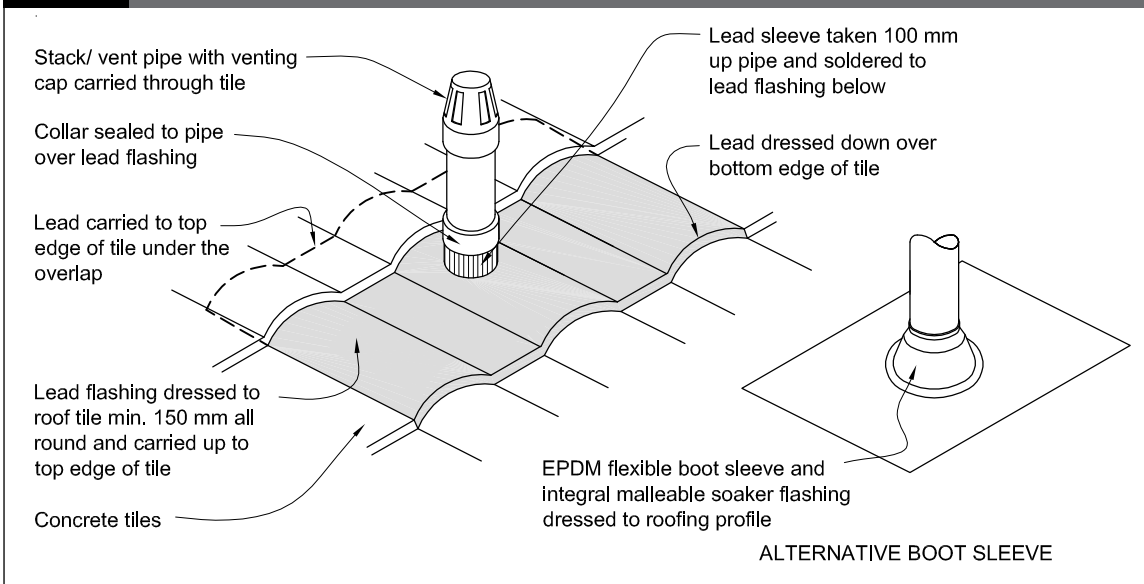

Amend 2
Jul 2005

Amend 5
Aug 2011

Figure 30: Abutment at framed penetration for masonry tile
Paragraph 8.2.7, Table 9 and Figure 31

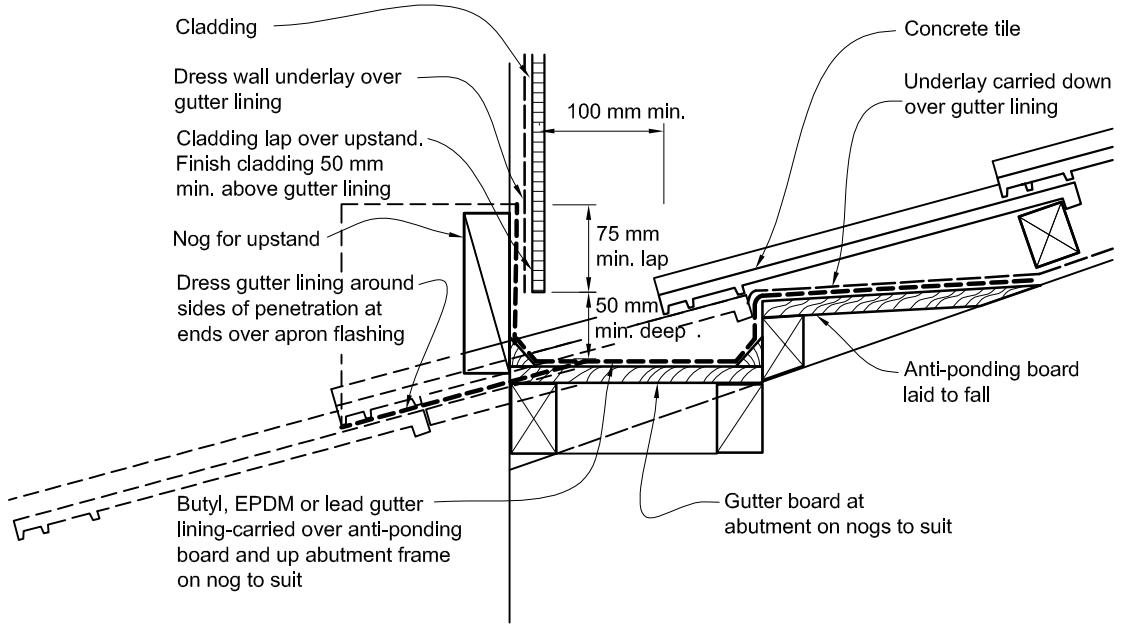

Amend 2
Jul 2005

Amend 5
Aug 2011

Figure 31: Flashing to framed penetration for masonry tile
Paragraph 8.2.7, Table 9 and Figure 30

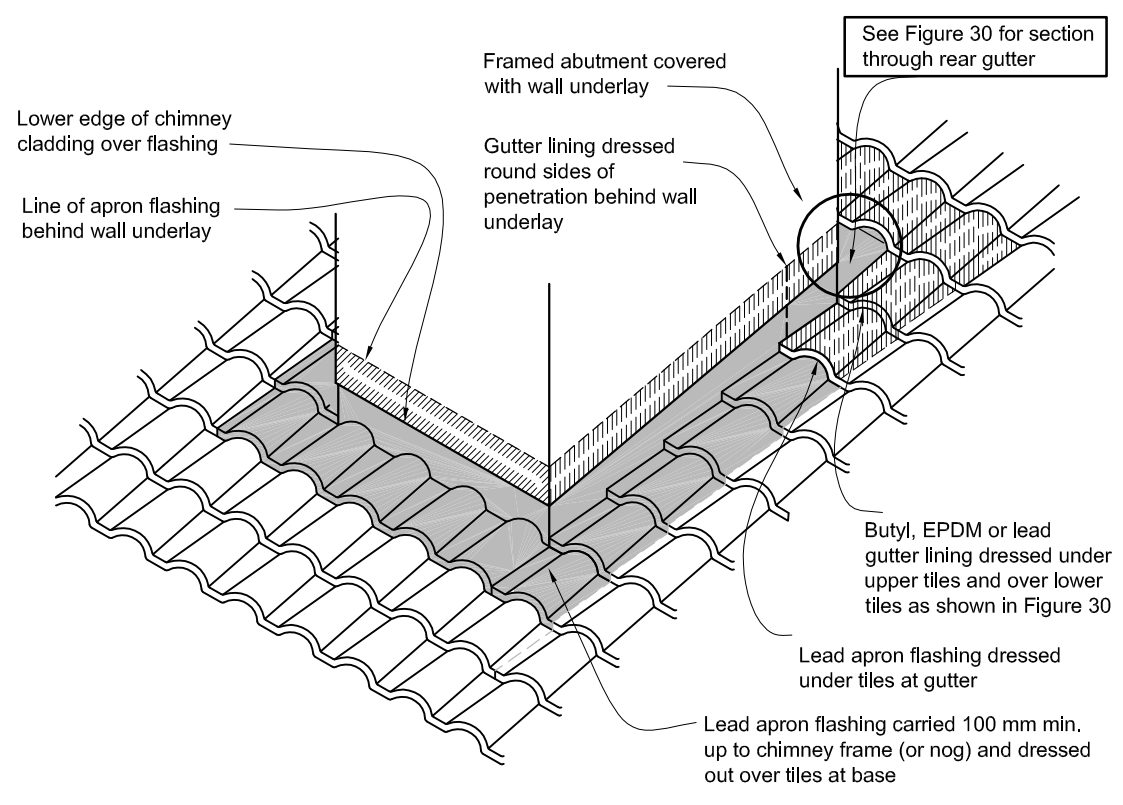

Amend 5
Aug 2011

8.3 Pressed Metal Tiles

8.3.1 Limitations

This Acceptable Solution is limited to pressed metal tile roofs.

Amend 5
Aug 2011
Amend 2
Jul 2005

COMMENT:

Additional guidance on pressed metal tiles can be found in the New Zealand Metal Roof and Wall Cladding Code of Practice.

8.3.2 Installation

Amend 2
Jul 2005

COMMENT:

Refer to Paragraph 1.5 for qualification of installers.

Amends
2 and 5

8.3.3 Tiles and accessories

Tiles and their accessories shall meet the requirements of NZS 4217.

Amend 5
Aug 2011

8.3.4 Metal substrate

8.3.4.1 Choice of metal

COMMENT:

The exposure zone in which a building is located can affect the durability of flashings.

Exposure zones are defined in NZS 3604, based on the likely exposure to wind-driven sea-salt. Corrosion due to geothermal or corrosive industrial atmospheres, as defined in NZS 3604, require specific design.

Exposure zones are based on AS/NZS 2728. AS/NZS 2728 lists atmospheric classes derived from ISO 9223 for Australia and New Zealand.

Amend 5
Aug 2011

8.3.4.2 Steel

Steel for the manufacture of pressed metal tile and flashing systems shall:

- a) have a base metal thickness (BMT) of 0.39 mm minimum,
- b) be grade G300,

Amend 5
Aug 2011

- c) be selected for corrosion protection according to the intended exposure zone as shown in Table 20.

Amend 2
Jul 2005

Paint coatings may include factory-applied finishes complying with AS/NZS 2728, or factory-painted or bonded resin and chip finishes of minimum 15 year durability.

Amend 5
Aug 2011

8.3.4.3 Aluminium

Aluminium for the manufacture of pressed metal tiles and flashing systems shall comply with AS/NZS 1734, and shall:

Amend 5
Aug 2011

- a) Have a base metal thickness (BMT) of 0.7 mm minimum,
- b) Be minimum 5000 series,
- c) For pre-painted aluminium, have a factory-applied finish complying with AS/NZS 2728.

Amend 2
Jul 2005

8.3.5 Roof pitch

General approximations of profile types for standard profile and shake or shingle profile metal roof tiles are shown in Figure 32.

Amend 5
Aug 2011

The minimum roof pitches for metal tiles where rafter length does not exceed 12 m shall be limited to:

Amend 2
Jul 2005

- a) 12° (1:4.75) for profiles resembling standard profiles, and
- b) 15° (1:3.75) for profiles resembling shingle or shake profiles.

Amend 5
Aug 2011

Where rafter length exceeds 12 m, increase minimum pitch by 1° per additional 0.5 m.

Amend 2
Jul 2005

Figure 32: Metal tile profiles
Paragraph 8.3.5

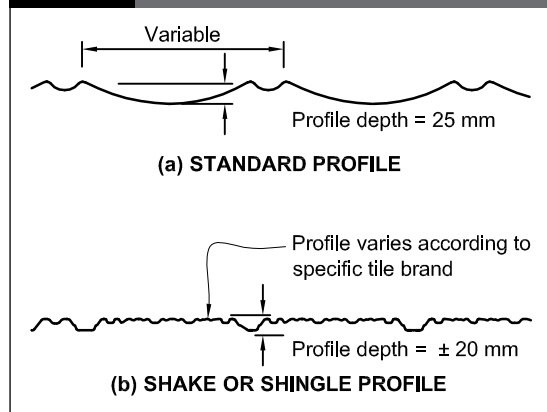

Amend 5
Aug 2011

Amend 5
Aug 2011

COMMENT:

Panels are available in a wide range of profiles.

Where manufacturers have more stringent requirements, these should be followed to optimise performance and to avoid invalidating guarantees.

8.3.6 Underlay

Amend 5
Aug 2011

All metal tile roofing shall have a *roof underlay* installed. *Roof underlay* shall be to Table 23. Refer to Paragraph 8.1.5 for installation details.

Amend 5
Aug 2011

If LOSP-treated timber is used, *roof underlay* shall not be applied until the LOSP solvent has been allowed to evaporate.

COMMENT:

Solvent in freshly LOSP-treated timber can affect bitumen in *underlays*. Any solvent should be allowed to evaporate before the *roof underlay* is installed.

Amend 5
Aug 2011

8.3.7 Fixings

Pressed metal tiles shall be fixed as shown in Figure 33, with:

a) 50 x 2.8 mm hot-dipped galvanized painted flat-head annular-grooved nails. For fixings through the top of the tiles, use neoprene washers containing no more than 15% by weight carbon black content, with

Amend 2
Jul 2005

- b) Four fixings per sheet through:
 - i) the turn-down of the tiles for the body of the roof, and
 - ii) the top of the profile slope for sheets at the *eaves*, avoiding the weather channel of the tiles.

8.3.8 Flashings

The *roof* shall be flashed at all boundaries, except at the discharge to a gutter, using the details shown in Figure 34 to Figure 37.

Metal *flashings* are generally supplied by the metal tile manufacturer, and shall comply with Paragraph 8.3.4.2 and Table 7, unless specifically shown otherwise in the details.

Amend 5
Aug 2011

COMMENT:

Metal tile manufacturers supply pre-folded or formed accessories and recommendations for their installation.

Amend 5
Aug 2011

Figure 33: Metal tile fixings
Paragraph 8.3.7

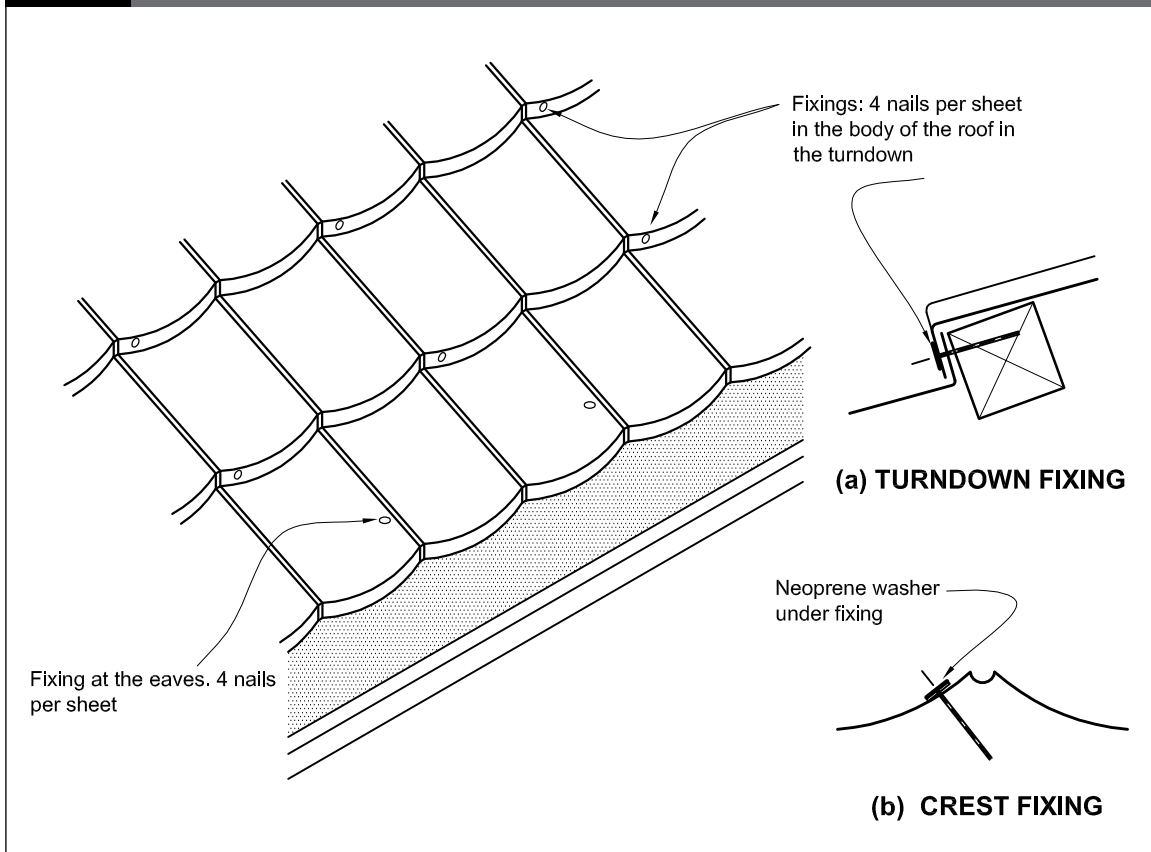

Amend 2
Jul 2005

Amend 5
Aug 2011

Figure 34: Ridge or hip flashings for metal tile
Paragraphs 8.3.3 and 8.3.8

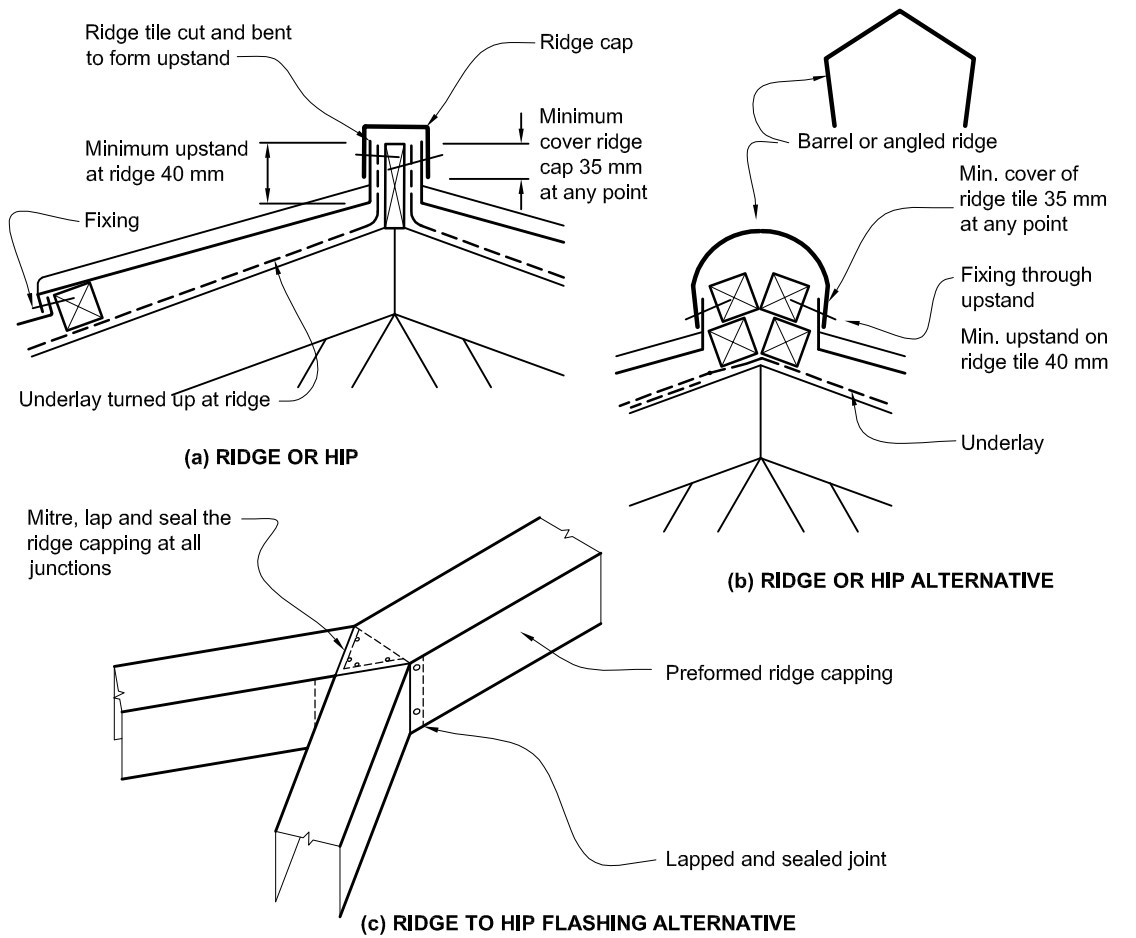

NOTE: For alternative ridge profiles, ridge to hip capping must be preformed to suit profile.

Amend 2 Jul 2005

Amend 2 Jul 2005

Amend 5 Aug 2011

Figure 35: Apron flashings for metal tile
Paragraphs 8.3.3 and 8.3.8

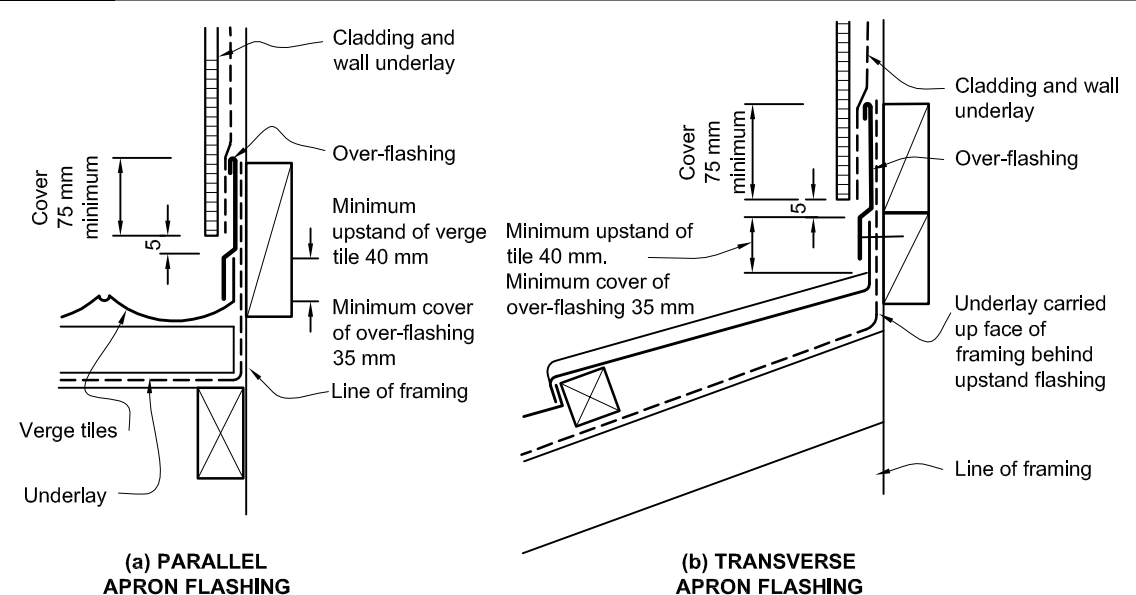

(a) PARALLEL APRON FLASHING

(b) TRANSVERSE APRON FLASHING

Amend 5 Aug 2011

Figure 36: Eaves and barge for metal tile
Paragraphs 8.3.3 and 8.3.8

NOTE: If alternative barge *flashing* profiles are used, these profiles must achieve equivalent covers.

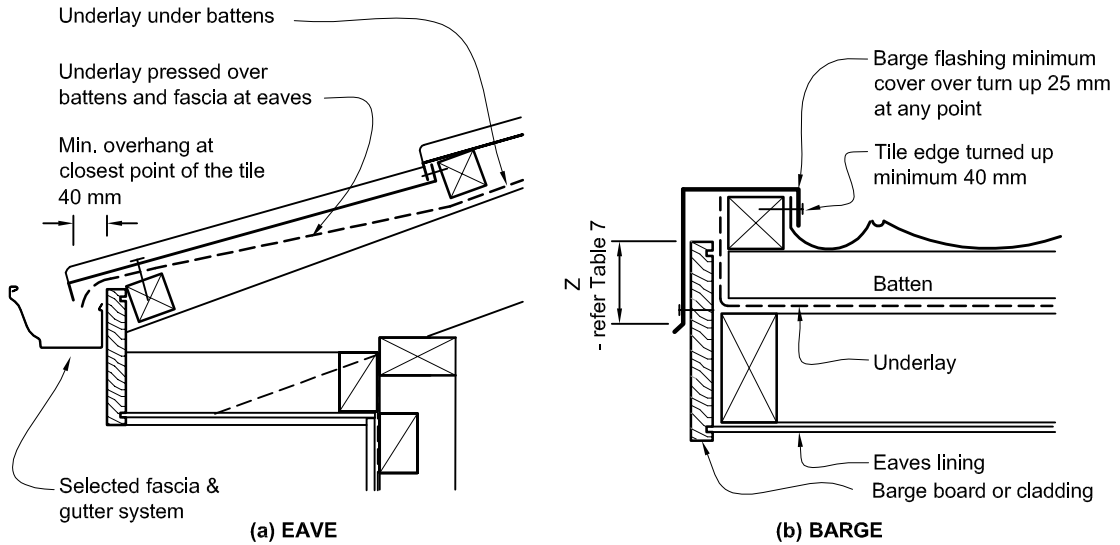

Amend 5
Aug 2011

Amend 2
Jul 2005

Figure 37: Hidden and valley gutter flashings for metal tile
Paragraphs 8.1.6.2, 8.3.3, 8.3.8, Figure 51

NOTE: (1) Refer to Table 8 for maximum catchment areas for *valley gutters*.
(2) Minimum width of *valley gutter* may reduce to 160 mm, providing roof catchment area is in accordance with Table 8. In this case, minimum dimensions as shown, shall apply.

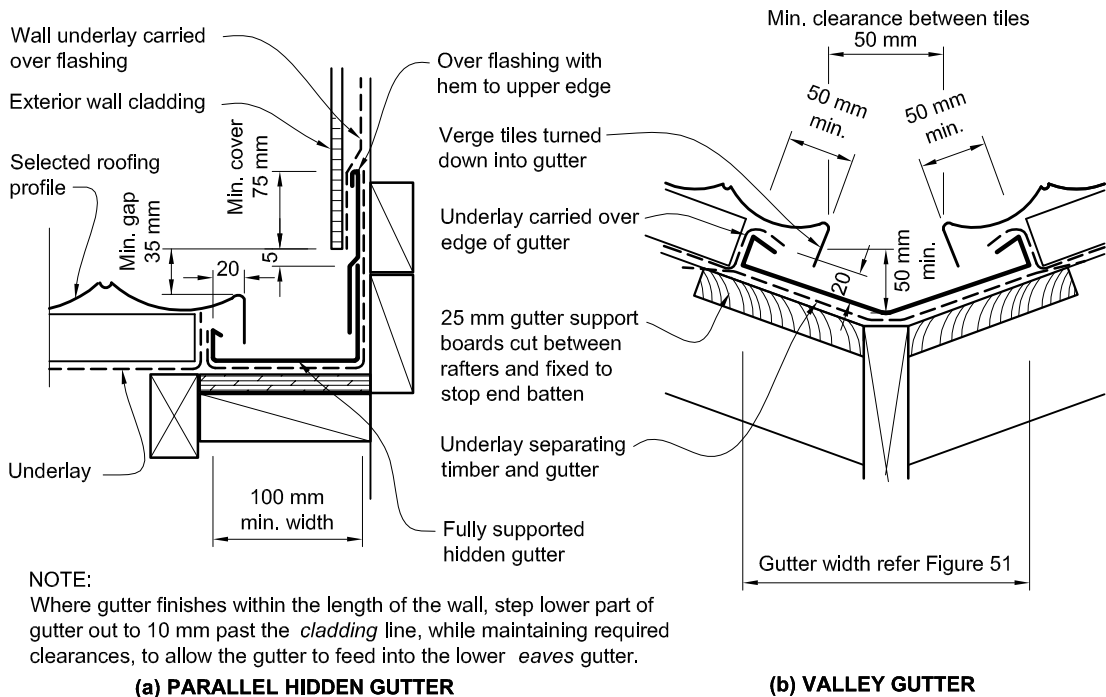

NOTE:
Where gutter finishes within the length of the wall, step lower part of gutter out to 10 mm past the *cladding* line, while maintaining required clearances, to allow the gutter to feed into the lower *eaves* gutter.

Amend 2
Jul 2005

Amend 5
Aug 2011

8.3.9 Gutters, ridges, barges and fascias

Gutters, ridges, barges and fascias shall be as shown in Figures 34–37.

Refer to Paragraph 5.2 for termination of *roofs* against *wall claddings*.

Amend 5
Aug 2011

8.3.10 Roof penetrations

Pipe penetrations shall be flashed using *EPDM flashings* similar to that shown for masonry tiles, Figure 29.

Amend 5
Aug 2011

COMMENT:

Use purpose-made preformed rooflights and ventilators supplied by the manufacturer of the tiles where available.

Amend 2
Jul 2005

8.4 Profiled Metal Roof Cladding

8.4.1 Limitations

This Acceptable Solution is limited to the following types of profiled metal *roof cladding*:

- a) Profiled as outlined in Paragraph 8.4.4,
- b) *Valley gutters* that do not change direction in plan,
- c) Not curved, and
- d) With sheets no more than 18 metres long.

Amend 5
Aug 2011

Amend 2
Jul 2005

COMMENT:

If curved profiled metal sheet is used, the radius of the curve may affect *durability*. *Specific design* is required, and manufacturers and the New Zealand Metal Roof and Wall Cladding Code of Practice should be consulted for recommendations.

8.4.2 General

Amend 2
Jul 2005

COMMENT:

Refer to Paragraph 1.5 for qualification of installers.

Amends
2 and 5

8.4.3 Materials

8.4.3.1 Choice of metal

Metal roof *cladding* and *flashings* shall be selected according to the exposure conditions in Table 20 as defined in:

- a) NZS 3604, or
- b) AS/NZS 2728.

Amend 2
Jul 2005

Amend 5
Aug 2011

Amend 5
Aug 2011

COMMENT:

The exposure zone in which a *building* is located can affect the *durability* of *flashings*.

Exposure zones are defined in NZS 3604, based on the likely exposure to wind-driven sea-salt. Corrosion due to geothermal or corrosive industrial atmospheres, as defined in NZS 3604, require *specific design*.

Exposure zones are based on AS/NZS 2728. AS/NZS 2728 lists atmospheric classes derived from ISO 9223 for Australia and New Zealand.

Amend 5
Aug 2011

8.4.3.2 Steel

Materials for the manufacture of profiled steel *roof cladding* shall:

- a) have a *BMT* of 0.4 mm minimum
- b) be grade G550, or G300 for rolled, crimped, or trough profile roofing
- c) be selected for corrosion protection according to the intended exposure zone as shown in Table 20.

Amend 5
Aug 2011

Amend 2
Jul 2005

Amend 2
Jul 2005

Amend 2
Jul 2005

Amend 2
Jul 2005

8.4.3.3 Aluminium

Aluminium for the manufacture of profiled aluminium roofing shall comply with AS/NZS 1734, and be a minimum:

- a) *Base metal thickness (BMT)* of 0.7 mm,
- b) 5000 series.

Pre-painted aluminium roofing shall have a factory-applied finish complying with AS/NZS 2728.

Amend 5
Aug 2011

Amend 2
Jul 2005

COMMENT:

A deterioration in the appearance of the coating of the metal does not necessarily relate to a deterioration in the *weathertightness* of the *roof cladding*.

8.4.4 Profiles

Profiles covered in this Acceptable Solution are shown in Figure 38, and consist of:

Amends 2 and 5

a) **Corrugated** – curved with a crest height of 16.5 mm minimum,

Amend 5 Aug 2011

b) **Trapezoidal** – symmetrical or asymmetrical with a minimum crest height of 19 mm, and for asymmetrical a flat or lightly profiled pan width of 210 mm maximum between crests, and

Amend 5 Aug 2011

c) **Trough profile** – with vertical ribs at a minimum height of 38 mm, and flat or lightly profiled pans of 210 mm maximum between crests.

8.4.5 Roof pitch

For roofs up to 18 metres in length without end laps, pitches shall be:

Amend 2 Jul 2005

a) Corrugated – not less than 8° (1:7).

b) *Trapezoidal* – not less than:
i) 4° (1:14) where the crest height is less than 27 mm, or
ii) 3° (1:20) where the crest height is 27 mm or higher.

Amend 5 Aug 2011

c) *Trough profile* – not less than 3° (1:20).

COMMENT:

For roofs over 18 metres in length refer to the manufacturer for minimum pitch requirements. Where manufacturers have more stringent requirements, these should be followed to optimise performance and to avoid invalidating guarantees.

Amend 2 Jul 2005

Figure 38: Profiled metal profiles
Paragraphs 8.4.4, 9.6.1, 9.6.5 and Table 3

NOTE: Tables 11 to 13 have limited profile requirements for given roofing spans.

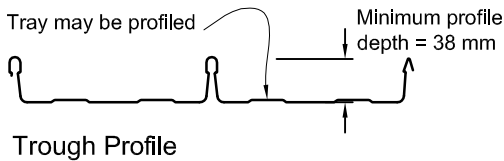
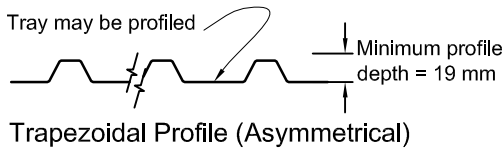
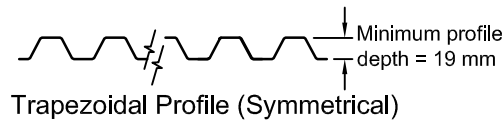
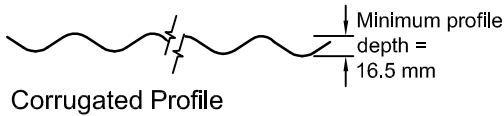

Amend 2 Jul 2005

Amend 2 Jul 2005

Amend 5 Aug 2011

8.4.6 Structure

The maximum span and fixing patterns of profiled metal roof cladding between purlins to comply with this Acceptable Solution are given in Table 11, Table 12 or Table 13, 14 and 15. Spans shown are for steel with BMT, grade and profile as specified in each Table.

Amend 5 Aug 2011

Amend 2 Jul 2005

COMMENT:

For purlin sizes, spacing and fixing, refer to NZS 3604. Additional support will be required around roof-mounted services such as air-conditioning in order to avoid roof distortion.

Amend 2 Jul 2005

Amend 5 Aug 2011

Amends 2 and 5

Table 11: Steel corrugate profiled roofing – 0.4 mm BMT and minimum profile height 16.5 mm
Maximum spans and fixing patterns. Refer to Paragraph 8.4.6

| Purlin spacings (metres) | | Wind zones | | |
|--------------------------|-------------------|----------------|--------------------|------------|
| End span | Intermediate span | Low and Medium | High and Very High | Extra High |
| 0.4 | 0.6 | C2 | C2 | C2 |
| 0.6 | 0.9 | C2 | C2 | C1 |
| 0.8 | 1.2 | C2 | C1 | C1 |

NOTE: C1 fixing pattern is – Hit 1, miss 1...
C2 fixing pattern is – Hit 1, miss 1, hit 1, miss 2...

Amend 5
Aug 2011

Table 12: Steel corrugate profiled roofing – 0.55 mm BMT with minimum profile height 16.5 mm
Maximum spans and fixing patterns. Refer to Paragraph 8.4.6

| Purlin spacings (metres) | | Wind zones | | |
|--------------------------|-------------------|----------------|--------------------|------------|
| End span | Intermediate span | Low and Medium | High and Very High | Extra High |
| 0.4 | 0.6 | C3 | C3 | C3 |
| 0.6 | 0.9 | C3 | C3 | C3 |
| 0.8 | 1.2 | C3 | C3 | C3 |
| 1.15 | 1.6 | C3 | C3 | C2 |

NOTE: C2 fixing pattern is – Hit 1, miss 1, hit 1, miss 2...
C3 fixing pattern is – Hit 1, miss 2, hit 1, miss 3...

Amend 5
Aug 2011

Table 13: Steel trough profile roofing – 0.55 mm BMT with profile height 46 mm minimum, and pan width 210 mm maximum(2)
Maximum spans. Refer to Paragraph 8.4.6

| All building wind zones | |
|----------------------------------|-------------------|
| Maximum span of roof cladding mm | |
| End span | Intermediate span |
| 1100 | 1600 |

NOTE: (1) Trough profile with 0.4 mm BMT steel is excluded from this Acceptable Solution
(2) For profile heights and pan widths outside this range, refer to supplier's literature for fixing patterns and spans

Amend 5
Aug 2011

Amend 2
Jul 2005

COMMENT:

It is recommended that access to the roof is limited to within 100 mm of purlin lines to avoid damaging the roof cladding.

Amend 2
Jul 2005

8.4.7 Underlay

All profiled metal long-run roofing shall have a roof underlay installed to Table 23. See Paragraph 8.1.5 for installation details.

Amend 5
Aug 2011

8.4.8 Fixings: corrugated and trapezoidal

Fixings shall be as shown in Tables 11, 12, 14 and 15, and shall be a minimum 12-gauge screw, as shown in Figure 39, which complies with Class 4 of AS 3566: Part 2.

Amend 2
Jul 2005

Amend 2
Jul 2005

COMMENT:

Screw fixing is recommended for metal roofing as there is less likelihood of the fixing 'backing out' than with a nail.

Amend 5
Aug 2011

Amend 2
Jul 2005

The spacing requirements for fixings are conservative, and a specific design may produce a more optimum spacing, especially with the use of load-spreading washers. Consult roofing manufacturers for information.

8.4.8.1 Fixing requirements

Fixings shall:

Amend 2
Jul 2005

Amend 5
Aug 2011

- a) Be fixed through crests,
- b) Penetrate purlins by a minimum of 40 mm for nail fixings and 30 mm for screw fixings,
- c) Include sealing washers of:
 - i) neoprene (having a carbon black content of 15% or less by weight),
 - ii) profiled washer and EPDM washer where required to allow for expansion of the profiled metal roof cladding.

Amends
2 and 5

Amend 2
Jul 2005

Figure 39: Corrugated and trapezoidal fixings and sheet lap
Paragraphs 8.4.8, 9.6.6, Tables 20, 22 and 24

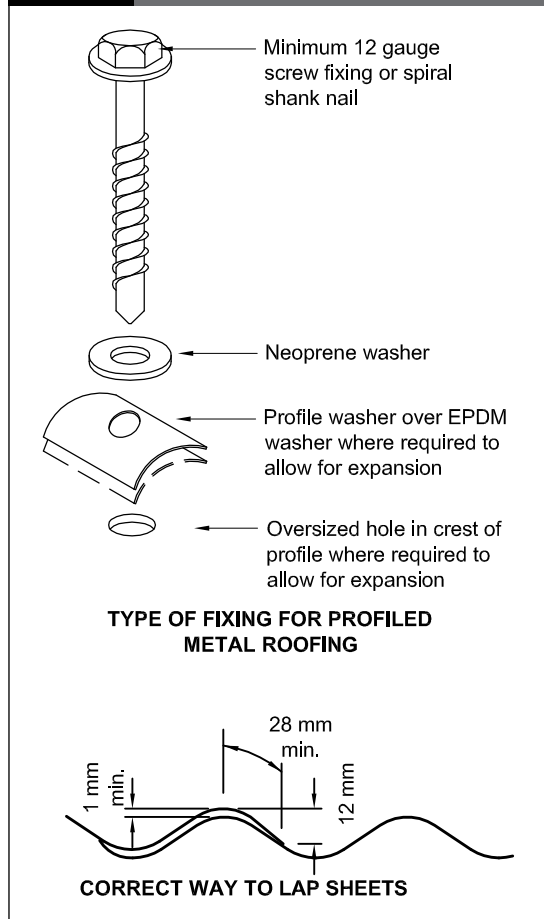

Amend 2
Jul 2005

Amend 5
Aug 2011

Table 14: Steel trapezoidal profiled roofing – 0.4 mm BMT and profile height 27 mm minimum(1), and minimum 5-rib profiles
Maximum spans and fixing patterns. Refer to Paragraph 8.4.6

| Purlin spacings (metres) | | Wind zones | | |
|--------------------------|-------------------|----------------|--------------------|------------|
| End span | Intermediate span | Low and Medium | High and Very High | Extra High |
| 0.4 | 0.6 | T2 | T2 | T1 |
| 0.6 | 0.9 | T2 | T1 | T1 |
| 0.8 | 1.2 | T2 | T1 | T1 |
| 1.2 | 1.8 | SED | SED | SED |

NOTE: T1 fixing pattern is – Fix every crest...
 T2 fixing pattern is – Hit 1, miss 1...
 SED Specific Engineering Design
 (1) For profile heights and pan widths outside this range, refer to supplier's literature for fixing patterns and spans

Amend 5
Aug 2011

Table 15: Steel trapezoidal profiled roofing – 0.55 mm BMT, profile height 27 mm minimum(1) and minimum 5-rib profiles
Maximum spans and fixing patterns. Refer to Paragraph 8.4.6

| Purlin spacings (metres) | | Wind zones | | |
|--------------------------|-------------------|----------------|--------------------|------------|
| End span | Intermediate span | Low and Medium | High and Very High | Extra High |
| 0.4 | 0.6 | T2 | T2 | T2 |
| 0.6 | 0.9 | T2 | T2 | T2 |
| 0.8 | 1.2 | T2 | T2 | T2 |
| 1.2 | 1.8 | T2 | T1 | T1 |

NOTE: T1 fixing pattern is – Fix every crest...
 T2 fixing pattern is – Hit 1, miss 1...
 (1) For profile heights and pan widths outside this range, refer to supplier's literature for fixing patterns and spans

Amend 5
Aug 2011

Amend 2
Jul 2005

Amend 5
Aug 2011

8.4.9 Fixings: trough profile

Clip fixings for *trough profiles* and spans as shown in Table 13 shall be as shown in Figure 40, and shall:

Amend 2
Jul 2005

Amend 2
Jul 2005

Amend 5
Aug 2011

- a) Have a minimum *BMT* of 0.9 mm
- b) Be a minimum width of 30 mm
- c) Be made from a material compatible with the *cladding*, refer to Tables 20 and 21
- d) Have clips fastened with a minimum of two 10-gauge by 30 mm waferhead hot-dipped galvanised screws which comply with Class 3 of AS 3566: Part 2.

Amend 2
Jul 2005

Figure 40: Typical trough profile fixings
Paragraph 8.4.9

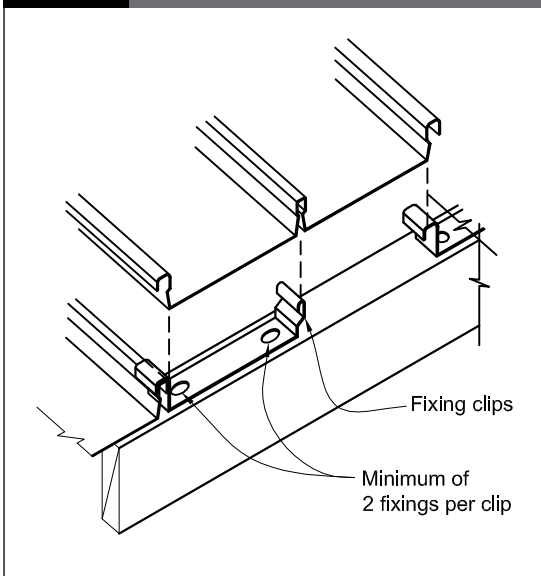

Amend 2
Jul 2005

Amend 5
Aug 2011

Amends
2 and 5

8.4.10 Allowance for expansion

Allowance shall be made for expansion of corrugated and *trapezoidal roof cladding* as shown in Table 16.

Where Table 16 requires profiled washers, allowance shall be made for expansion by:

Amend 5
Aug 2011

- a) Fixing the top 50% (closest to the ridge) with conventional fixings, and
- b) Fixing the lower 50% with sealing washers fixed over profiled washers as shown in Figure 39, and:
 - i) using oversized holes, and
 - ii) positioning fixing in centre of hole.

Amend 5
Aug 2011

Table 16: Expansion provisions
Paragraph 8.4.10, Figure 39

| Material | < 8 m | 8-12 m | 12-18 m | >18 m |
|-----------|-----------------|------------------|------------------|-------|
| Steel | NSR | Profiled washers | Profiled washers | SD |
| Aluminium | Oversized holes | Profiled washers | SD | SD |

SD – Requires *specific design*
NSR – No special requirements

Amend 5
Aug 2011

Amend 5
Aug 2011

Amend 2
Jul 2005

8.4.11 Flashing requirements

The roofing shall be flashed at all boundaries to comply with the following:

- a) At edges discharging to gutters with *eaves flashings* where required in Figure 45(a)
- b) *Soft edge* to cover *flashings* complying with Paragraph 4.6. Refer to Figure 41 for example of use and Tables 21 and 22.
- c) Notched turn-downs to cover *flashings* shall comply with Paragraph 4.6. Refer to Figure 42 for example of use.
- d) Materials for *flashings* shall be compatible with the *roof cladding* material as per Table 21 and Table 22, and shall be in accordance with Paragraph 4.3.
- e) Provide *expansion joints* in accordance with Paragraph 4.5.2.

Amend 2
Jul 2005

Amend 2
Jul 2005
Amend 5
Aug 2011

Amend 2
Jul 2005

8.4.11.1 Fixing flashings

- a) When fixing *flashings* to the structure, use screws as for roofing (see Paragraph 8.4.8).

- b) When fixing *flashings* to other *flashings* or to roofing use:
- i) for galvanized steel, 4 mm diameter monel metal or stainless steel rivets, where compatible as per Table 21,
 - ii) for aluminium-zinc coated steel, 4 mm diameter aluminium rivets,
 - iii) for aluminium, 4 mm diameter aluminium rivets.

Amend 2
Jul 2005

COMMENT:

The use of stainless steel fixings is not recommended by steel manufacturers for use with coated steel, in severe marine and industrial environments, as they are considered to cause deterioration.

Amend 5
Aug 2011

- c) *Flashing* joints, including *expansion joints* where required, shall be in accordance with Paragraph 4.5.2 and as shown in Figure 6.
- d) Where end-laps are required in *flashings*, form these as shown in Figure 6 and, before joining the two parts, apply an 8 mm diameter bead of neutral cure sealant complying with:
- i) Type F, Class 20LM or 25LM of ISO 11600, or
 - ii) low modulus Type II Class A of Federal Specification TT-S-00230C.

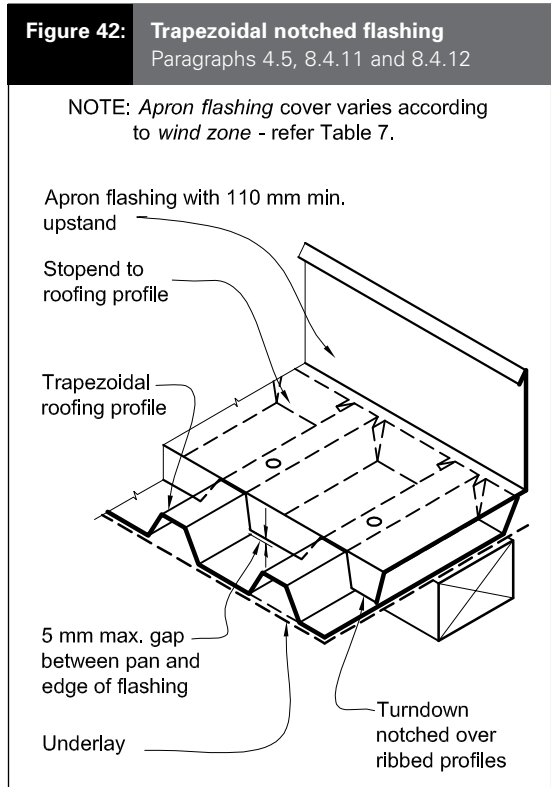
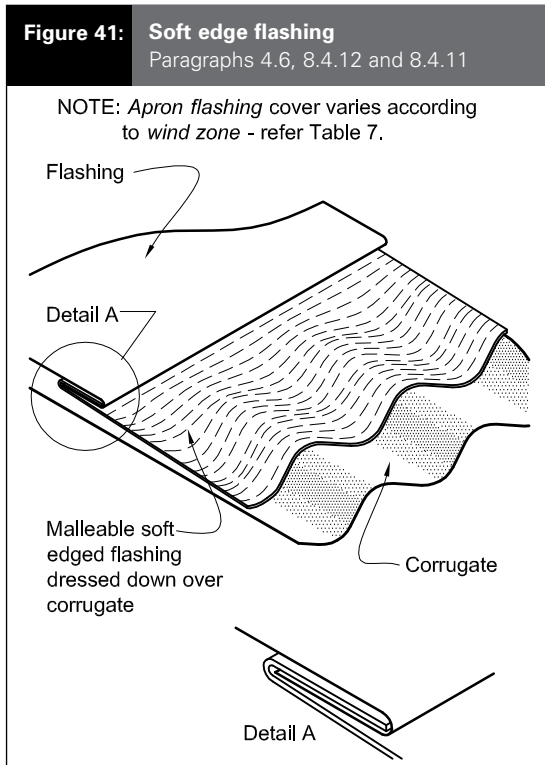

8.4.12 Flashing details

The *roof* shall be flashed using details shown below:

Amend 2
Jul 2005

Amend 5
Aug 2011

- a) Ridge to hip as shown in Figure 43,
- b) *Apron flashing* and change in pitch as shown in Figure 44,
- c) *Eaves* and roof/wall ridge as shown in Figure 45,
- d) *Eaves flashing* as in Figure 45(a) required for all roofs under 10° pitch and soffit widths less than 100 mm,
- e) Ridge and hip as shown in Figure 46,
- f) *Barge flashings* as shown in Figure 47,
- g) *Apron flashing – parallel flashing* to profile as shown in Figure 48.

Amend 5
Aug 2011

Amend 5
Aug 2011

Amend 5
Aug 2011

Amend 2
Jul 2005

Amend 5
Aug 2011

Amend 5
Aug 2011

COMMENT:

Reduced cover for barge and apron flashings may be applicable for specifically designed roofs in low wind zones.

Amend 2
Jul 2005

Refer to the New Zealand Metal Roof and Wall Cladding Code of Practice for additional guidance on ridge to hip flashings.

Amend 5
Aug 2011

Figure 43: Ridge to hip flashings
Paragraphs 8.4.11 and 8.4.12

NOTE: Flashing cover varies according to wind zone - refer Table 7.
For other ridge to hip flashings refer to New Zealand Metal Roofing and Wall Cladding Code of Practice.

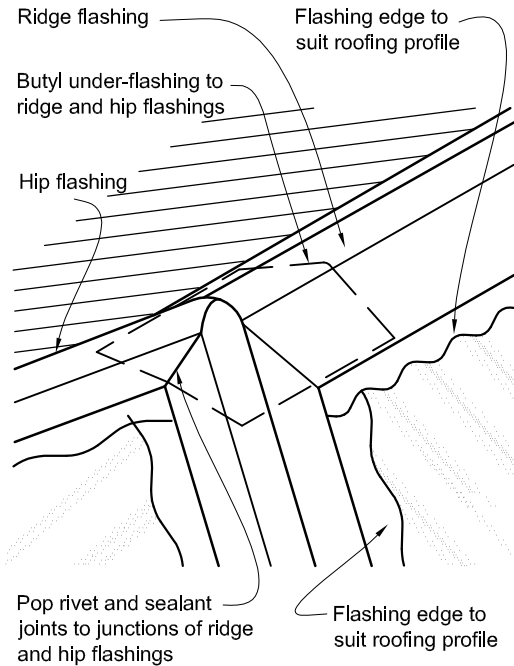

Amend 5
Aug 2011

Amend 2
Jul 2005

Amend 2
Jul 2005

Errata 2
Dec 2011

Errata 2
Dec 2011

Amend 2
Jul 2005

Figure 44: Apron flashing and change in pitch for profiled metal
Paragraphs 4.5, 8.4.11, 8.4.12, Table 7

NOTE: X = variable according to wind zone - refer Table 7.

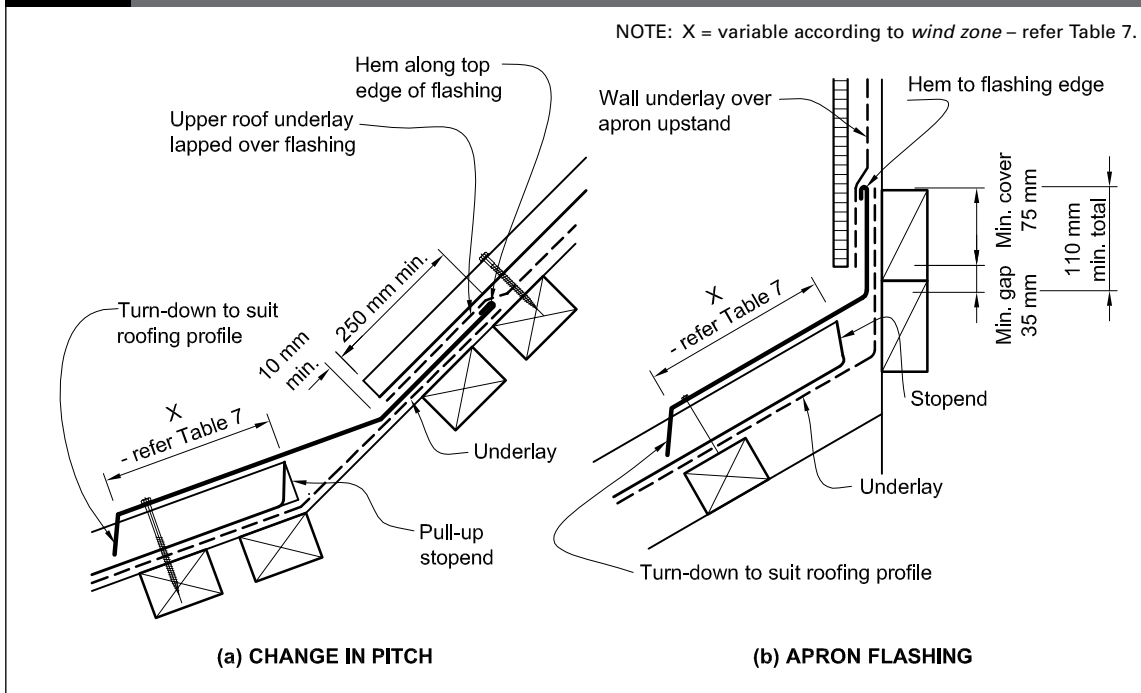

Amend 2
Jul 2005

Amend 5
Aug 2011

Amend 2
Jul 2005

Figure 45: Eaves and roof/wall ridge for profiled metal
Paragraphs 4.5, 8.4.11, 8.4.12, Table 7

Errata 2
Dec 2011

Eave flashing required where all of the following conditions are met:

- Roof slope less than or equal to 10°, and
- soffit width less than or equal to 100 mm, and
- wind zones are Very High or Extra High

Profiled metal roofing

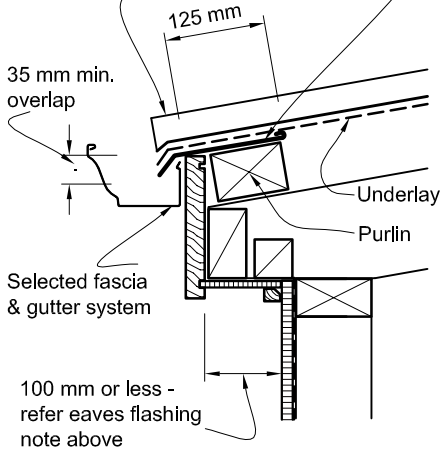

(a) EAVE

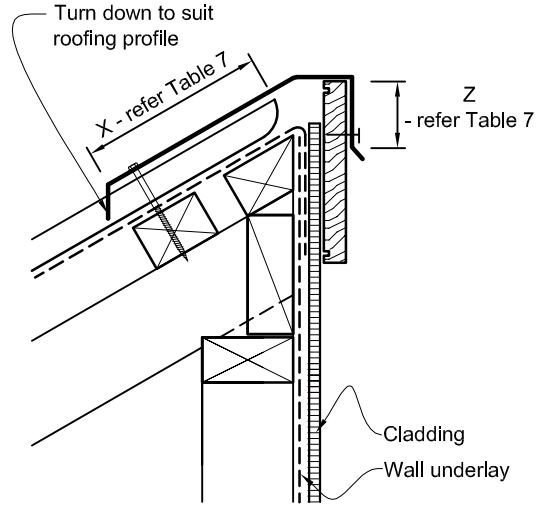

(b) ROOF / WALL RIDGE

Amend 2
Jul 2005

Amend 5
Aug 2011

Amend 2
Jul 2005

Figure 46: Ridge and hip flashings for profiled metal
Paragraphs 4.4, 4.5, 8.4.11, 8.4.12, Table 7

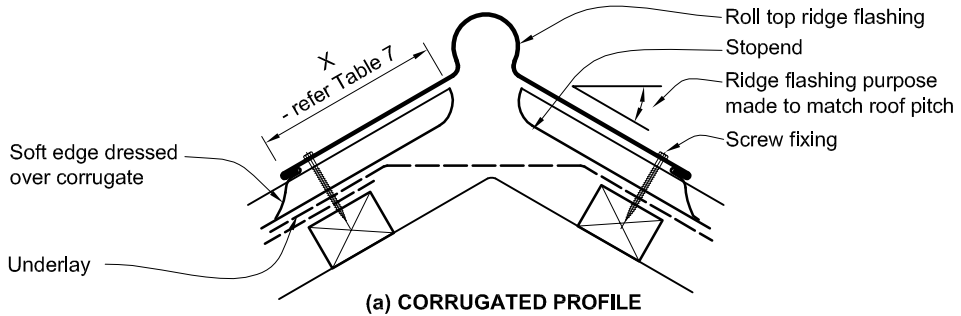

(a) CORRUGATED PROFILE

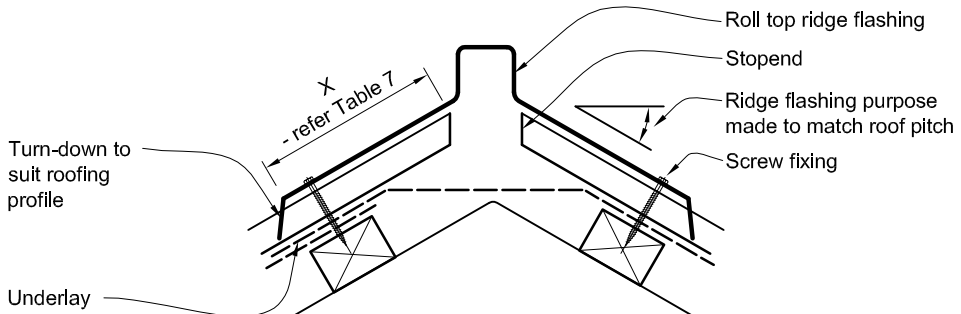

(b) TRAPEZOIDAL PROFILE

Amend 2
Jul 2005

Amend 2
Jul 2005

Amend 5
Aug 2011

Figure 47: Barge flashings for profiled metal
Paragraphs 8.4.11, 8.4.12, Table 7

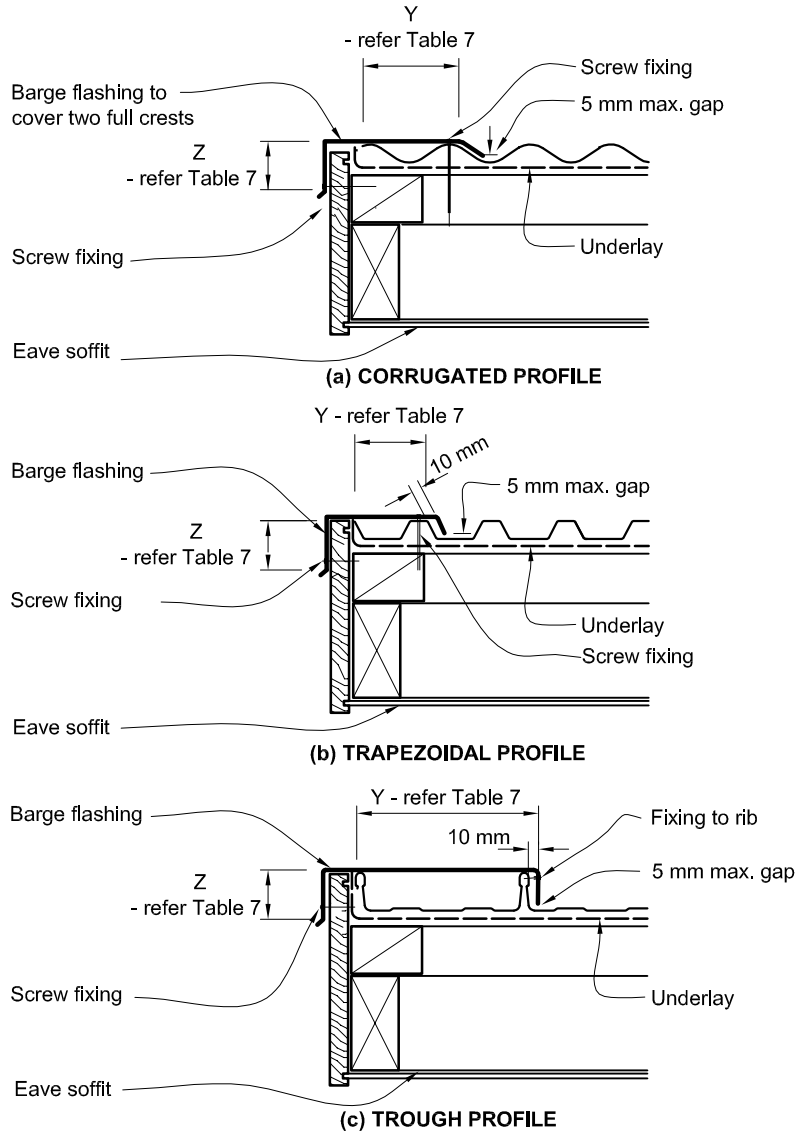

Amend 2
Jul 2005

Amend 2
Jul 2005

Amend 2
Jul 2005

Amend 5
Aug 2011

Figure 48: Parallel apron flashings for profiled metal
Paragraphs 8.4.11, 8.4.12, Table 7

Amend 2
Jul 2005

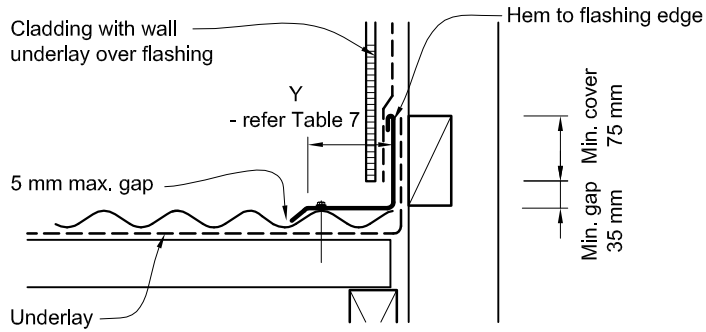

(a) CORrugATED PROFILE

Amend 2
Jul 2005

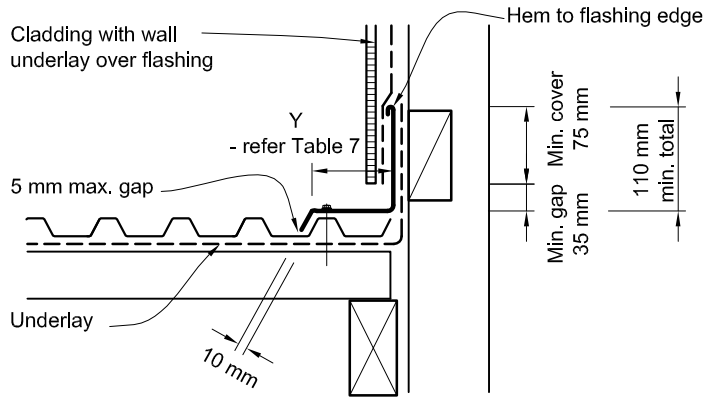

(b) TRAPEZOIDAL PROFILE

Amend 2
Jul 2005

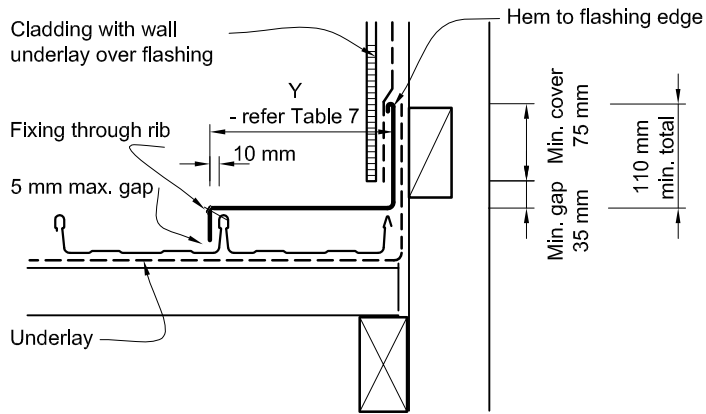

(c) TROUGH PROFILE

Amend 5
Aug 2011

8.4.13 Stopends

The top ends of profiled metal roof *cladding* shall have *stopends* as shown in Figure 49 for *trapezoidal* and *trough profile* metal roof *cladding*, where:

- a) The *roof pitch* is less than 25°, or
- b) The *building* is in a High/Very High/Extra High *wind zone*.

Amend 5
Aug 2011

Amend 5
Aug 2011

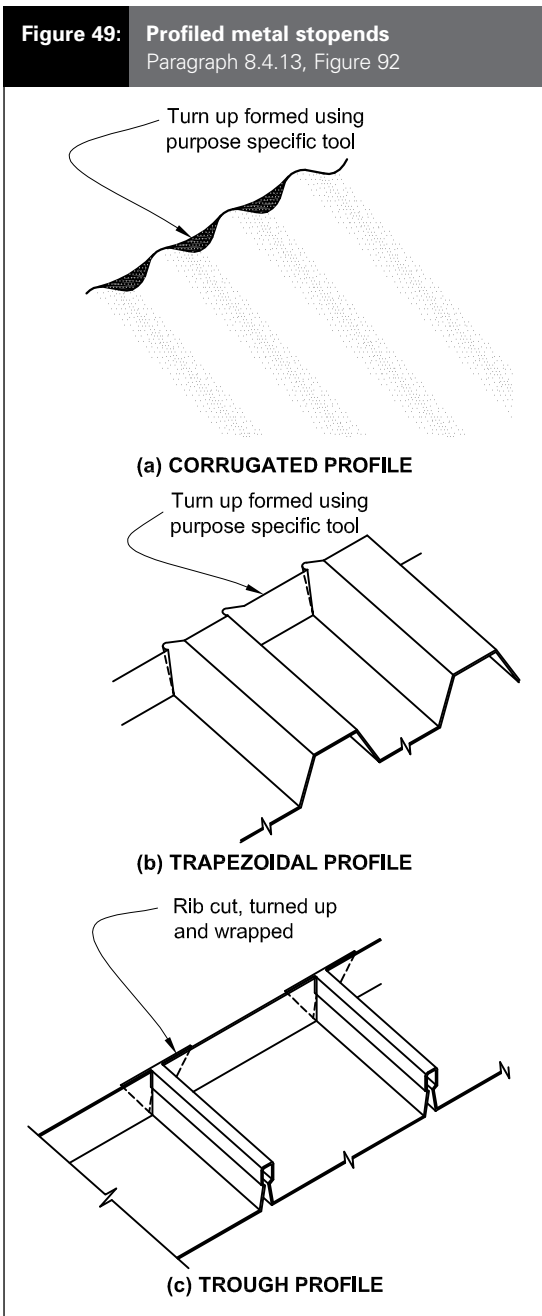

Amend 5
Aug 2011

8.4.14 Turn-downs at gutters

The lower ends of *trapezoidal* and *trough profile* roofing shall be turned down at gutters, where the *roof pitch* is less than 10°.

Amend 5
Aug 2011

The turn-down shall be 30° from the plane of the sheet.

COMMENT:

Specific tools are available and should be used to turn up or turn down ends. Care should be taken to ensure the sheet does not split.

Refer to the New Zealand Metal Roof and Wall Cladding Code of Practice for guidance on methods.

Amend 2
Jul 2005

8.4.15 Profile closure

Preformed compressible seals shall not be used at the *eaves*.

Amend 5
Aug 2011

COMMENT:

Refer to the New Zealand Metal Roof and Wall Cladding Code of Practice for guidance.

8.4.16 Hidden, valley and internal gutters

Hidden, *valley* and internal *gutters* shall be in accordance with Paragraph 8.1.6.

Amend 5
Aug 2011

8.4.16.1 Hidden gutters

Parallel *hidden gutters* shall be as shown in Figure 50 and Paragraph 8.1.6.2.

Amend 2
Jul 2005

8.4.16.2 Valley gutters

Valley gutters shall be in accordance with catchment areas shown in Table 8, and as shown in Figure 51 and Paragraph 8.1.6.2.

Amend 2
Jul 2005
Amend 5
Aug 2011

COMMENT:

Refer to the New Zealand Metal Roof and Wall Cladding Code of Practice for additional guidance on sizing, materials and fixing.

8.4.16.3 Internal gutters

Internal gutters shall be as shown in Figure 52 and Paragraph 8.1.6.1.

Amend 5
Aug 2011

Amend 2
Jul 2005

Figure 50: Parallel hidden gutter for profiled metal
Paragraphs 4.3, 4.5, 8.1.6.2 and 8.4.16

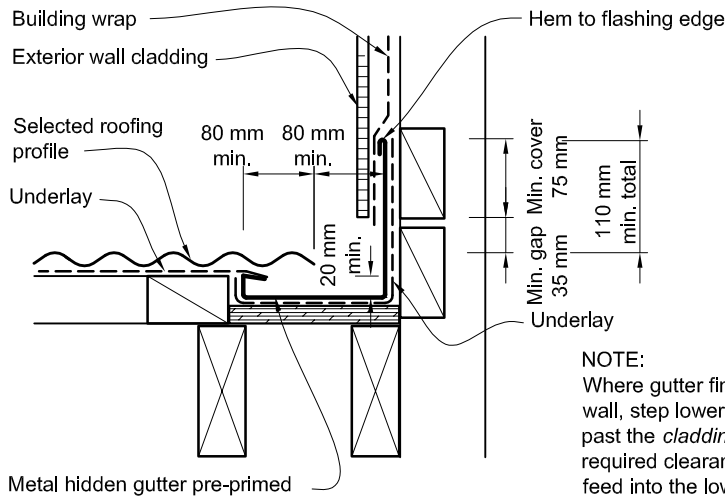

Amend 2
Jul 2005

Amend 5
Aug 2011

Figure 51: Valley gutters for profiled metal
Paragraphs 4.3, 4.5, 8.1.6.2 and 8.4.16

NOTE: (1) Refer to Table 8 for maximum roof catchment areas for *valley gutters*.
(2) Minimum width of *valley gutter* may reduce to 160 mm, providing roof catchment area is in accordance with Table 8. In this case, cover of roof cladding over gutter shall be reduced to 60 mm to provide a clearance gap of 40 mm.

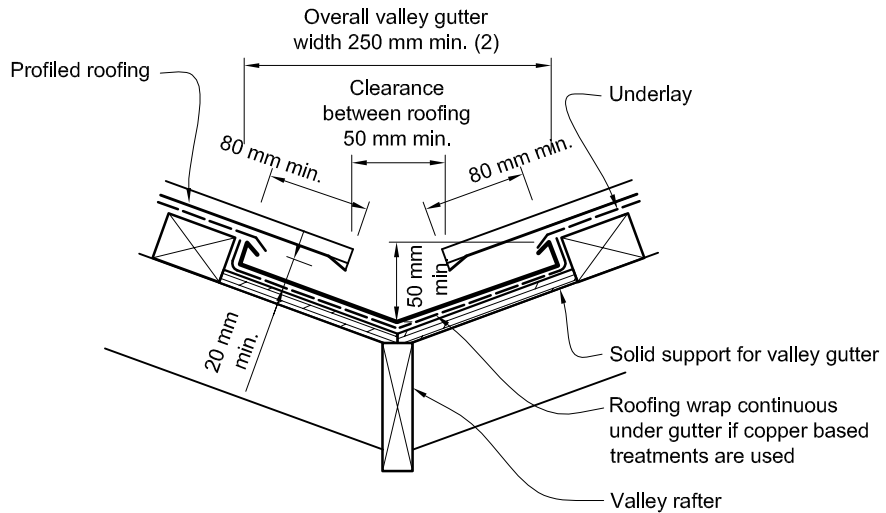

Amend 5
Aug 2011

Amend 2
Jul 2005

Amend 2
Jul 2005

Figure 52: Internal gutter for profiled metal
Paragraphs 4.3, 4.5, 8.1.6.1 and 8.4.16

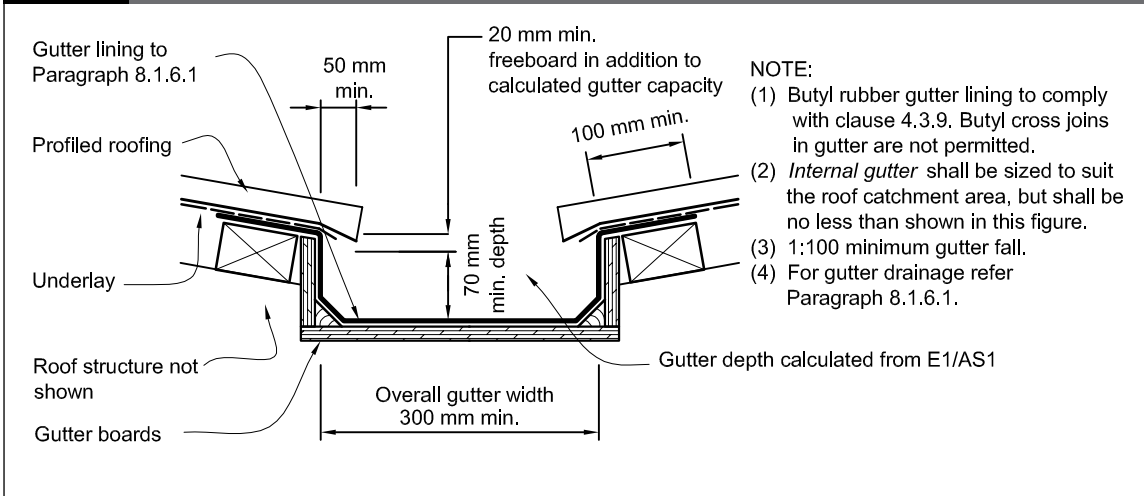

Amend 2
Jul 2005

Amend 5
Aug 2011

8.4.17 Roof penetrations

The maximum length of profiled *roof cladding* above penetrations shall be as shown in Table 17.

The edge of roofing penetrations over 200 mm wide shall be supported in either direction with additional *framing* as shown in Figure 21.

Roof penetrations shall be flashed as follows:

- a) Pipe penetrations up to 85 mm shall be flashed using an *EPDM boot flashing* as shown in Figure 53,
- b) Pipe penetrations up to 500 mm shall be flashed using a *soaker flashing* and *EPDM boot flashing* as shown in Figure 54,

- c) Rectangular penetrations up to 1200 mm wide shall be flashed using a *soaker type flashing* as shown in Figure 55.

COMMENT:

Penetrations on lower pitched *roofs*, larger penetrations, or needing specialised complex *flashings* will require *specific design* to suit the particular circumstances.

The New Zealand Metal Roof and Wall Cladding Code of Practice should be consulted for guidance.

Amend 2
Jul 2005

Amend 5
Aug 2011

Amend 2
Jul 2005

Table 17: Catchment areas for profiled metal
Paragraphs 8.1.7, 8.4.17, Table 9, Figure 22

| Penetration width | Maximum roof length above penetration in metres | | |
|-------------------|---|-------------------|-------------------|
| | Corrugated | Trapezoidal | Trough profile |
| 800 to 1200 mm | 4 m | 8 m | 16 m |
| 600 to 800 mm | 6 m | 12 m | 18 m (refer Note) |
| 400 to 600 mm | 8 m | 16 m | 18 m (refer Note) |
| 0 to 400 mm | 12 m | 18 m (refer Note) | 18 m (refer Note) |

NOTE: Limited to 18 m as per the limitations of this Acceptable Solution.

Amend 5
Aug 2011

Figure 53: Flashing for small pipes
Paragraphs 8.3.10, 8.4.17, 9.6.8.5 and 9.6.9.6

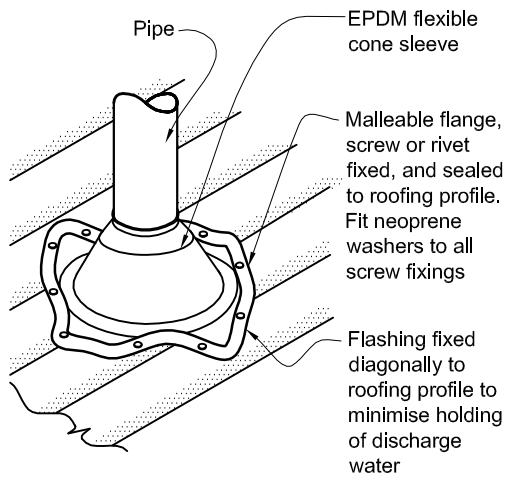

NOTE:
(1) Max. roof pitch for this flashing 45°, minimum pitch 10° if base of flange covers one or more complete troughs.
(2) For pipes up to 85 mm diameter.

Amend 5
Aug 2011

Figure 54: Soaker flashing for pipe penetrations
Paragraph 8.4.17

NOTE: (1) Suitable for pipes from 86 mm to 500 mm diameter.
(2) Suitable only for roof pitches of 10° or more.

Soaker flashing to be fully supported by roofing under - refer Figure 21

Lines of roof penetration

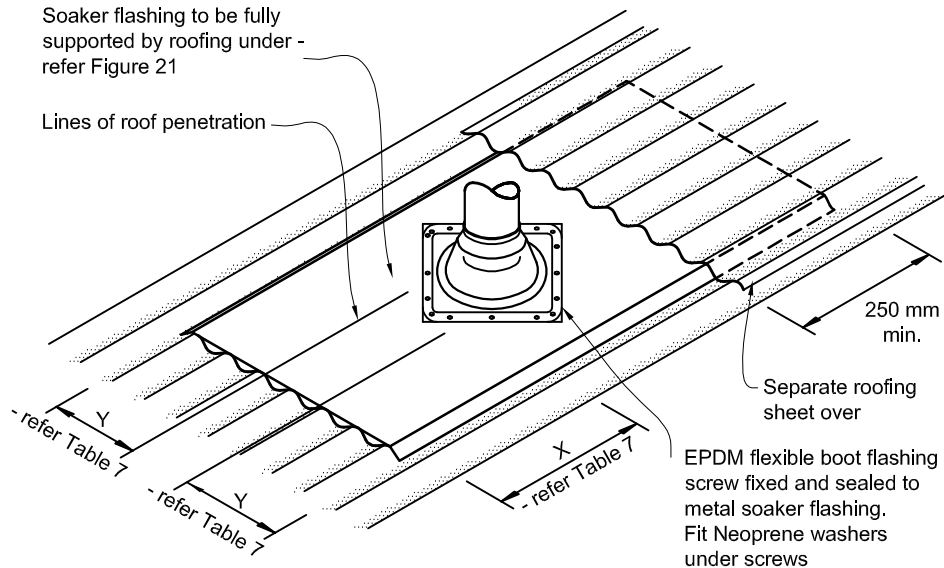

Errata 2
Dec 2011

Amend 2
Jul 2005

Amend 2
Jul 2005

Amend 5
Aug 2011

Figure 55: Soaker flashing for other penetrations
Paragraph 8.4.17, Table 17

NOTE: (1) Suitable for penetrations up to 1200 mm wide.
(2) Suitable only for roof pitches of 10° or higher.

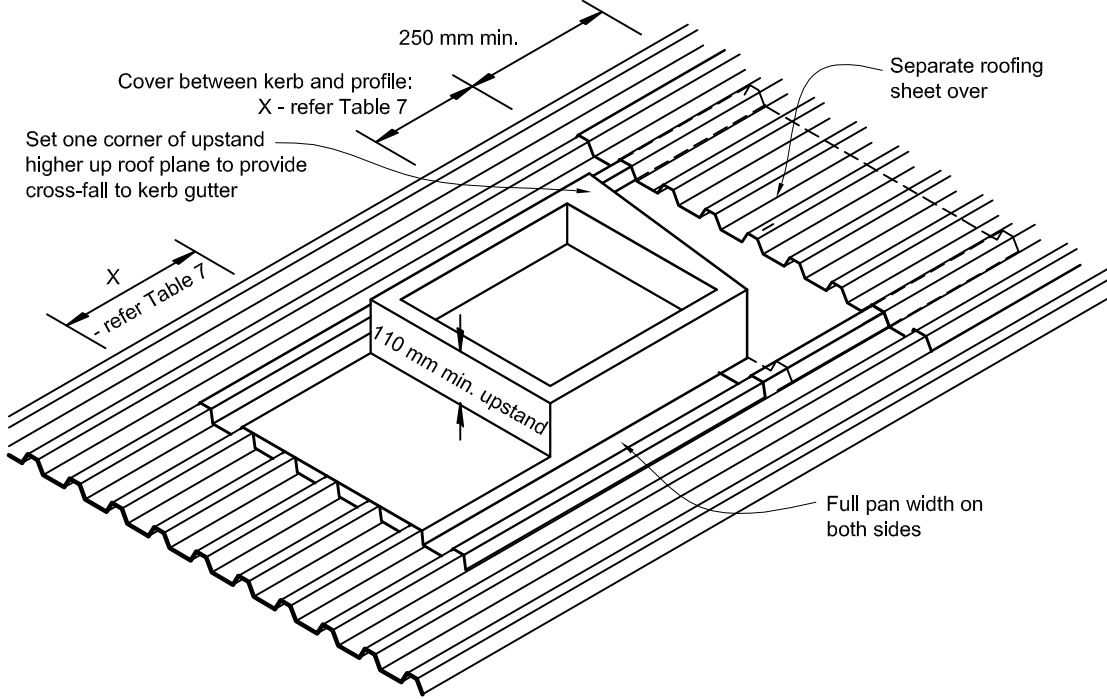

Amend 5
Aug 2011

Amend 2
Jul 2005

8.5 Membrane Roofs and Decks**8.5.1 Limitations**

This Acceptable Solution is limited to *membranes* composed of butyl or *EPDM* installed over plywood substrates for:

- Amend 5
Aug 2011
- Amend 5
Aug 2011
- Amend 2
Jul 2005
- Amend 5
Aug 2011
- Amend 5
Aug 2011
- a) *Roofs* with a minimum fall of 2° (1:30),
 - b) *Decks* with:
 - i) a minimum fall of 1.5° (1:40),
 - ii) a maximum area of 40 m²,
 - iii) no steps in level within *deck* area except into gutters,
 - iv) no integral roof gardens, and
 - v) no downpipe direct discharge to *deck*,
 - c) Internal gutters with a minimum fall of 1 in 100, with no cross seams in the gutters, and
 - d) *Decks* with removable raised surfaces to give level access as shown in Figure 17A.

The application of directly applied wearing or decorative surfaces to *membranes* is not covered in this Acceptable Solution.

COMMENT:

EPDM and butyl rubber *membranes* are subject to damage when on trafficable roof-*decks*. A suitable wearing surface will help reduce such damage.

Increases in slopes from the previous version recognise deflection tolerances in NZS 3604 and in-service loadings by *building* owners.

8.5.2 General

Closed-in *construction* spaces under *membrane roofs* and *decks* require adequate ventilation to prevent the accumulation of moisture under the *membrane*. Maintain a minimum gap of 20 mm between the underside of the substrate and any insulation, and for *membrane roofs* greater than 40 m², refer to manufacturer's details for *roof* cavity vents and/or substrate vent requirements.

COMMENT:

Refer to Paragraph 1.5 for qualification of installers.

Amends
2 and 5

8.5.3 Plywood substrates

Plywood shall be:

- a) A minimum of 17 mm complying with AS/NZS 2269,
- b) At least CD Grade Structural plywood with the sanded C face upwards, and
- c) H3 with treatment type compatible with *membrane* and adhesives used, and kiln dried after treatment.

Amend 2
Jul 2005

COMMENT:

The compatibility of LOSP-treated timber must be checked with *membrane* suppliers.

If using plywood containing copper-based preservatives, check the compatibility of adhesives and *membranes* with copper with the product manufacturers.

Amend 5
Aug 2011

8.5.4 Butyl and EPDM

Butyl rubber and *EPDM* rubber sheet and system components used for *membrane* roofing or *decks* shall:

- a) Be a minimum thickness of:
 - i) 1 mm for roofing, or
 - ii) 1.5 mm for *decks*, and

Amend 5
Aug 2011

Amend 2
Jul 2005

Refer to Paragraph 8.1.6.1 for *membranes* to gutters

Amend 5
Aug 2011

- b) Comply with the following parts of Table 1 in ASTM D6134:
 - i) tensile strength,
 - ii) elongation,
 - iii) water absorption,
 - iv) water vapour permeance, and
 - v) heat aging followed by:
 - a. tensile strength
 - b. elongation, and
- c) Have adhesives, primers, seam tapes and pre-formed components where supplied by the manufacturer that:
 - i) comply with BRANZ EM 5, and
 - ii) are part of a complete system approved by the manufacturer or supplier of the *membrane*.

Amend 5
Aug 2011

8.5.5 Installation

8.5.5.1 Plywood

Substrates must be dry when *membranes* are applied. The plywood and timber substructure must be a maximum moisture content of 20% when a *membrane* is adhered.

Amend 5
Aug 2011

COMMENT:

This will generally require substrates to be covered to prevent rain wetting, or to be pre-primed to avoid moisture uptake.

Manufacturers' recommendations should be consulted, as some require a lower moisture content in order to validate guarantees.

Plywood substrates shall be fixed according to the following requirements:

- a) Panels shall be laid with staggered joints (brick bond),
- b) Panels shall be laid with the face grain at right angles to the main supports,
- c) Supports in b) shall be at 400 mm maximum centres,
- d) The edge of sheets shall be supported with *dwangs* or *framing*,
- e) External edges shall be chamfered with a minimum radius of 5 mm,
- f) A 20 mm H3.2 triangular fillet shall be used at the base of any 90° upstand, and
- g) Shall be fixed:
 - i) with 3 mm gaps between all sheets,
 - ii) using 10 g x 50 mm stainless steel countersunk head screws,
 - iii) at 150 mm centres on edges, and
 - iv) at 200 mm centres in the body of the sheets.

Amend 2
Jul 2005

Amend 5
Aug 2011

8.5.5.2 Butyl and EPDM

Seam tapes shall be used on all joints of:

- a) *Roofs* or *decks* with falls less than 5° (1:12),
- c) Penetrations through the *membrane* where butyl or *EPDM flashing* is required,
- d) *EPDM membrane*, and
- e) Butyl *membranes* that contain *EPDM*.

Amend 5
Aug 2011

COMMENT:

Coloured butyl *membranes* contain *EPDM*, which makes them more difficult to adhere properly.

Seams should be aligned parallel to the fall of the *deck* to minimise ponding.

Where a penetration is made through the *membrane* subsequent to laying, the *flashing* should be installed by the applicator of the *membrane* system.

Amend 5
Aug 2011

All joints in the plywood and junctions of plywood with other materials shall have 25 mm polyethylene release tape applied before application of the *membrane*.

8.5.6 Roof and deck drainage

Membrane roofs and *decks* shall be constructed to provide:

- a) Falls as shown in Figure 56 and details in Figures 57–64
- b) A minimum of 100 mm below an adjoining threshold as shown in Figure 62
- c) *Membrane upstands* against all *walls*, *parapets*, or *enclosed balustrades* extending to a minimum level of 150 mm above *deck* level as shown in Figure 62.

Amend 2
Jul 2005

COMMENT:

If the clearance of the *cladding* from the *deck* or *roof* surface is at the minimum of 35 mm, give an overlap of 115 mm to the *cladding*.

- d) Water discharging either:
 - i) into a *roof* or gutter outlet with a minimum diameter of 75 mm as shown in Figure 64 with either:
 - an overflow as shown in Figure 63 (c) or
 - an extra outlet, with both outlets sized to take the full required capacity.
 - or,

Amend 5
Aug 2011

Errata 2
Dec 2011

- ii) via a *scupper*, into a gutter, or rainwater head, as shown in Figure 63 (a), (b) and (d).
- e) Gutters formed with continuous butyl or EPDM strip complying with Paragraph 4.3.9, with no cross-joints.

COMMENT:

Refer to E1/AS1 for specific drainage requirements outside the scope of this Acceptable Solution.

Seams in gutters are particularly difficult to form at outlets through *enclosed balustrade walls*, and the risk of failure is high. Failure of a seam can result in damage to underlying *walls*.

Amend 5
Aug 2011

Amend 5
Aug 2011

8.5.7 Control joints

All *control joints* in the substrate shall be accommodated in the *membrane roof* design.

The design of *control joints* for *membrane roofing* is subject to *specific design* and is outside the scope of this Acceptable Solution.

Amend 2
Jul 2005

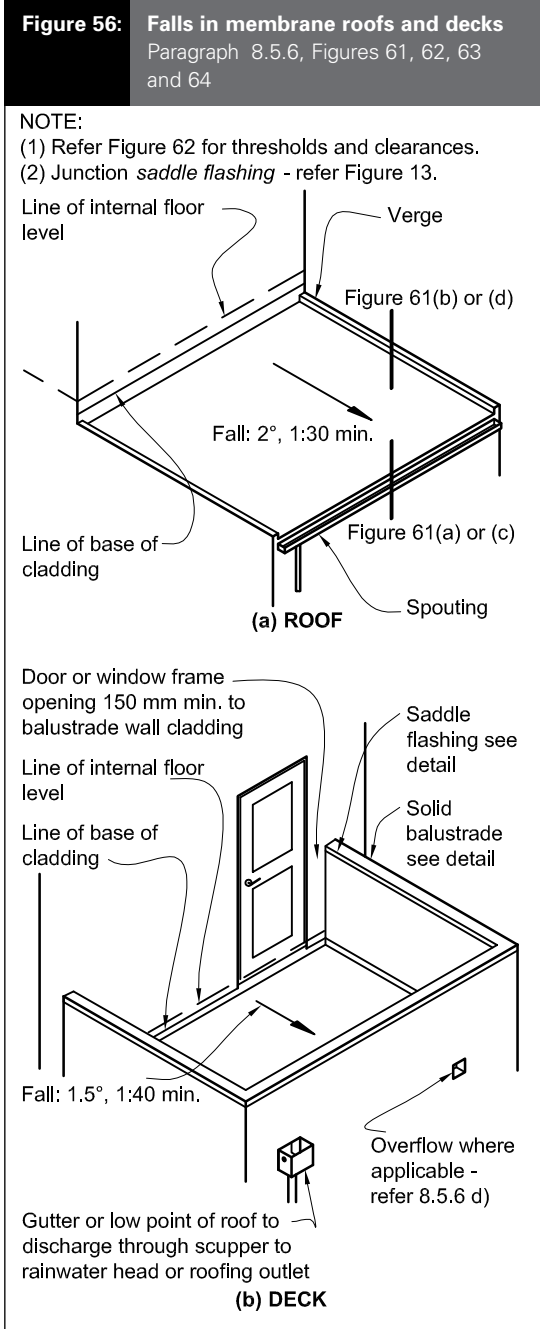

Amend 2
Jul 2005

Errata 2
Dec 2011

Amend 5
Aug 2011

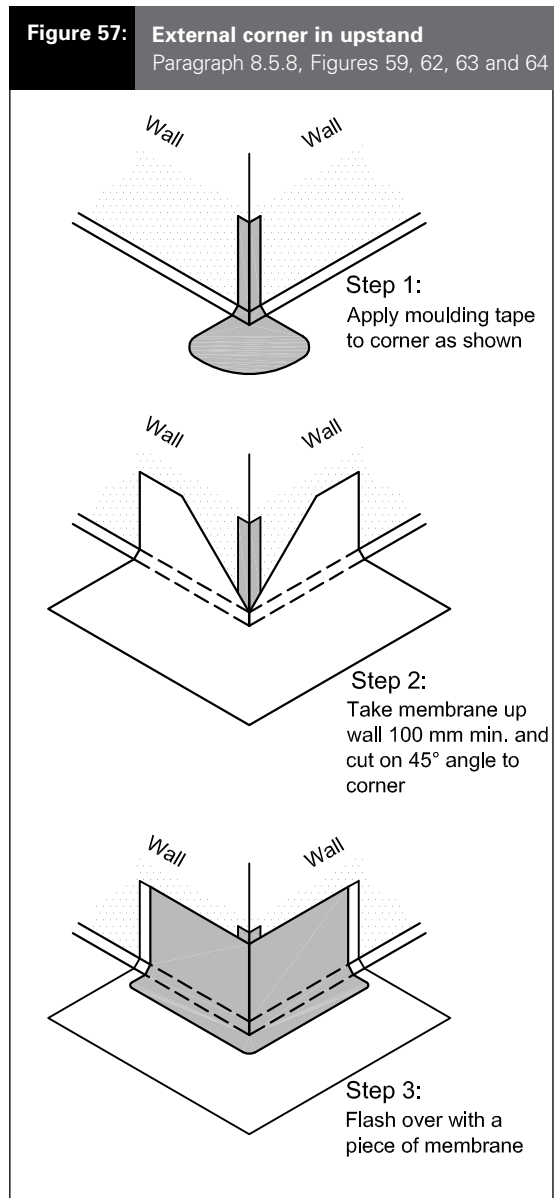

Amend 5
Aug 2011

Figure 58: Internal corner in upstand
Paragraph 8.5.8, Figures 62 and 64

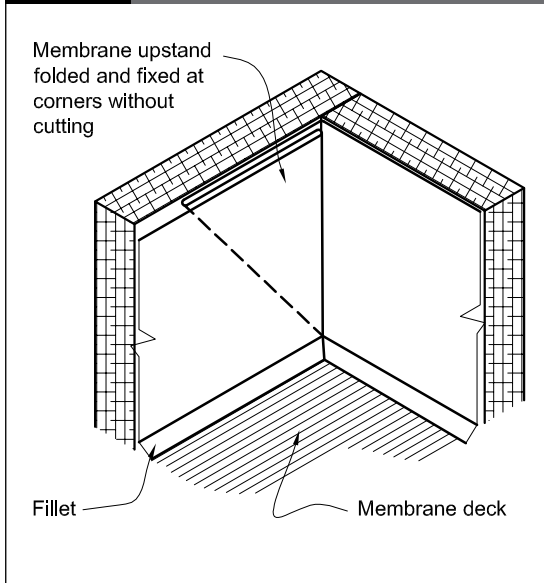

Amend 2
Jul 2005

Amend 5
Aug 2011

8.5.8 Junctions

All junctions of *roof* or *deck* to *walls*, *parapets* and *enclosed balustrades* shall be made *weathertight* using the following appropriate details:

- a) Figure 57: External corner in upstands,
- b) Figure 58: Internal corner in upstands,
- c) Figure 61: Verges and *eaves*,
- d) Figure 62: Junctions of *decks* and *walls*, and
- e) Drainage details to Paragraph 8.5.6.

8.5.8.1 Junctions with walls

Junctions of *membrane decks* or *walls* shall be formed as shown in Figure 62.

Amend 5
Aug 2011

The bottom of the wall *cladding* above the *deck* or *roof* surface shall be sealed prior to fixing.

Amend 5
Aug 2011

Figure 59: Roofing penetration in membrane
Paragraphs 8.5.8 and 8.5.9

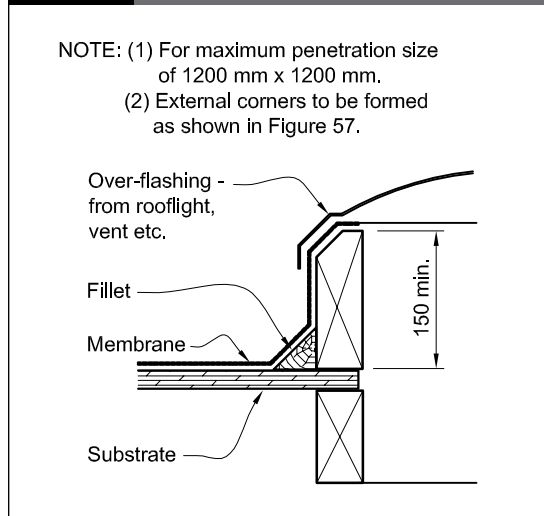

Amend 5
Aug 2011

Figure 60: Pipe penetration in membrane
Paragraph 8.5.9

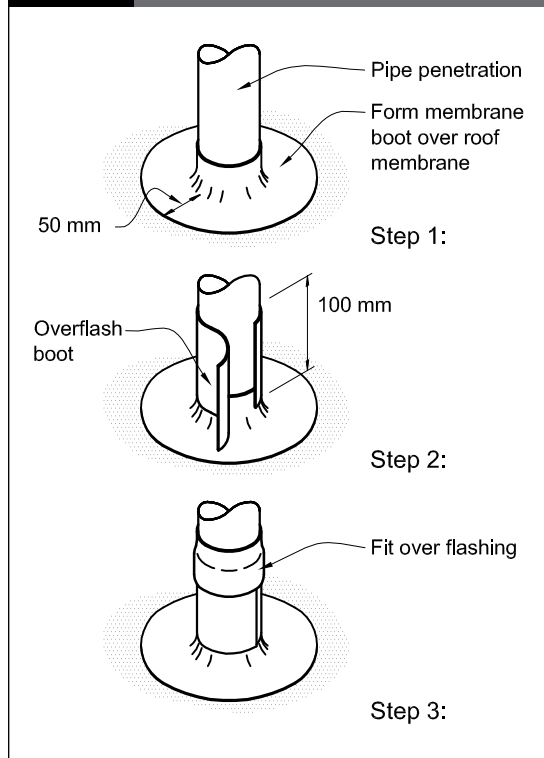

Amend 5
Aug 2011

8.5.9 Penetrations

Penetrations through *membrane roofs* and *decks* shall be as shown in Figure 59 and Figure 60.

Figure 61: Verges in membrane
Paragraph 8.5.8, Figure 56

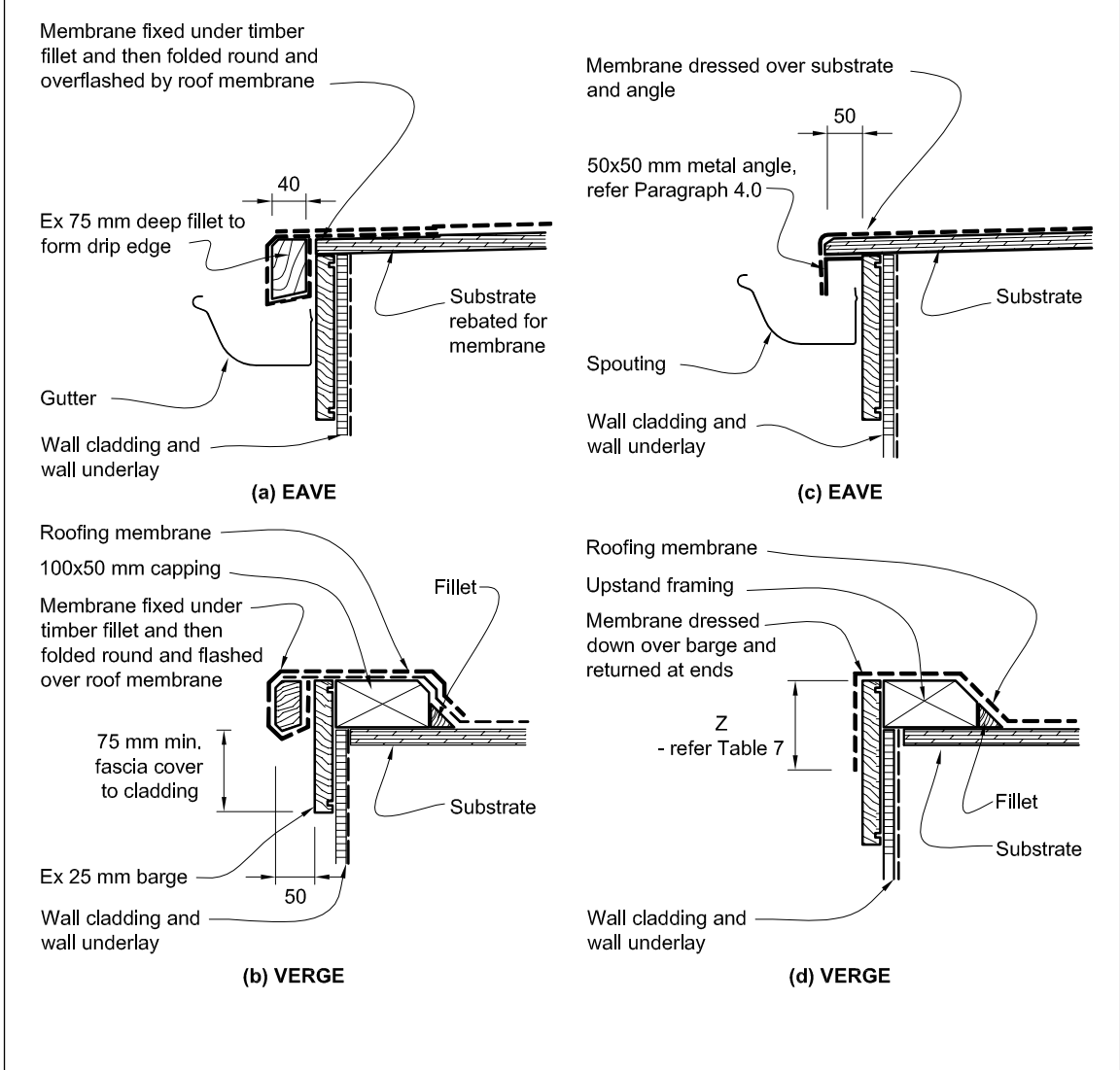

Errata 2
Dec 2011

Errata 2
Dec 2011

Amend 2
Jul 2005

Errata 2
Dec 2011

Amend 2
Jul 2005

Amend 5
Aug 2011

8.5.9.1 Handrails

Fixing of posts for *handrails* into *membrane roofs* or *decks* is not covered by this Acceptable Solution.

COMMENT:

Any fixing of posts into *membrane roofs* or *decks* will require *specific design*.

The fixing of posts into tiles over a *membrane* is particularly risky, and should be avoided.

COMMENT:

Internal outlets should have a dome-type cover to reduce risk of blockage, except where this could constitute a pedestrian hazard.

8.5.10 Gutters

Deck gutters and internal outlets shall be *constructed* as shown in Figure 64.

Amend 5
Aug 2011

Figure 62: Junctions with walls for membrane
Paragraph 7.4.3, Figure 56

NOTE: (1) Internal corners to be formed as shown in Figure 58.
(2) Dimensions are shown to *membrane*. However, where there is an additional material applied over the *membrane*, all dimensions shall apply to the highest level of the wearing surface.

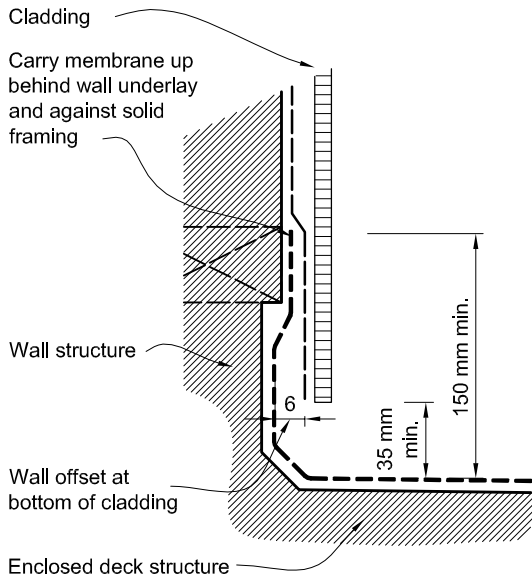

(a) DIRECT FIX CLADDING

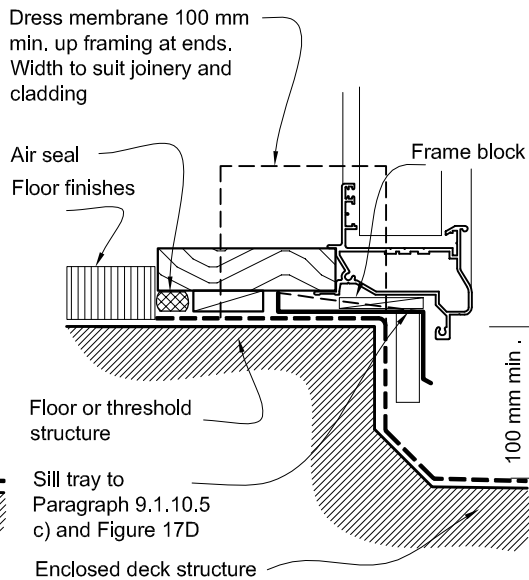

(b) DIRECT FIX THRESHOLD AT OPENING

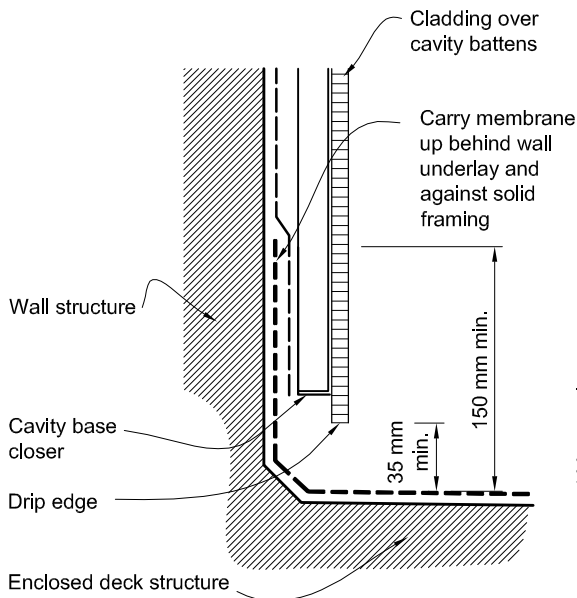

(c) CAVITY FIXED CLADDING

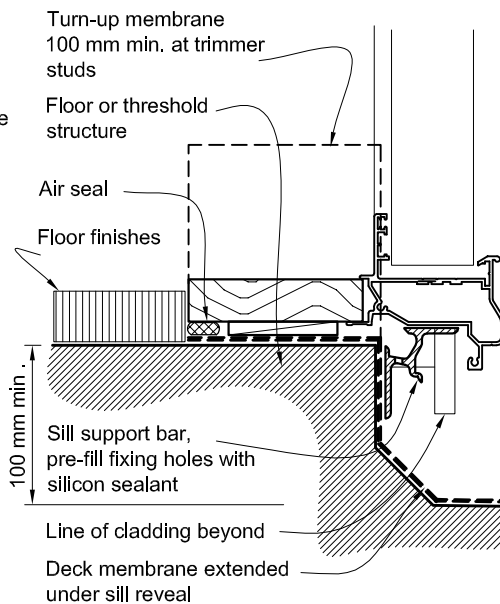

(d) CAVITY THRESHOLD AT OPENING

Amend 2
Jul 2005

Amend 2
Jul 2005

Errata 2
Dec 2011

Amend 5
Aug 2011

Figure 63: Rainwater head and scupper opening in membrane
Paragraph 8.5.6, Figure 56

NOTE: (1) Use preformed *scuppers* where provided by the membrane supplier .
(2) External corners of *scupper* opening to be formed as shown in Figure 57.

Continuous membrane dressed through opening with upper edges sealed against cladding. Return over rainwater head at sides

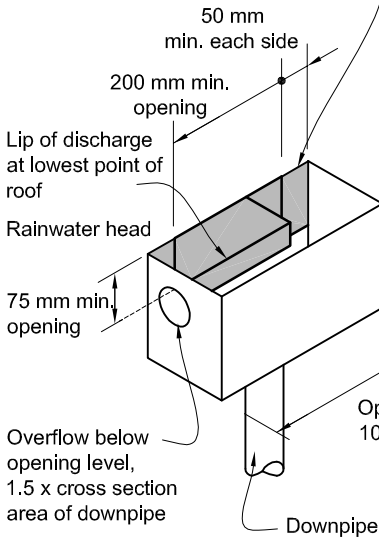

(a) DECK OUTLET

Cavity battens with base closure and drip edge to cladding at opening

Continuous membrane dressed through base and up sides of opening with upper edges sealed against cladding. Return along back of rainwater head

Return membrane into rainwater head

Membrane dressed over 50x50 mm aluminium angle rebated into substrate

Return membrane at end of lip
Rainwater head and downpipe

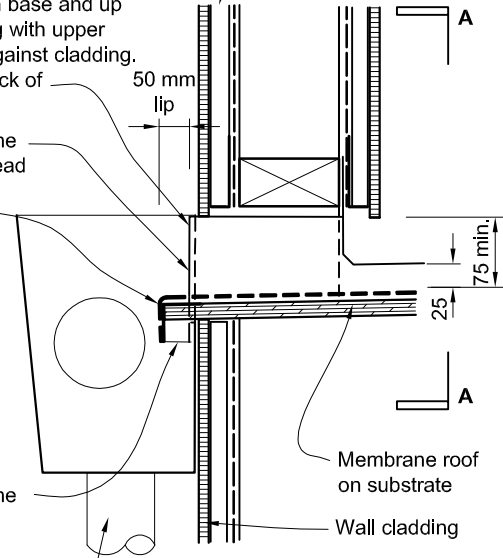

(b) OUTLET THROUGH WALL

Refer to cladding for cavity finish

Continuous membrane dressed through base and up sides of opening

Membrane turned over lip

50x50 mm aluminium angle drip edge rebated into substrate

50 mm lip

(c) OVERFLOW

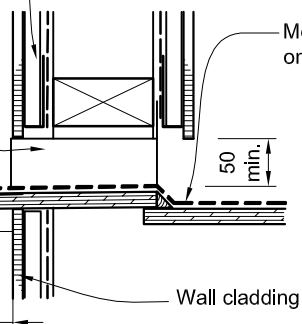

Line of membrane lapped 50 mm min. behind wrap under cladding

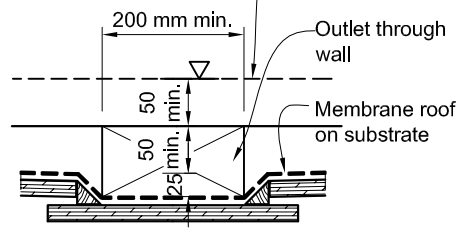

(d) SECTION A - A

Amend 2
Jul 2005

Amend 5
Aug 2011

Figure 64: Gutters and outlets in membrane
 Paragraphs 8.5.6 and 8.5.10

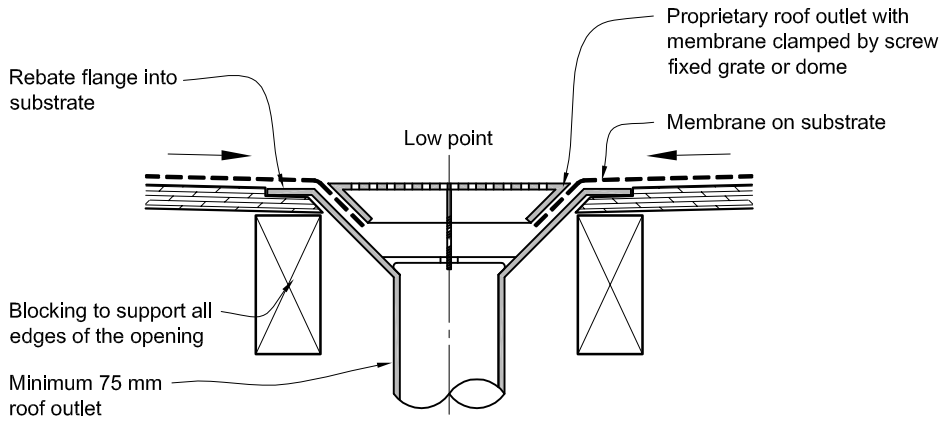

(a) TYPICAL ROOF OUTLET

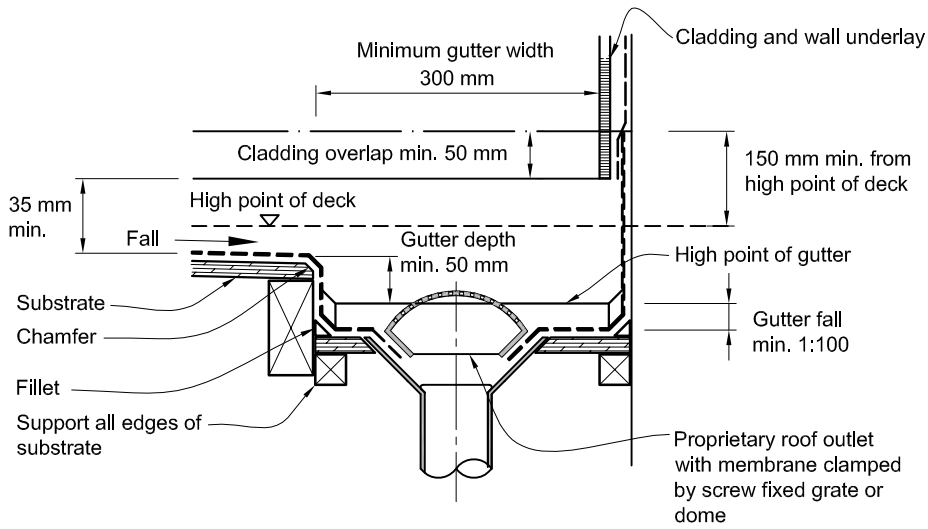

(b) EDGE GUTTER

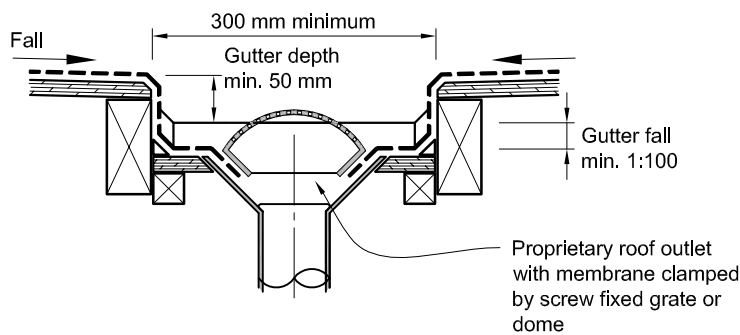

(c) CENTRAL GUTTER

Amend 5
 Aug 2011

9.0 Wall Claddings

9.1 General

Wall claddings shall meet the requirements of NZBC E2.3.2 to E2.3.7, and comply with the provisions of Paragraph 9.1.1 to Paragraph 9.9.

Claddings in Extra High wind zones require:

- a) Rigid underlays to Paragraph 9.1.7.2
- b) Drained cavities to Paragraph 9.1.8
- c) Hooks and hems on flashing upstands, and additional 25 mm height to Paragraph 4.6.

Amend 5
Aug 2011

9.1.1 Limitations

This Acceptable Solution is limited to the wall cladding systems listed in Paragraph 3.3. Table 3 lists wall cladding systems that shall be used for buildings with varying risk scores.

The method of establishing the level of risk associated with the use of a specific wall cladding is given in Paragraph 3.1. Based on this risk score, a wall cladding may require the inclusion of a drained cavity as described in Paragraph 9.1.8.

Amend 5
Aug 2011

Claddings in Extra High wind zones require rigid underlays and drained cavities – refer to Table 3.

9.1.2 Maintenance

Amend 5
Aug 2011

Maintenance of wall claddings shall be carried out as necessary to achieve the expected durability of the material – refer to Paragraph 2.5.

9.1.3 Bottom of cladding

Separations, clearances to ground level, and overlaps shall be as shown in Figure 65 and Table 18.

Clearances to roof claddings and decks shall be minimum 35 mm – refer to Table 7 and Figure 18.

Clearances shall be measured to:

- a) The finished plane of any adjacent horizontal surface, or
- b) The top surface of any adjacent sloped or horizontal apron flashing.

Amend 5
Aug 2011

COMMENT:

This keeps the bottom edge of the cladding dry, and allows cleaning and painting of the bottom surfaces.

Figure 65: Levels and garage openings
Paragraphs 9.1.3, 9.1.3.4, 9.2.5, Table 18

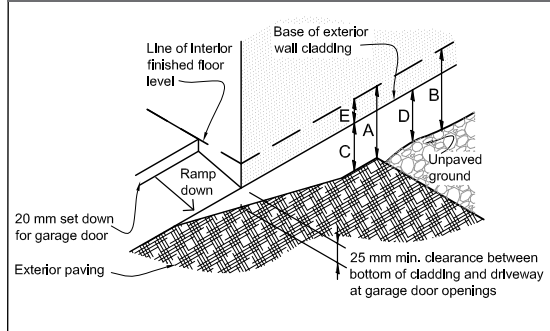

Amend 5
Aug 2011

Table 18: Minimum clearances
Paragraphs 9.1.3, 9.1.3.1, 9.1.3.2, 9.1.3.3, 9.1.3.4, 9.1.3.5 and 9.2.7

| Minimum clearances (mm) | Masonry veneer | | Other claddings | | | | |
|-------------------------|----------------|-----|-----------------|-----|-----|-----|----|
| | A | B | A | B | C | D | E |
| Concrete slab | 100 | 150 | 150 | 225 | 100 | 175 | 50 |
| Timber floor | Refer Note 1) | | 100 | 175 | 50 | 2) | |

NOTE: 1) Refer to NZS 3604 for requirements.
2) Cladding to extend minimum 50 mm below bearer or lowest part of timber floor framing.

Amend 5
Aug 2011

Amend 5
Aug 2011

9.1.3.1 Concrete slabs

Slab levels shall be set to allow reinstatement of final landscaped ground levels as outlined in Figure 65 and Table 18.

COMMENT:

NZS 3604 may require greater ground clearances depending on floor type and materials.

The likely final landscaped ground levels are to be taken into account when planning foundations and earthworks to avoid reductions to the minimum ground clearances in the finished building.

Amend 5
Aug 2011

9.1.3.2 Masonry veneer clearances

The height of the floor slab above finished ground level shall be in accordance with Figure 73D and as shown in Table 18.

Amend 5
Aug 2011

9.1.3.3 Bottom of wall claddings for concrete ground slabs (except masonry veneer)Amend 5
Aug 2011

At concrete slab level, the base of the *cladding system* shall be as shown in Table 18, and:

- a) Finish a minimum of:
 - i) 100 mm above a paved surface, or
 - ii) 175 mm above finished unpaved surface,
- b) Overlap the concrete slab by 50 mm, and
- c) Be offset horizontally by a minimum of 6 mm for *direct fixed claddings* to prevent capillary action.

Amend 5
Aug 2011Amend 5
Aug 2011**9.1.3.4 Garages and openings to garages**Amend 5
Aug 2011

Refer to Figure 65 and Table 18 for overall level change requirements.

COMMENT:

This paragraph does not apply to garages that are detached outbuildings.

Garage spaces within, or attached to, the *building envelope* shall have:

- a) Openings provided with a 50 mm minimum total level change between the interior and the exterior paving,

COMMENT:

Methods for achieving the required step may include:

- A 50 mm difference in *finished ground level* adjacent to the opening, or
- A raised threshold at the opening, or
- Concrete nibs at the opening.

- b) Provision to drain water away from the threshold of the opening
- c) Rigid *wall underlays*, to Table 23, where external garage *walls* are unlined
- d) linings to garage *walls* adjoining habitable spaces
- e) weather resisting garage doors
- f) window and door details (where included) to Paragraphs 9.2 to 9.9.

Amend 5
Aug 2011**9.1.3.5 Bottom of wall claddings for timber floor framing**Amend 5
Aug 2011

Suspended timber floors shall meet the requirements of NZS 3604. Clearances from paved and unpaved surfaces to the wall *framing* shall be in accordance with NZS 3604, and Table 18.

Amend 5
Aug 2011

At ground floor level, the base of the *cladding system* shall:

- a) Overlap the timber floor structure by 50 mm minimum, and
- b) For walls with *direct fixed claddings*, be offset horizontally from a concrete foundation *wall* by a minimum of 6 mm
- c) Have no direct connection between sub-floor spaces and *drained cavities*.

Amend 5
Aug 2011**COMMENT:**

Where *claddings* require *drained cavities*, care must be taken to ensure air from the subfloor space cannot enter the cavity. This is important, as moisture levels in subfloor air can be high.

9.1.4 Barriers to airflow

This Acceptable Solution requires *external walls* to have barriers to airflow, in the form of:

- a) Interior *linings* with all joints stopped for *wind zones* up to Very High, or
- b) Rigid *underlays* (and *drained cavities*) for *buildings* in Extra High *wind zones* – refer to Paragraph 9.1.7.2
- c) Where walls are not lined, such as attic spaces at gable ends, an air barrier complying with Table 23, fixed to *framing* prior to fixing *cladding* or *cavity battens*
- d) For attached garages, *underlays* to Paragraph 9.1.3.4.

Amend 5
Aug 2011

COMMENT:

The primary function of air barriers and *air seals* is to moderate airflows at junctions and inside the *wall* cavity.

Airflows in certain weather conditions encourage significant amounts of water to move along their path, and it is therefore important to manage airflow in *cavity walls* with barriers and *air seals*.

In the absence of internal *linings*, an air barrier is required to support wind pressures at locations such as gable ends and unlined garage spaces. Air pressure drop is not always across the internal *lining*, indicating the *wall underlay* acts as an air barrier as well.

9.1.5 Wall underlays to wall openings

Prior to window or door installation:

- a) Flexible *wall underlay* shall be cut and dressed into all sides of openings as per Figure 72A and B,
- b) *Flexible flashing tape* shall be applied to head and sill *framing* as shown in Figures 72A and 72B. *Flexible flashing tape* shall:
 - i) comply with Parts 3.2 and 4 of ICBO Acceptance Criteria AC148, and
 - ii) be compatible with the *wall underlay*.

COMMENT:

Dressing the *wall underlay* around the *framing* timber and providing a flexible *air seal* limits airflows around the window reveal.

The *flexible flashing tape* keeps any water that does get past the *cladding*, or through the joinery, from direct contact with the timber.

9.1.6 Air seals

Window, door and other penetration openings shall be provided with flexible *air seals* to minimise the risk of airflows carrying water into the *building wall*. The *air seal* shall be:

- a) Provided between the reveal or frame and the wrapped opening (for example of use, refer to Figure 81),
- b) Installed over a closed cell polyethylene foam (PEF) backing rod, or similar
- c) Made of:
 - i) self-expanding polyurethane foam, or
 - ii) sealant complying with:
 - a. Type F, Class 20LM or 25LM of ISO 11600, or
 - b. low modulus Type II Class A of Federal Specification TT-S-00230C.

COMMENT:

Some sealants can react with bitumen based *flashing* tape, preventing full curing of the sealant. Where necessary, consult sealant manufacturers for application requirements.

Backing rods are used for sealant and for self-expanding polyurethane foam as there is a danger foam will expand to the outside of the *wall* and form a moisture bridge to the interior.

For further information refer to ASTM C1330 for backing rod material performance.

9.1.7 Wall underlay

9.1.7.1 Flexible *wall underlays* shall be in accordance with Table 23, and shall:

- a) Be run horizontally,
- b) Have upper sheets lapped over lower sheets to ensure that direction of laps will allow water to be shed to outside of the *wall underlay*,
- c) Be lapped not less than 75 mm at horizontal joints,
- d) Be lapped not less than 150 mm over *studs* at vertical joints, and
- e) Extend 35 mm below bottom plate or bearer,
- f) Be restrained from bulging into a *drained cavity*. Refer to Paragraph 9.1.8.5.

9.1.7.2 Rigid *wall underlays*, in association with *drained cavities* (including *direct fixed* corrugated profiled metal), are required in Extra High *wind zones*. Refer to Table 3 and Table 23. Rigid *underlays* are also required to *external walls* of attached garages that are unlined. Refer Paragraphs 1.1.1 and 9.1.3.4 c).

Rigid *wall underlays* shall be in accordance with Table 23, and shall:

- a) Be minimum 7 mm H3 plywood, or 6 mm fibre cement sheet
- b) Be installed with sheet edges fixed over solid framing
- c) Be over-fixed with a flexible *wall underlay* from Table 23 and installed as in Paragraph 9.1.7.1

COMMENT:

Some proprietary systems may not require the addition of a flexible *underlay*

- d) Have flexible *underlay* folded into opening reveals as in Paragraph 9.1.5 a)
- e) Have *cavity battens* at maximum 600 mm centres
- f) Be *finish flushed* with underside of bottom plate or bearer.

Amend 5
Aug 2011Amend 5
Aug 2011Amend 5
Aug 2011Amend 5
Aug 2011Amend 5
Aug 2011Amend 5
Aug 2011Amend 5
Aug 2011Amend 5
Aug 2011Amend 5
Aug 2011Amend 5
Aug 2011

COMMENT:

External air pressures in higher *wind zones* can transfer to interior linings, and exceed recommended loadings prescribed by some *lining* manufacturers. Rigid *underlays* will protect *linings* from undue air pressure loadings, and help ensure cavity depths are maintained for the proper functioning of the *drained cavity*.

Amend 5
Aug 2011

9.1.8 Drained cavities

Based on the *risk score* for an *external wall* calculated as per Paragraph 3.1, a *wall cladding* may require the inclusion of a *drained cavity*. Where a *drained cavity* is required, it shall meet the requirements of Paragraphs 9.1.8 to 9.1.9.4.

Amend 2
Jul 2005

COMMENT:

Cavities manage occasional ingress of water past the *cladding*, but should not act as gutters or drains.

9.1.8.1 Limitations

This Acceptable Solution is limited to systems where:

- a) *Cavity battens* are fixed, by the *cladding* fixings, to the *wall framing*,
- b) *Claddings* are fixed through the *cavity battens* into the *wall framing*, and
- c) The *drained cavity* behind *claddings*, except in *masonry veneer*, is not vented at the top.

Systems where the *cladding* is fixed into the *cavity batten* only are outside the scope of this Acceptable Solution.

9.1.8.2 Requirements

Where a *drained cavity* is required, it shall:

- a) Be installed over a *wall underlay*, either flexible or rigid, that:
 - i) complies with Table 23, and
 - ii) is fixed to *wall framing*,
- b) Be formed using vertical *cavity battens*,
- c) Restrict air movement between the *drained cavity* and:
 - i) floor, *wall* and *roof framing*,
 - ii) attic *roof* space, and
 - iii) subfloor space,
- d) Be drained and open to the exterior at the bottom of cavities,
- e) Use vermin-proofing at the cavity base as per Paragraph 9.1.8.3 and Figure 66,

Amend 5
Aug 2011

Amend 2
Jul 2005

Amend 2
Jul 2005

Figure 66: Cavity base closer/vermin proofing
Paragraph 9.1.8.2

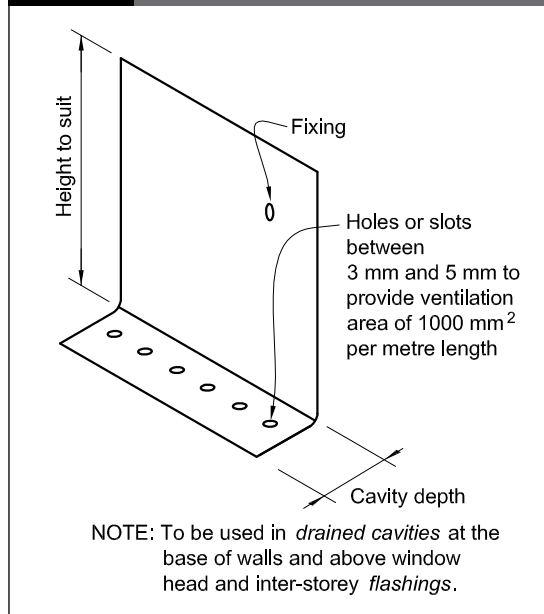

Amend 5
Aug 2011

Figure 67: Cavity spacers
Paragraphs 9.1.8.2 and 9.1.8.4

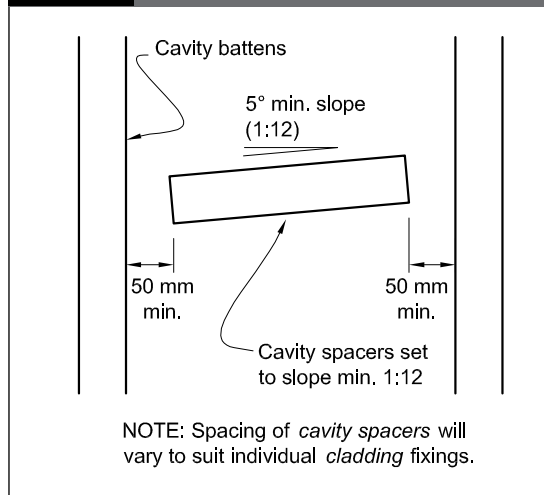

Amend 5
Aug 2011

- f) Use *cavity spacers* as shown in Figure 67, where fixing is required between *cavity battens*. Alternative *cavity spacers* to those described in Paragraph 9.1.8.2 are permitted. Refer to Paragraph 9.1.8.4 f).

Amend 5
Aug 2011

COMMENT:

Solid horizontal *cavity spacers* risk obstruction of air flow in cavities and risk bridging moisture across the *cavity*.

Amend 5
Aug 2011

9.1.8.3 Vermin-proofingAmend 5
Aug 2011

Vermin-proofing shall be provided above window and door heads and at the base of the *drained cavity*. Figure 66 provides one example of an appropriate cavity closer.

Amend 5
Aug 2011

Aluminium, stainless steel or uPVC in accordance with Paragraph 4.1 shall be used where vermin-proofing material is not readily accessible or replaceable.

Vermin-proofing shall:

Amend 2
Jul 2005

- a) Provide holes or slots between 3 mm and 5 mm,
- b) Provide an area of opening of 1000 mm² per lineal metre of *wall*, and
- c) Be positioned to allow a minimum *drip edge* to the *wall cladding* of:
 - i) 10 mm at the base of *walls*, and
 - ii) 15 mm above window and door head *flashings*.

COMMENT:

It is important the openings in vermin-proofing are kept clear and unobstructed in order to maintain draining and venting of the cavity. The closure shown is only one option for vermin-proofing. Provided openings are as specified, other dimensions can vary, so allowing the use of other shapes such as channels and right-angles.

Errata 2
Dec 2011**9.1.8.4 Cavity battens and jamb battens**

Cavity battens shall:

Amend 2
Jul 2005

- a) Be nominal 20 mm (between limits of 18 mm and 25 mm in thickness),
- b) Be a minimum 45 mm wide,
- c) Be fixed, by the *cladding* fixings, through the *wall underlay* into the *framing*,
- d) If timber, comply with B2/AS1,
- e) If polystyrene, comply with Paragraph 9.9.3.1, and be protected from any incompatible vapours from timber treatment.

Amend 5
Aug 2011

Cavity battens and/or cavity spacers that meet E2/VM1 Class 1 testing and B2/AS1, permit air circulation are allowed. The Class 1 test must include a horizontal *cladding* joint supported on a cavity spacer batten of a proposed type.

Amend 5
Aug 2011

Jamb battens shall:

Amend 5
Aug 2011

- f) be nominal 20 mm (between limits of 18 mm and 25 mm in thickness), minimum 45 mm wide, and of timber complying with B2/AS1. Refer to Figure 72A.

Errata 2
Dec 2011**COMMENT:**

The solvents from freshly LOSP-treated timber may melt polystyrene, so these should not be used together.

Solid horizontal cavity spacers risk obstruction of air flow in cavities and risk bridging moisture across the cavity.

Battens will be fixed by the *cladding* fixings, which will penetrate the *wall framing*. Battens will therefore need only temporary fixing until the *cladding* is fixed. Polystyrene battens may be temporarily adhered to the *wall underlay*.

Amend 5
Aug 2011Amend 5
Aug 2011**9.1.8.5 Wall framing behind cavities**

Dwangs shall be at a maximum of 1350 mm centres generally and maximum 480 mm centres for *direct-fixed* vertical weatherboard profiles, and vertical metal corrugated and symmetrical *trapezoidal claddings*.

Where *stud* spacings are greater than 450 mm, and flexible *wall underlays* only are used, an intermediate means of restraining the flexible *wall underlay* and insulation from bulging into the *drained cavity* shall be installed. Acceptable means of achieving this are by using:

- a) 75 mm galvanized mesh or wire galvanized in accordance with AS/NZS 4534,
- b) Polypropylene tape or galvanized wire at 300 mm centres fixed horizontally and drawn taut, or
- c) Vertical cavity battens at 300 mm centres maximum.

Amend 5
Aug 2011**9.1.9 Penetrations****9.1.9.1 Penetrations through cavities**

Window penetrations through cavities shall meet the requirements of Paragraph 9.2 to Paragraph 9.9.

9.1.9.2 Other cavity penetrations

Where penetrations of the *wall cladding* are wider than the *cavity batten* spacing, allowance shall be made for air flow between adjacent cavities by leaving a minimum gap of 10 mm between the bottom of the vertical *cavity batten* and the *flashing* to the opening.

9.1.9.3 Pipes and service penetrations

Pipes and service penetrations shall be made *weathertight* by using methods shown in Figures 68 and 69. *Flashing* tape complying with Paragraph 4.3.11, and sealant complying with:

- a) Type F, Class 20LM or 25LM of ISO 11600, or
- b) low modulus Type II Class A of Federal Specification TT-S-00230C.

Amend 5
Aug 2011

Figure 68: General pipe penetration
Paragraph 9.1.9.3, Figure 126

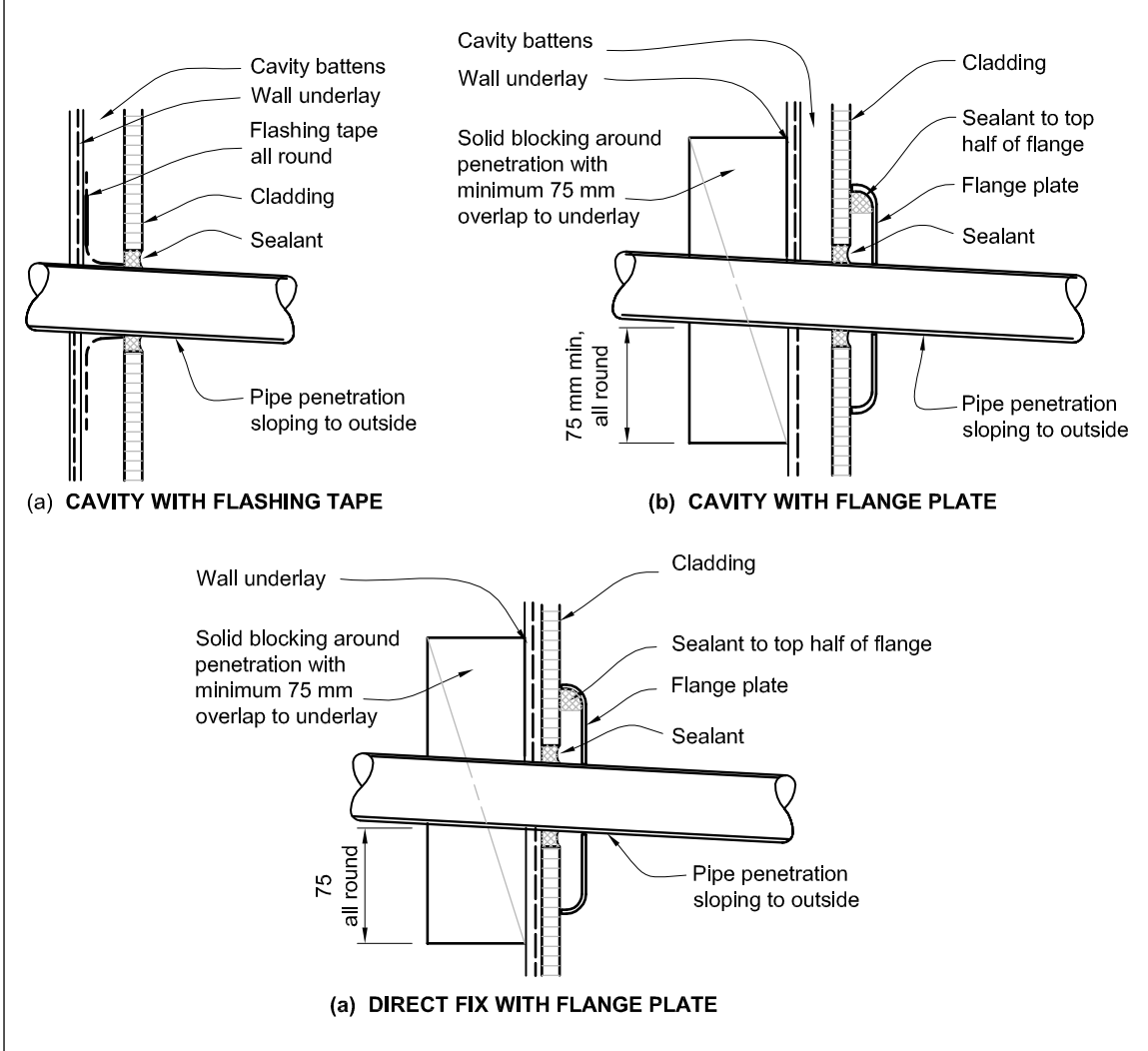

Amend 5
Aug 2011

Amend 5
Aug 2011

COMMENT:

Where possible, pipe penetrations, meterboxes and similar penetrations should be located in sheltered areas of the *building*, such as a porch, or be installed behind a weatherproof glazed panel.

Amend 5
Aug 2011

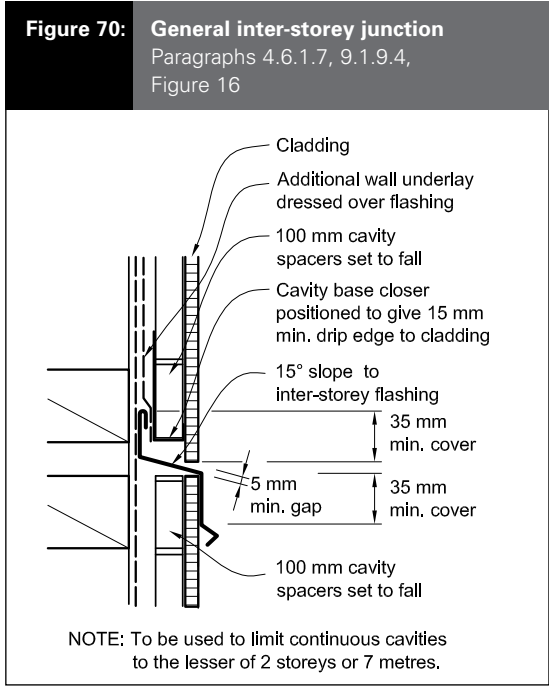
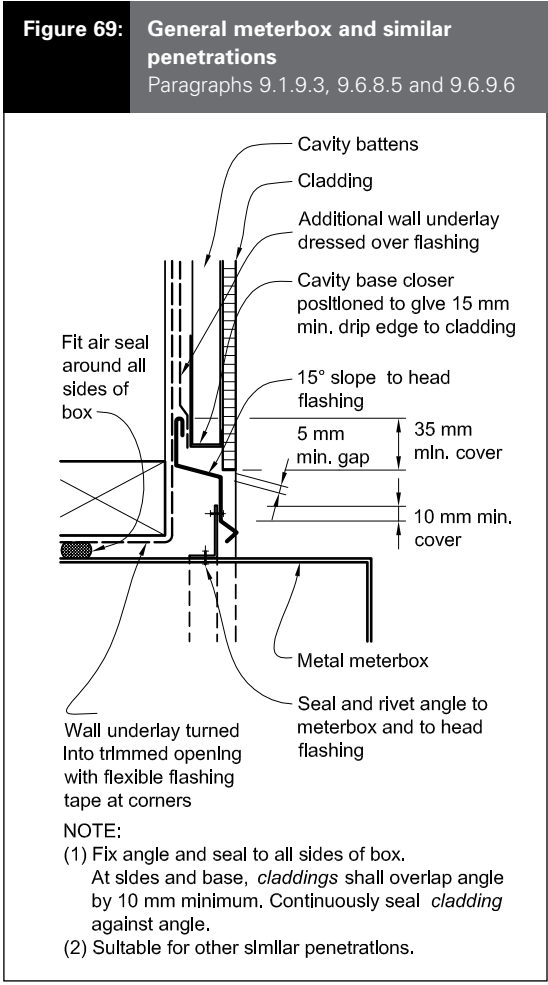

9.1.9.4 Inter-storey junctions

Inter-storey junctions in *claddings* over *drained cavities* shall be formed for *walls*:

Amend 5 Aug 2011

- a) Up to a maximum of two storeys or 7 metres in height, as shown for the specific *wall claddings* in Paragraph 9.2 to Paragraph 9.9, or

Amend 5 Aug 2011

- b) Over two storeys or 7 metres by using an inter-storey *flashing* bridging the *drained cavity* as shown in Figure 70.

COMMENT:

A *drained cavity* height is limited to manage the moisture handled by the cavity before it is directed to the outside.

Amend 5 Aug 2011

9.1.10 Windows and doors

Windows and doors shall comply with the requirements of NZS 4211, and reveals shall comply with NZS 3602. *Flashings* shall comply with Paragraph 4.0. Window details specific to particular *claddings* are given in Paragraph 9.2 to Paragraph 9.9. Door details shall be based on window details and shown in Figures 17A–D.

Amend 5 Aug 2011

After installation, the flange forming the window or door facing shall have an overlap to the surrounding *cladding* material or associated back *flashings* of

- a) For jambs – 10 mm minimum
- b) For sills – 8 mm minimum.

Amend 5 Aug 2011

9.1.10.1 Scope

This Acceptable Solution is limited to aluminium window and door joinery that:

- a) Has horizontal window and door heads only
- b) Has maximum frame dimensions of 5000 mm wide or 5000 mm high, and a maximum overall frame area, for any one frame, of 13.5 m², or
- c) For sills to floor level, has maximum width of 6 m and maximum overall frame area is 16 m².

Amend 5 Aug 2011

Amend 2 Jul 2005

COMMENT:

Sloped heads require specifically designed *kick-out flashings* at bottom edges of head flashings.

Where width outlined in Paragraph 9.1.10.1 are beyond the limits for sill and head trimmer *framing* in NZS 3604 specific engineering design of the *framing* is required.

Certain aluminium joinery sections and installation requirements may not be able to meet the details of this Acceptable Solution, especially in regard to window facing cover, sill support, window fixing, and sill *flashing* requirements. The window details in these cases require *specific design*.

Amend 5
Aug 2011

9.1.10.2 Treatment of opening

- a) Treatment of the window openings for *direct fixed wall claddings* shall be as shown in Figure 72A.
- b) For *direct fixed claddings*, windows and doors shall have a 5 mm stand-off of the flange to the *cladding* to allow for air intrusion to the trim cavity for pressure equalisation. Note that this gap is sealed or trimmed down the jambs, but left open along the sill.
- c) Window openings for *wall claddings over drained cavities* shall be as shown in Figure 72B. Note there shall be no *sill flashing*.
- d) For cavity fixed *claddings*, windows and doors shall finish against the *cladding*, except for flat fibre cement and ply *claddings* that require a 5 mm stand-off to allow for sealant weather seals between facings and *cladding* – eg, Figure 116.
- e) Materials for *flashings* shall be selected from Paragraph 4.0, Table 7, and Table 20.

9.1.10.3 Window and door heads

Windows and doors shall include head *flashings*, finished to the *wall underlay* as shown in Figure 71, by either using *flexible flashing tape*, or lapping an additional layer of *wall underlay* over the upstand. The additional *wall underlay* shall extend to the top of the wall, or to the nearest lap above, and be lapped under the top layer.

Amend 5
Aug 2011

Figure 71: General sealing of head flashing
Paragraphs 9.1.7, 9.1.10.3 and 9.1.10.4

NOTE: May also use *wall underlay* lapped over flashing upstand in lieu of *flexible flashing tape*. Refer cladding window details, for example Figure 115.

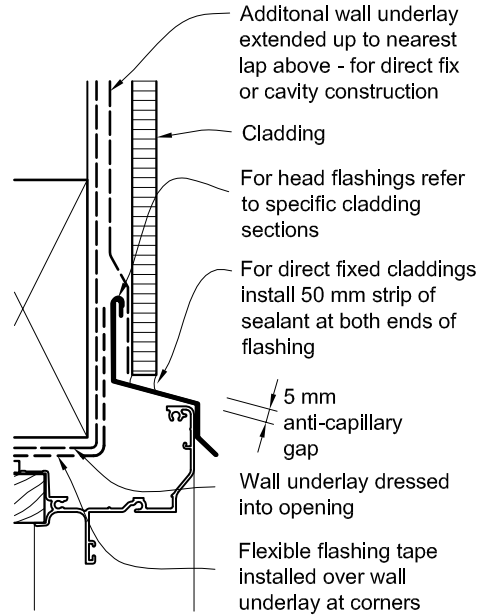

(a) METAL HEAD FLASHING - WITH ADDITIONAL UNDERLAY OPTION

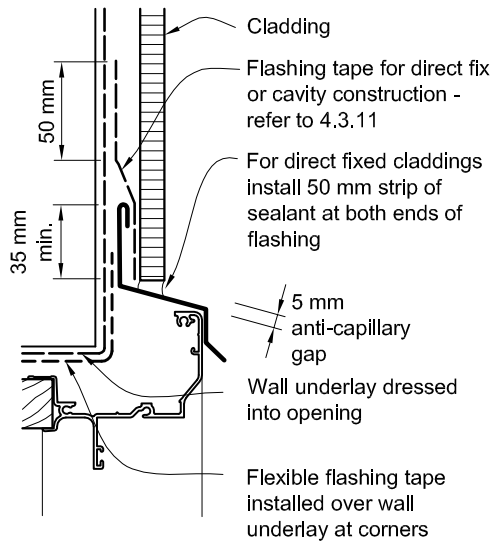

(b) METAL HEAD FLASHING WITH FLASHING TAPE OPTION

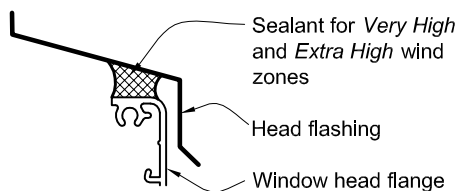

(c) METAL HEAD FLASHING SEALANT FOR VERY HIGH AND EXTRA HIGH WIND ZONES

Amend 5
Aug 2011

9.1.10.4 Head flashings

Head *flashings* shall be in accordance with Paragraph 4.6.1.6 and Table 7, unless specifically shown otherwise, and shall:

- a) Direct water to the outside of the *wall cladding*, and
- b) Finish to the window head with clearance dimensions shown in Figure 71
- c) For *direct fixed claddings*, have 50 mm bead of sealant installed between *cladding* and each end of the head *flashing*
- d) For *wall claddings on cavity walls*:
 - i) incorporate 10 mm turn-ups as *stop-ends*, terminating at the inside face of the *cladding* so they do not pass through the *cladding*, and
 - ii) permit ventilation of the *drained cavities* above, by the installation of cavity base closers as shown in Figure 66.
- e) For Very High and Extra High *wind zones*, have sealant installed between underside of head *flashing* and top edge of window head flange – refer Figure 71 (c) .

COMMENT:

Stopends are useful to prevent water moving past the ends of head *flashings*. However, additional problems of weatherproofing occur where the *stopend* penetrates the *cladding*.

9.1.10.5 Window and door sills

- a) *Direct fixed claddings* shall have
 - i) sill tray *flashings* as shown in Paragraphs 9.2 to 9.9 for each *cladding* type. The sill *flashing* shall extend back past the condensation channel of the window. Ensure flat sill trays do not slope backwards. The 5 mm gap between the window facing and sill tray must not be sealed.
 - ii) *direct fixed* door sills, installed as for windows, and as shown in Figure 17D.
- b) *Claddings over a drained cavity* shall have:
 - iii) window sills as shown in Paragraphs 9.2 to 9.9, without sill *flashings*
 - iv) door sills as shown in Figure 17C.

- v) Sill support bars and mechanisms for all doors, and for windows with a trim opening wider than 600 mm. Support bars and mechanisms shall comply with BRANZ Evaluation Method EM6, E2/VM1 and B2/AS1. Support bars and mechanisms must be installed prior to installation of the window or door.

COMMENT

Support bars and mechanisms are rated for their capacity to support the total weight of a joinery unit when installed at given offsets from the frame depending on *cladding* type. Designers select the an appropriate complying support mechanism for the joinery weight. Manufacturers provide build-in instructions for support bars and mechanisms.

- c) Mitred aluminium window and door sills, for both *cavity* and *direct fixed*, shall have a corner soaker fitted to the back of the sill/jamb joint and installed at point of manufacture. The soaker will be designed to act as a secondary device to prevent water ingress to the *building* in support of the primary mitre seals. Soaker materials shall be either uPVC, aluminium, polypropylene, high impact styrene or other semi rigid moulded polymeric material.

Sill support bars and mechanisms must be designed to not impede the possible drainage of water from surfaces of sill *flashing* tape, and permit an air passage (of at least 1000 mm²/m sill width) from the *drained cavity* to the window/door trim cavity.

9.1.10.6 Window and door jambs

Jamb *flashings* shall be installed as shown in Paragraphs 9.2 to 9.9.

Where required, jamb *flashings* shall overlap sill *flashings*, and direct moisture to the outside face of the *cladding system*.

Amend 5
Aug 2011

Amend 5
Aug 2011

Amend 5
Aug 2011

9.1.10.7 Closed cell foam tape

Compressible foam tape shown behind window facings and *cladding* joints shall be closed cell PVC foam, with:

- a) Hardness 55-60 to ASTM D2240 Scale OO,
- b) Grade VE-43 to ASTM D1667,
- c) Compression set of 20% maximum to ASTM D1667, and
- d) UV weathering in UV Weatherometer for 1500 light hours to ASTM G154 or ASTM G155 with no visible deterioration in appearance.

9.1.10.8 Attachments for windows and doors

Install windows and doors using pairs of minimum 75 x 3.15 galvanised jolt head nails or 8 gauge x 65 mm stainless steel screws, through reveals into surrounding *framing* at:

- a) Maximum 450 mm centres along sills, jambs and heads, and
- b) Maximum 150 mm from reveal ends.

Install packers between reveals and *framing* at all fixing points, except between head reveals and lintels.

Amend 5
 Aug 2011

Figure 72A: General window and door opening for direct fixed
 Paragraphs 9.1.5, 9.1.10.2, Figures 81, 82, 83, 84, 90, 95 and 115

NOTE:

- (1) Detailed *cladding* omitted for clarity, refer to specific *claddings*.
- (2) Sill *flashing* shall extend back past the condensation channel of the window.
- (3) Head to be treated similarly with continuous *building underlay* and *flexible tape* at corners.
- (4) Refer individual *cladding* details for jamb *flashings* and sill tray return requirements

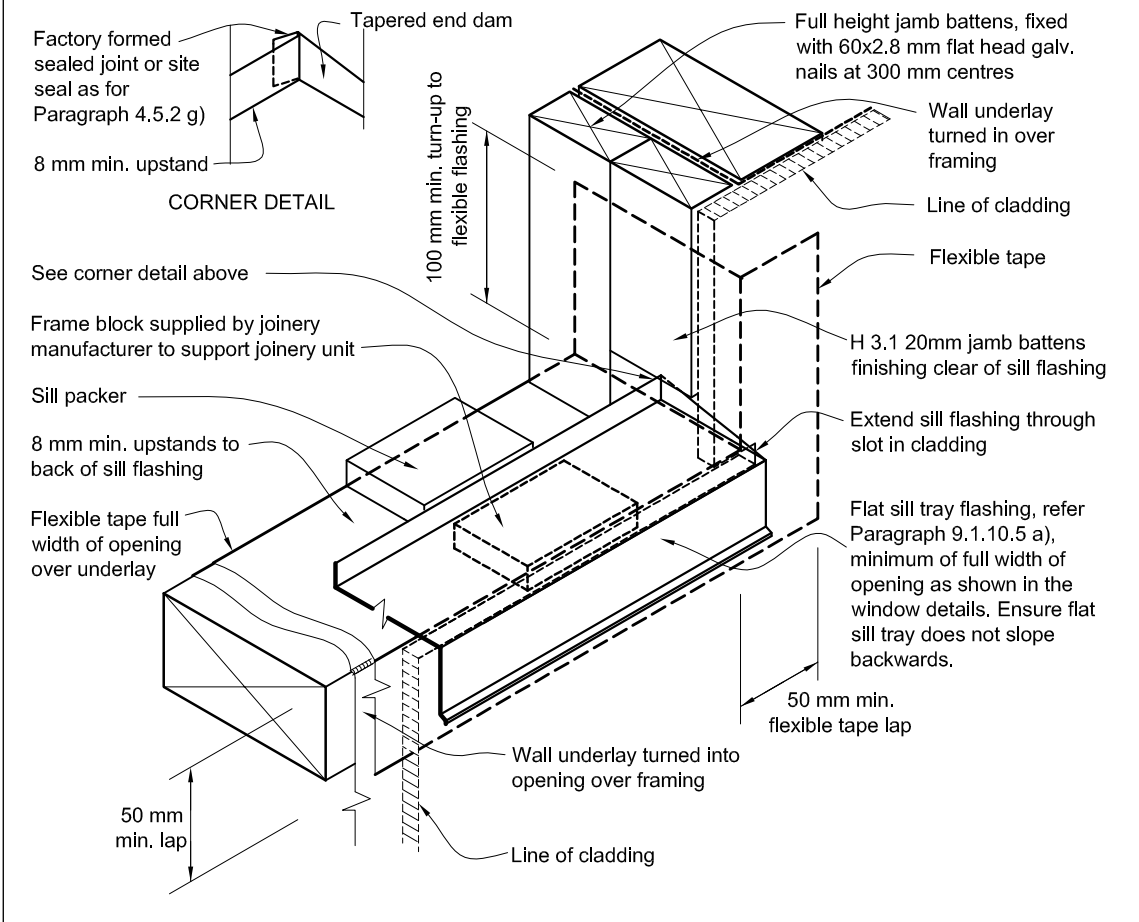

Errata 2
 Dec 2011

Amend 5
 Aug 2011

Figure 72B: General window and door opening with drainage cavity
 Paragraphs 9.1.5, 9.1.9.3, 9.1.10.2, Figures 73C, 76, 85, 86, 91, 99, 116 and 128

NOTE:
 (1) Detailed *cladding* omitted for clarity, refer to specific *claddings*.
 (2) Head to be treated similarly with continuous *wall underlay* and *flexible tape* at corners.
 (3) Refer individual cladding details for jamb flashings.

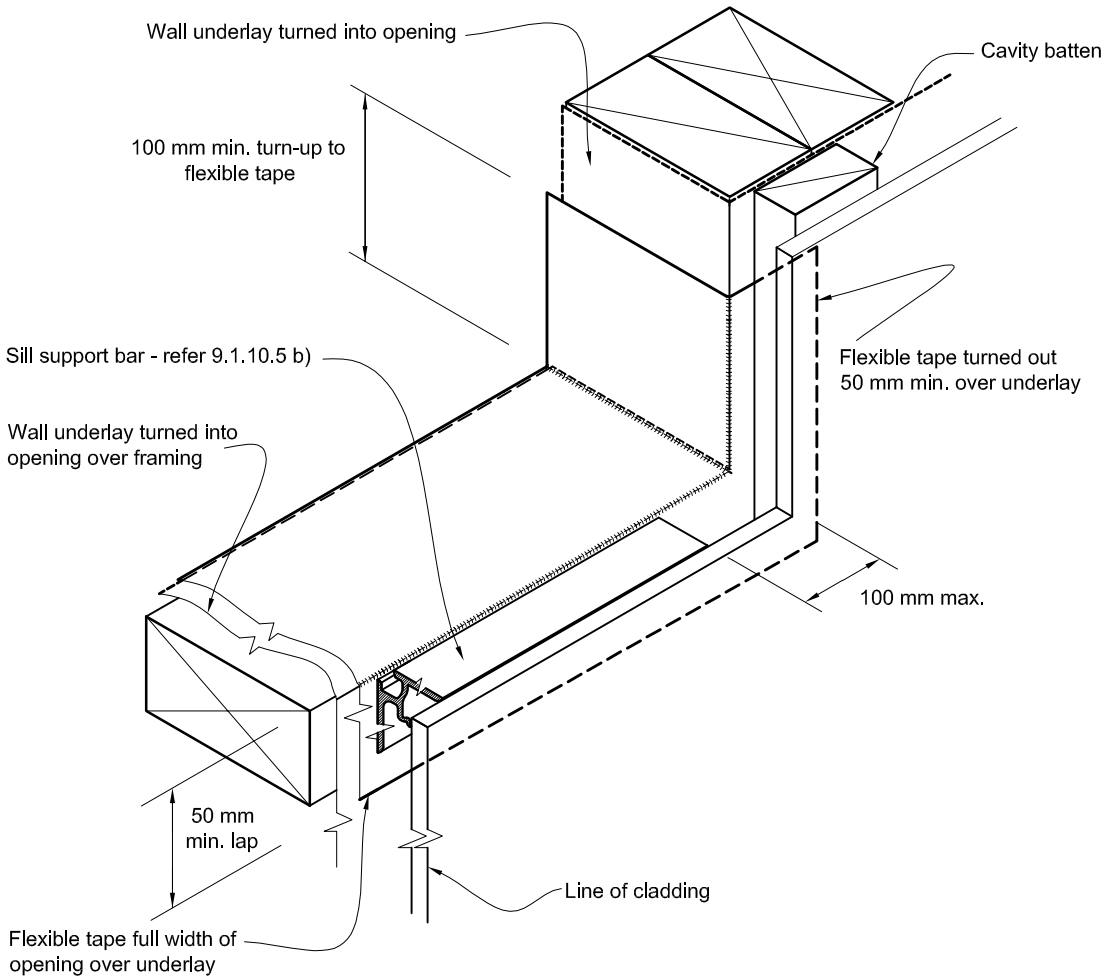

Errata 2
 Dec 2011

Amend 5
 Aug 2011

9.2 Masonry Veneer

9.2.1 Limitations

This Acceptable Solution is limited to *masonry veneer cladding* attached to *timber wall framing* outlined in NZS 3604. *Masonry veneer* is either:

- a) Clay brick, or
- b) Concrete brick or block.

COMMENT:

Natural stone bricks or blocks may be suitable. However, they are not part of this Acceptable Solution. Refer to the manufacturer’s recommendations for *specific design* information.

Refer to Paragraph 1.5 for qualification of installers.

9.2.2 General

- 1) The materials and workmanship of *masonry veneer* shall be in accordance with SNZ HB 4236 and have a maximum mass of veneer of 220 kg/m² and minimum veneer thickness of 70 mm
- 2) Masonry units shall be laid-up in running bond
- 3) Mortar, materials (cement, sand and admixtures) shall comply with NZS 4210
- (4) Mortar joints less than 24 hours old shall not be subject to vibration, such as would result from the nailing of interior *linings*

9.2.3 Installation

Masonry veneer construction shall be as shown in Figure 73B, and have:

- a) A maximum height of veneer above adjacent *finished ground level* of 7 m.
- b) A maximum height of veneer of 4.0 m, measured from the top of the concrete *masonry wall*, *foundation wall* or slab edge foundation. In the case of a veneer faced concrete block *wall* or *foundation wall* height is measured from the top of that *wall*.
- c) A maximum height of veneer of 5.5 m on a gable end *wall*.
- d) A minimum *wall* or panel width of 230 mm.

Note: The bracing demand for framing supporting *masonry veneer* is determined from values listed in NZS 3604.

COMMENT:

Refer to Paragraph 1.5 for qualification of installers

9.2.4 Flashings

- 1) Sill and head *flashings* shall be as described in Paragraph 4.3 and be either:
 - a) 1.5 mm butyl rubber– refer to Paragraph 4.3.9
 - b) 2 ply asphaltic pliable *waterproofing membrane* – refer to Paragraph 4.3.10
 - c) Pliable polyethylene minimum 0.5 mm thick complying with DPC/DPM Table 23.
- 2) Jamb *flashings* shall be:
 - d) 2 ply asphaltic pliable *waterproofing membrane* complying with AS/NZS 2904
 - e) Pliable polyethylene minimum 0.5 mm thick complying with DPC/DPM Table 23.

COMMENT:

For further information refer to ASTM C1330 for backing rod material performance.

Errata 2
Dec 2011

Amend 5
Aug 2011

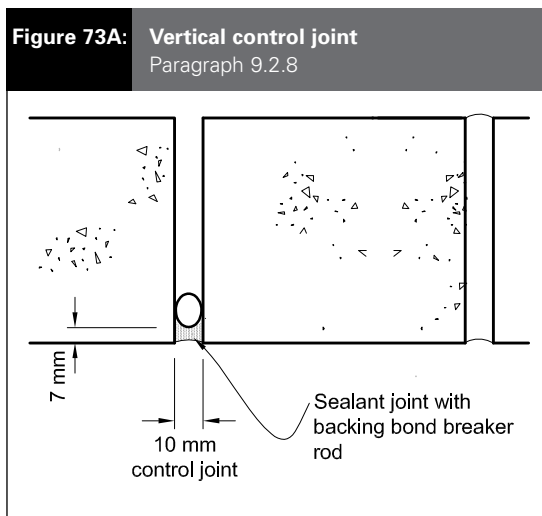

Amend 5
Aug 2011

Errata 2
Dec 2011

Amend 5
Aug 2011

Figure 73B: Masonry veneer height limitations
Paragraph 9.2.3

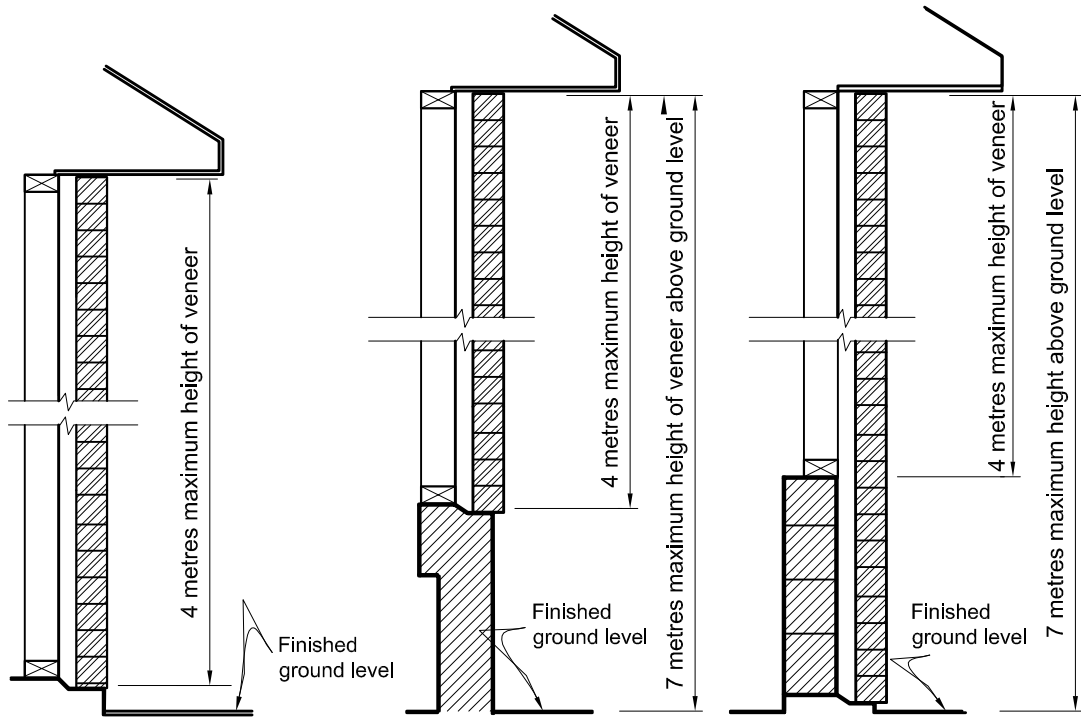

(a) 1 STOREY

(b) 2 STOREY ON MASONRY

(c) 2 STOREY VENEER

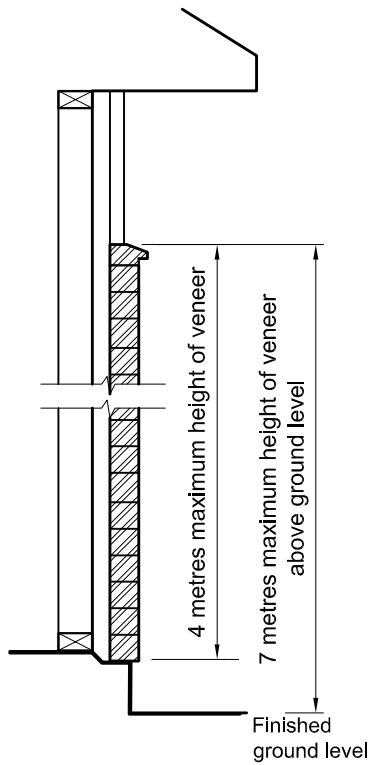

(d) 1 STOREY WITH PART STOREY

Amend 5
Aug 2011

Figure 73C: Masonry veneer window and door installation
 Paragraphs 9.2.4, 9.2.6 and 9.2.9

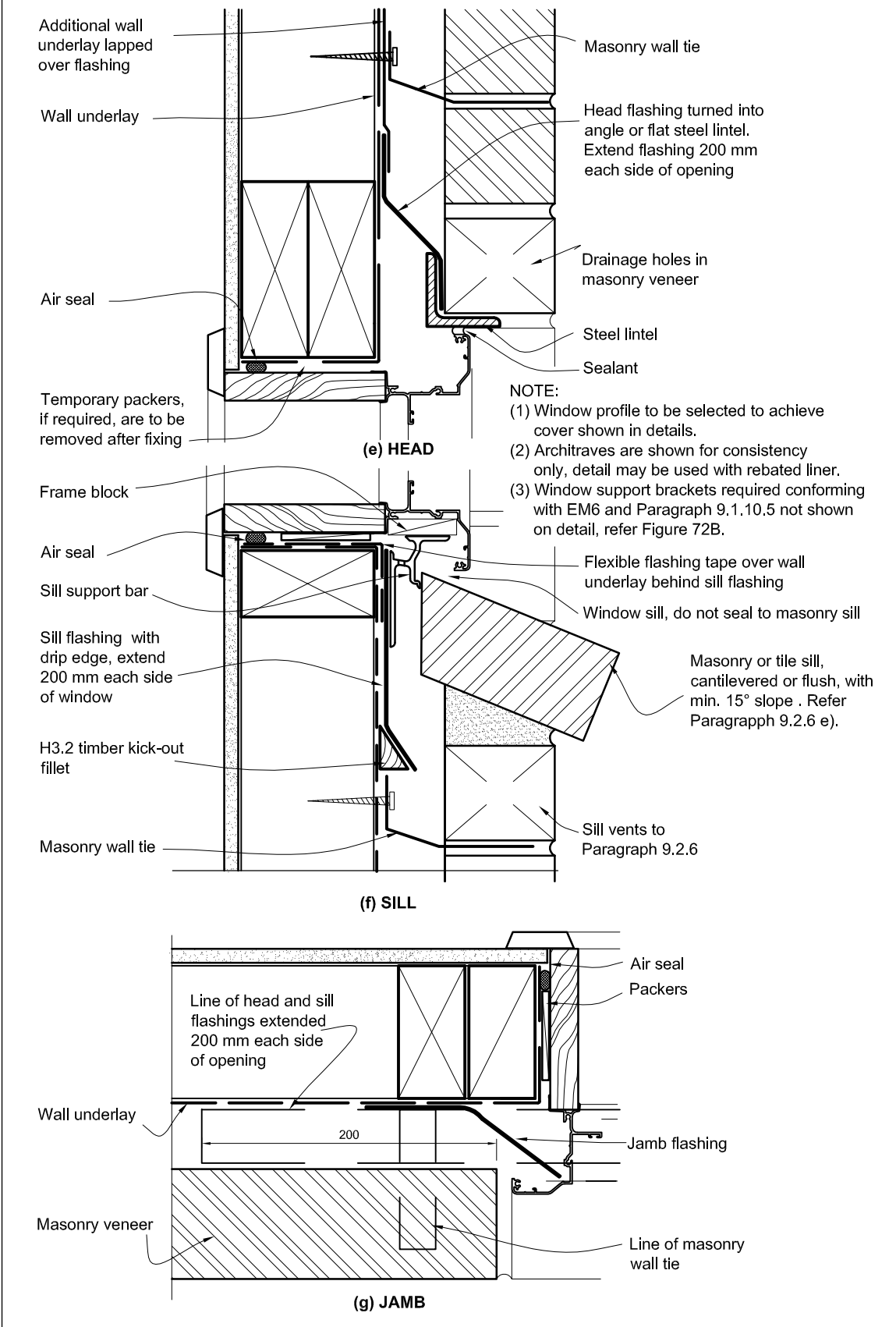

Errata 2
 Dec 2011

Errata 2
 Dec 2011

Amend 5
 Aug 2011

Figure 73D: Masonry veneer details
Paragraph 9.2.5

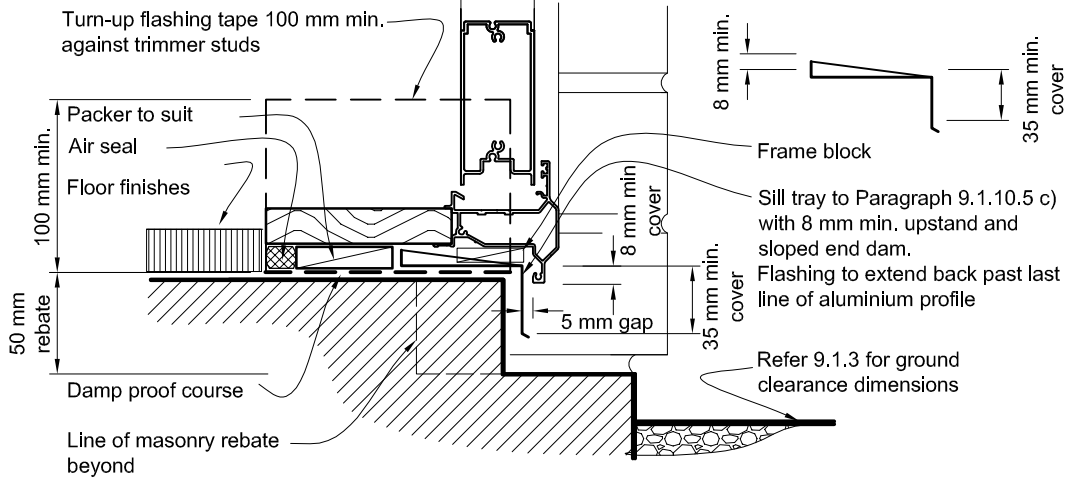

(h) MASONRY VENEER - DOOR SILL

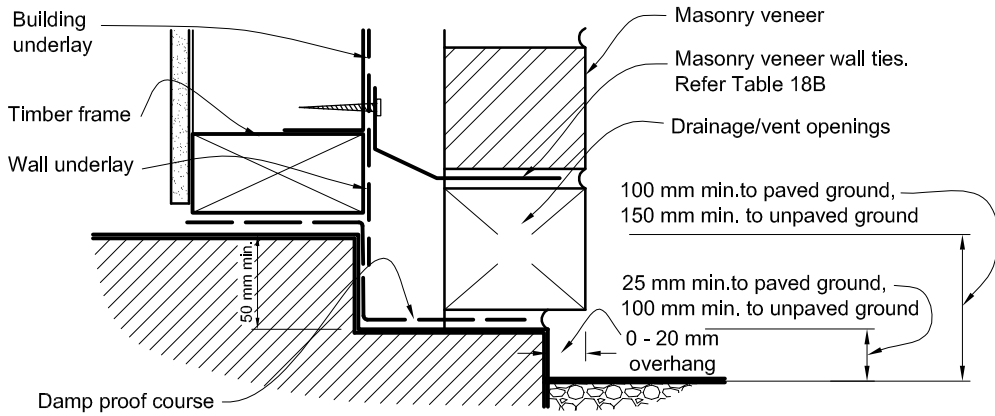

(i) MASONRY VENEER - FLOOR REBATE DETAIL

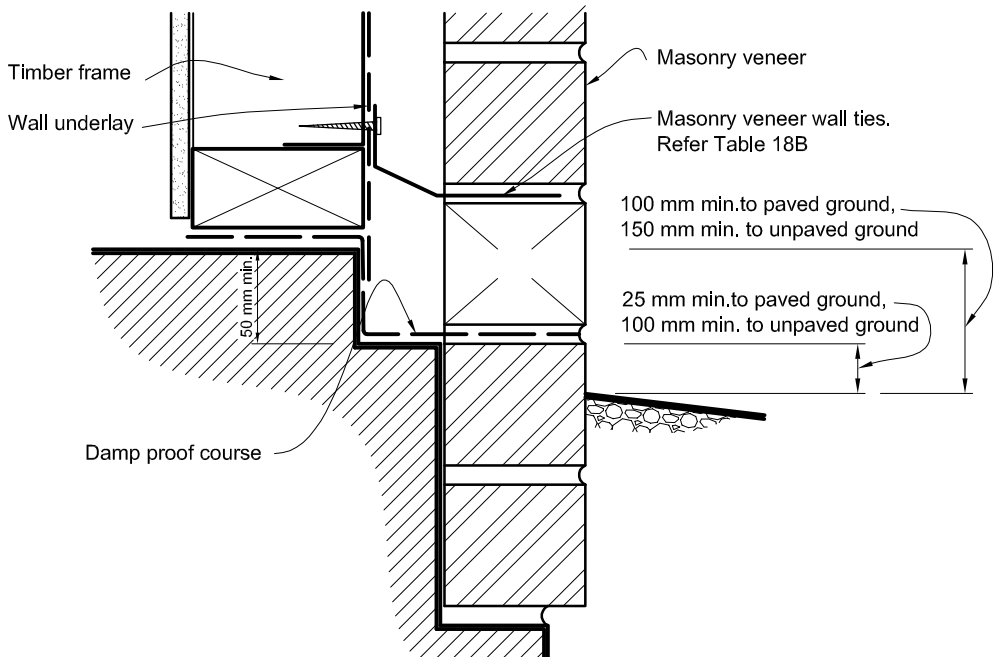

(j) MASONRY VENEER - MASONRY BELOW GROUND

Errata 2
Dec 2011

Errata 2
Dec 2011

Errata 2
Dec 2011

Amend 5
Aug 2011

Figure 73E: Masonry veneer details
Paragraphs 9.2.5 and 9.2.6

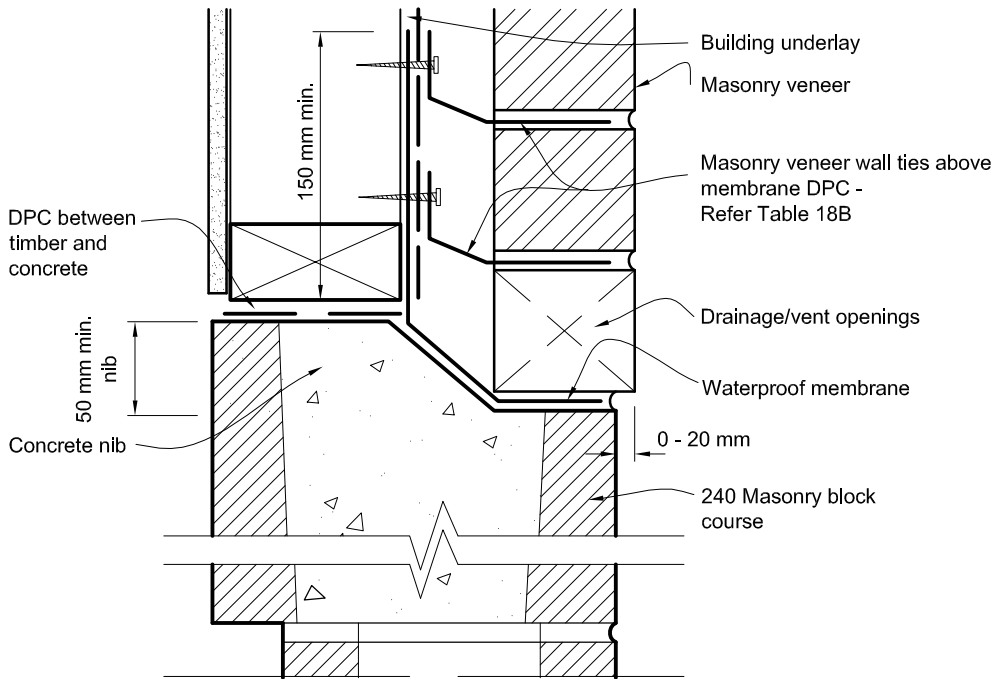

(k) MASONRY VENEER - ABOVE GROUND SUPPORT

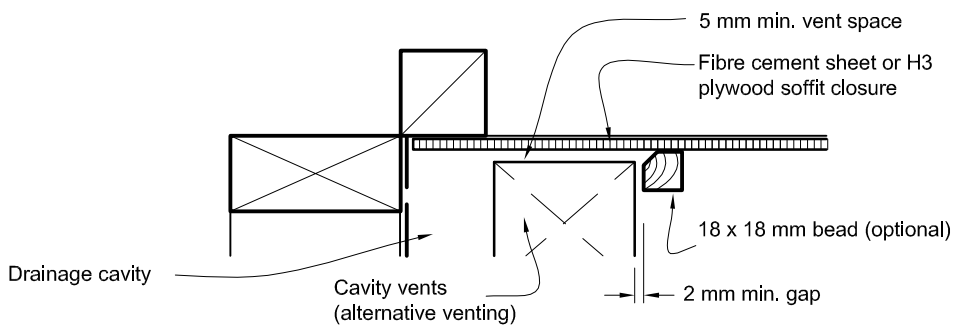

(l) MASONRY VENEER - SOFFIT DETAIL

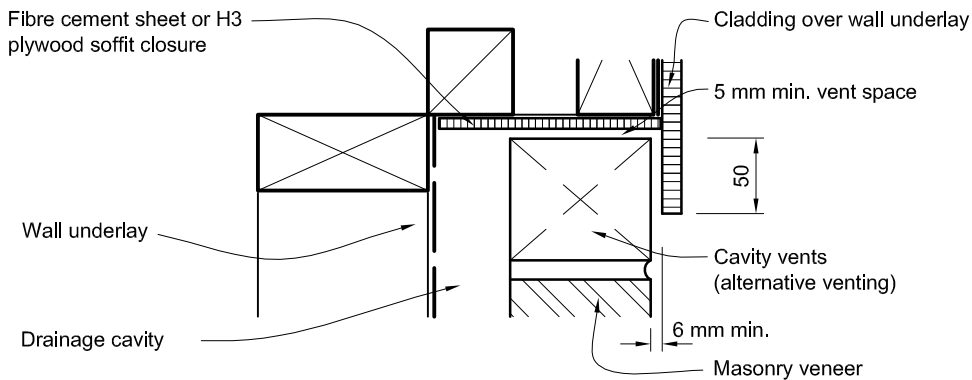

(m) MASONRY VENEER - CANTILEVER UPPER FLOOR

Errata 2
Dec 2011

Errata 2
Dec 2011

Errata 2
Dec 2011

Errata 2
Dec 2011

Amend 5
Aug 2011

9.2.5 Foundation support and damp proofing

- 1) *Masonry veneer* shall be supported by one, or a combination of the following:
 - a) Concrete of masonry foundation *wall*
 - b) Thickened slab edge footing
 - c) Concrete or masonry lower storey *wall*.
- 2) The level of the concrete slab above ground shall comply with Figure 65.
- 3) The top of a foundation wall or concrete slab shall be stepped down, so that the surface supporting the veneer is 50 mm or more below the surface supporting the timber *framing*.
- 4) Provide a *damp-proof course* to the stepped rebates supporting *masonry veneer* adjacent to all habitable spaces and garages attached to habitable spaces. This includes stepped rebates in foundations, or on top of concrete or concrete masonry *walls* supporting veneers. Damp-proofing material shall be as outlined in Table 23 and be either:
 - a) For rebates lower than ground floor level:
 - i) two coats of bituminous liquid, or
 - ii) 1.0 mm butyl rubber or bituminous sheet, or
 - iii) 0.25 mm polythene or polyethylene *damp-proof membrane*.
 - b) For rebates above ground floor level:
 - i) 1.0 mm butyl rubber or bituminous sheet, or
 - ii) 0.25 mm polythene or polyethylene *damp-proof membrane*.
- 5) Lap joints in *flashings* minimum of 150 mm.
- 6) Dimension rebates to accommodate the required cavity width in Paragraph 9.2.6 and the thickness of the veneer so that the veneer is supported within the tolerances outlined in Figures 73D and E.

Amend 5
Aug 2011**9.2.6 Cavities**

Paragraphs 9.1.8.2(a), 9.1.8.5, and 9.1.9.3 shall apply to *masonry veneer* cavities.

- a) The clear width of cavity between the *masonry veneer* and the exterior face of the *wall underlay* or bracing attaching to timber *framing* shall not be less than 40 mm or more than 75 mm wide measured at any part of the cavity.

COMMENT:

It is important to maintain the minimum cavity width of 40 mm after allowing for construction tolerances and thicknesses of *wall underlays* and sheet bracing.

- b) Pipes and services shall not be placed in the cavity other than passing directly through the cavity to the exterior.
- c) The cavity shall be drained and vented to outside at the bottom of wall panels, and above openings by open perpend that:
 - i) are a minimum of 75 mm in height, by the width of the vertical mortar joint
 - ii) at centres not exceeding 800 mm (where drainage/weep holes are less than 75 mm high, decrease spacing to give a ventilation area of 1000 mm²/m wall length)
 - iii) are fitted with vermin proofing where gaps greater than 13 mm exist.
- d) The cavity shall be ventilated to the outside at the top of *walls* by either similar vents as at the bottom, or a continuous 5 mm minimum gap between the top course and soffit board, with a cover bead to outside that maintains a minimum 2 mm gap to masonry – refer to Figure 73E(l).
- e) The cavity shall be vented under openings exceeding 2.4 metres wide through gaps in perpend positioned at 1/3 points along the opening except at opening ends. Where these vent openings are used, protect from water entry using cantilevered sill bricks, as shown in Figure 73C (f).
- f) The cavity shall be sealed off from the floor and *roof* space.

Errata 2
Dec 2011Errata 2
Dec 2011Amend 5
Aug 2011

Table 18A: Specification of maximum tie spacings for type B (4) veneer ties
Paragraph 9.2.7

| Seismic zone | Masonry veneer Less than 180 kg/m ² | | | Masonry veneer 180 – 220 kg/m ² | | | Masonry veneer more than 220 kg/m ² |
|--------------|---|-----------------|---|---|---|-----|---|
| | Refer NZS 3604 | Tie type (4)(5) | Maximum spacings (1) Horizontal Vertical | Tie type (4)(5) | Maximum spacings (1) Horizontal Vertical | | |
| 1 | EL | 600 | 400 | EM | 600 | 400 | SED (2) |
| 2 (6) | EM | 600 | 400 | EH (3) | 600 | 400 | SED (2) |
| 3 | EH (3) | 600 | 400 | EH (3) | 600 | 400 | SED (2) |
| 4 | SED (2) | SED (2) | SED (2) | | | | |

NOTES

- (1) Maximum masonry tie spacings of 600 mm horizontally and 400 mm vertically
- (2) Spacing of ties to be determined by specific engineering design
- (3) EM may be used if the horizontal spacings do not exceed 400 mm and the vertical spacings do not exceed 300 mm
- (4) Type B and Prefix E indicate masonry ties manufactured to AS/NZS 2699.1
- (5) L (Light), M (Medium), H (High) indicate strength capability of ties in AS/NZS 2699.1
- (6) Use seismic zone 2 (minimum) for Christchurch region comprising Christchurch City, Waimakariri District and Selwyn District.

COMMENT:

Variations in cavity width will require compensating adjustments to the length of masonry tie used.

9.2.7 Wall ties

Masonry veneer shall be attached to *wall framing* by *wall ties*. *Wall ties* and their spacings and embedment shall be in accordance with the requirements of NZS 4210 and Tables 18A, 18B and 18C. Screw fixings shall be minimum 12 gauge, 35 mm long hex washer face, galvanised or stainless steel to suit the ties required under Table 18C.

Table 18B: Placement of wall ties
Paragraph 9.2.5 and 9.2.7

| Location | Placement of masonry ties |
|--|---|
| Unsupported panel sides and edges of openings | Within 300 mm of panel side or edge. |
| Top of veneer panels and top of panels under openings | Within 300 mm or two courses (whichever is the smaller) of top of veneer |
| Bottom of veneer panel in masonry rebate sealed with liquid applied <i>damp-proof course</i> | Within 300 mm or two courses (whichever is the smaller) from bottom of veneer |
| Bottom of veneer panel supported on steel angle lintel | |
| Bottom of veneer panel in masonry rebate with <i>membrane damp-proof course</i> | In each of the first two courses |

NOTES:

Ties are to be screw fixed (ie. non-impact method) using screws outlined in Table 24.

9.2.7.1 Wall ties and screws shall be determined by the *durability* zone outlined in NZS 3604 and as outlined in Table 18C.

Table 18C: Corrosion protection to masonry wall ties
Paragraph 9.2.7

| | 316, 316L, or 304 stainless steel | 470 g/m ² galvanising on mild steel |
|---------------|-----------------------------------|--|
| Zone B | Yes | Yes |
| Zone C | Yes | Yes |
| Zones D and E | Yes | - |

Errata 2
Dec 2011

9.2.8 Control joints

9.2.8.1 Clay bricks

Control joints in clay brick *masonry veneer* are not required, unless specified by the brick manufacturer.

9.2.8.2 Concrete bricks

Longitudinal shrinkage stresses in concrete *masonry veneer* shall be controlled by providing vertical *control joints* at not more than 6 m centres.

Vertical control joints shall be located:

- Within 600 mm of T joints
- Within 600 mm of L shaped corners or by restricting the spacing to the next *control joint* to 3.2 m maximum
- At changes in *wall* height, exceeding 600 mm
- At changes in *wall* thickness.

Amend 5
Aug 2011

Control joints shall be formed as shown in Figure 73A and comprise:

- A backer rod of compressible foam, and
- Sealant in compliance with:
 - Type F, Class 20LM or 25LM of ISO 11600, or
 - low modulus Type II Class A of Federal Specification TT-S-00230C.

9.2.9 Openings in masonry veneer

Openings with *masonry veneer* above shall be spanned by steel angle lintels.

Openings in *masonry veneer* for meter boxes less than 500 mm wide may be installed without lintel bars or head *flashings* provided the meter box is sealed to *wall underlay* with flashing tape to Paragraph 4.3.11.

Separate steel meter boxes from direct contact with *masonry veneer* or mortar with flashing tape to Paragraph 4.3.11.

Lintels shall:

- Be protected against corrosion as in Table 18D and to exposure zones outlined in NZS 3604.
- Have a minimum seating into adjacent veneer of:
 - 100 mm for spans up to, and including 2 m,
 - 200 mm for spans over 2 m.
- Be sized in accordance with Table 18E.

Table 18D: Corrosion protection to lintels
Paragraph 9.2.9, Table 18E

| | 316 or 316L or 304(2) stainless steel or 600 g/m ² galvanising on mild steel plus duplex coating(1) | 600 g/m ² galvanising on mild steel(1) or 300 g/m ² galvanising on mild steel plus Duplex coating(1) |
|--------|--|--|
| Zone B | Yes | Yes |
| Zone C | Yes | Yes |
| Zone D | Yes | |

1) To AS/NZS 2699.3
2) 304 stainless steel will exhibit greater levels of surface rusting than 316 stainless steel, especially where not exposed to rain washing.

Amend 5
Aug 2011

Table 18E: Masonry veneer lintel sizes (minimum)
Paragraph 9.2.9

| Span of lintel (m) up to: | Maximum thickness of masonry veneer (mm) | | | | | |
|------------------------------|--|-----------------|-----------------|----------------|-----------------|-----------------|
| | 70 | | | 90 | | |
| | Maximum height of veneer supported (mm) | | | | | |
| | 350 | 700 | 2000 | 350 | 700 | 2000 |
| 0.800 | 60 x 60 x 6 L | 60 x 60 x 6 L | 60 x 60 x 6 L | 60 x 80 x 6 L | 60 x 80 x 6 L | 80 x 80 x 6 L |
| 2.000 | 60 x 60 x 6 L | 60 x 60 x 6 L | 60 x 60 x 6 L | 60 x 80 x 6 L | 60 x 80 x 6 L | 80 x 80 x 6 L |
| 2.500 | 60 x 60 x 6 L | 80 x 80 x 6 L | 80 x 80 x 6 L | 80 x 80 x 6 L | 80 x 80 x 6 L | 80 x 80 x 6 L |
| 3.000 | 80 x 80 x 6 L | 80 x 80 x 6 L | 125 x 75 x 6 L | 80 x 80 x 6 L | 80 x 80 x 8 L | 90 x 90 x 10 L |
| 3.500 | 80 x 80 x 6 L | 80 x 80 x 6 L | 125 x 75 x 6 L | 80 x 80 x 8 L | 90 x 90 x 10 L | 125 x 75 x 10 L |
| 4.000 | 80 x 80 x 8 L | 125 x 75 x 6 L | 125 x 75 x 10 L | 80 x 80 x 10 L | 125 x 75 x 6 L | 150 x 90 x 10 L |
| 4.500 | 125 x 75 x 6 L | 125 x 75 x 10 L | – | 125 x 75 x 6 L | 125 x 75 x 10 L | – |
| 4.800 | 125 x 75 x 6 L | 125 x 75 x 10 L | – | 125 x 75 x 6 L | 125 x 75 x 10 L | – |

Amend 5
Aug 2011**9.2.10 Windows and doors**

The openings in *wall framing* for windows and doors shall have *flexible flashing tape* applied, in accordance with Paragraph 9.1.5.

Air seals shall be provided in accordance with Paragraph 9.1.6.

Window *flashings* shall be installed in accordance with Paragraph 9.2.4 and Figures 73C and 73D(h).

Amend 5
Aug 2011**9.2.11 Secondary cladding**

Where a secondary *cladding* is used with the *masonry veneer*, and is *direct fixed* to *framing* above windows or at gable ends, this shall be fully sealed on:

- a) The face of the *cladding*,
- b) All edges of the *cladding*, and
- c) A 75 mm minimum perimeter strip on the rear of the *cladding*.

Amend 5
Aug 2011

9.3 Stucco

9.3.1 Limitations

This Acceptable Solution is limited to the following types of *stucco cladding*:

- a) Solid plaster *cladding* with a non-rigid backing and a *drained cavity*, and
- b) Solid plaster *cladding* with a rigid backing and a *drained cavity*. Refer to Figure 74

9.3.2 Structure

The timber *framing* of *external walls* supporting *stucco wall claddings* shall comply with NZS 3604 and NZS 4251. The *cladding system* shall be attached to the *wall framing*.

The *framing* for *buildings* using *stucco exterior cladding systems* shall be supported on a:

- a) Concrete slab-on-ground, or
- b) Continuous reinforced concrete foundation wall, or
- c) Reinforced concrete masonry foundation wall.

9.3.3 Stucco cladding system

All *stucco claddings* shall be used over a *drained cavity* as described in Paragraph 9.1.8, and shown in Figure 74.

9.3.3.1 All *stucco cladding* shall have *wall underlay* as specified in Table 23 and Paragraphs 9.1.5–9.1.7, and shall be:

- a) Fixed to the *framing* as specified in Table 23, and
- b) Provided as an overlay to rigid backings to provide a slip layer that permits the independent movement of plaster and backing.

9.3.3.2 Have plaster backing installed as in Paragraphs 9.3.5 and 9.3.6.

9.3.3.3 Have metal lath reinforcements for *stucco* plaster attached through the plaster backing as described in Table 24.

9.3.4 Installation

9.3.4.1 General

COMMENT:

Refer to Paragraph 1.5 for qualification of installers.

Activities that will cause impact or vibration during plaster application are not permitted until all plastering is completed and fully cured.

The materials, proportions, mixes, thickness, reinforcement materials and fixing, *control joints*, and application and curing of plaster shall comply with NZS 4251.

9.3.4.2 Movement control joints

Movement *control joints* shall be as required in NZS 4251.

Figure 74: Types of stucco cladding
Paragraphs 9.3.1 and 9.3.3

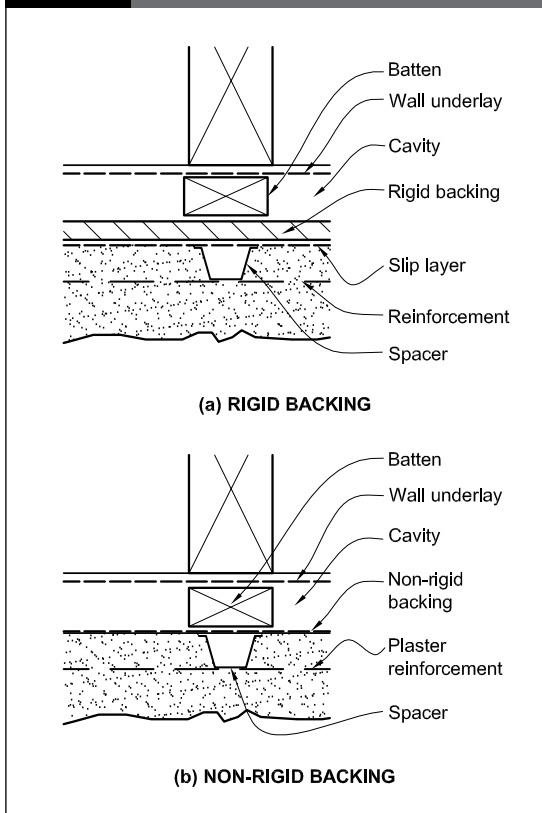

Amend 5
Aug 2011

Errata 2
Dec 2011

Amend 5
Aug 2011

Amend 5
Aug 2011

Amends
2 and 5

Amend 5
Aug 2011

9.3.5 Non-rigid plaster backings

9.3.5.1 Installation of wall underlays

The *wall underlay* shall be in accordance with Table 23, and as described in Paragraphs 9.1.5–9.1.7.

Amend 5
Aug 2011

9.3.6 Rigid plaster backings

Rigid backings shall be made of either:

- a) Plywood, or
- b) Fibre cement sheet, and
Have slip layers to Paragraph 9.3.3 b).

Amend 5
Aug 2011

Backing sheets shall be no more than 3 mm out of plane at the time of plastering.

9.3.6.1 Plywood backing

Plywood shall be:

- a) Selected from Table 6 of NZS 4251,
- b) H3 treated as per AS/NZS 2269, and
- c) Fixed as specified in Clause 4.2.4.4.2 of NZS 4251, except that nails shall:
 - i) be 2.8 mm in diameter, and
 - ii) penetrate *framing* by 35 mm minimum.

Amend 5
Aug 2011

Amend 2
Jul 2005

Amend 5
Aug 2011

9.3.6.2 Fibre cement sheet backing

Fibre cement shall:

- a) Comply with AS/NZS 2908: Part 2,
- b) Be a minimum of 4.5 mm thick,
- c) Span no more than 600 mm centres between *cavity battens*, and
- d) Be fixed as specified in Clause 4.2.4.5.2 of NZS 4251, except that nails shall:
 - i) be 2.8 mm in diameter, and
 - ii) penetrate *framing* by 35 mm minimum.

Amend 5
Aug 2011

COMMENT:

When the sheathing is used as bracing, the nailing patterns are subject to *specific design*, and the use of tested and rated systems.

Amend 2
Jul 2005

9.3.7 Finishes

All *stucco* surfaces shall be sealed by applying a minimum of a 2-coat latex exterior paint system complying with any of Parts 7, 8, 9 or 10 of AS 3730.

Amend 2
Jul 2005

COMMENT:

Stucco cladding systems cannot be assumed to be completely weatherproof.

It is necessary to ensure that corrosive salts are not carried into the plaster by moisture, causing corrosion of the reinforcing and fixings.

9.3.8 Bottom of stucco

The bottom of *stucco* wall *cladding* shall be in accordance with Paragraph 9.1.3, and as shown in Figure 75.

9.3.9 Parapets and enclosed balustrades

Parapets shall be in accordance with Paragraph 6.0.

Enclosed balustrades shall be in accordance with Paragraph 7.4.

Parapets and *enclosed balustrades* for *stucco cladding* shall be capped with metal, butyl or *EPDM membrane*, complying with the requirements of Paragraph 4.0.

9.3.10 Windows and doors

Windows and doors shall comply with Paragraph 9.1.10, as shown in Figure 76.

Amend 5
Aug 2011

Figure 75: Bottom of stucco cladding
Paragraph 9.3.8

NOTE: 6 mm offset of *framing* to foundation is not necessary where *drained cavities* are used.

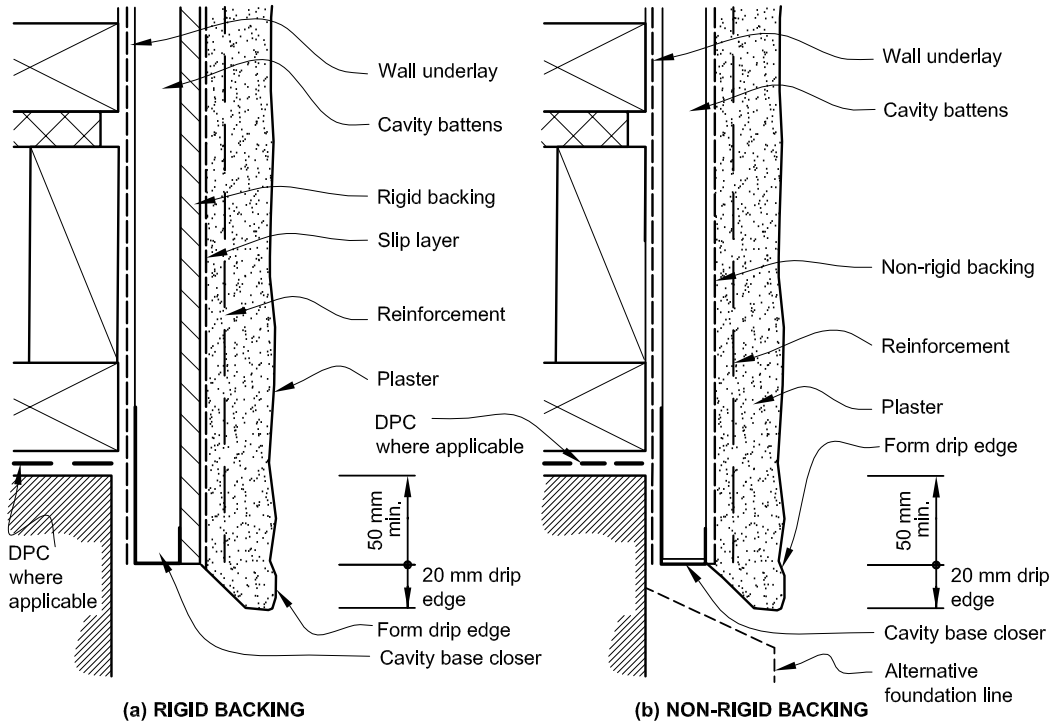

Amend 2
Jul 2005

Amend 5
Aug 2011

Figure 76: Windows and doors in stucco cladding
Paragraph 9.3.10, Figure 72B

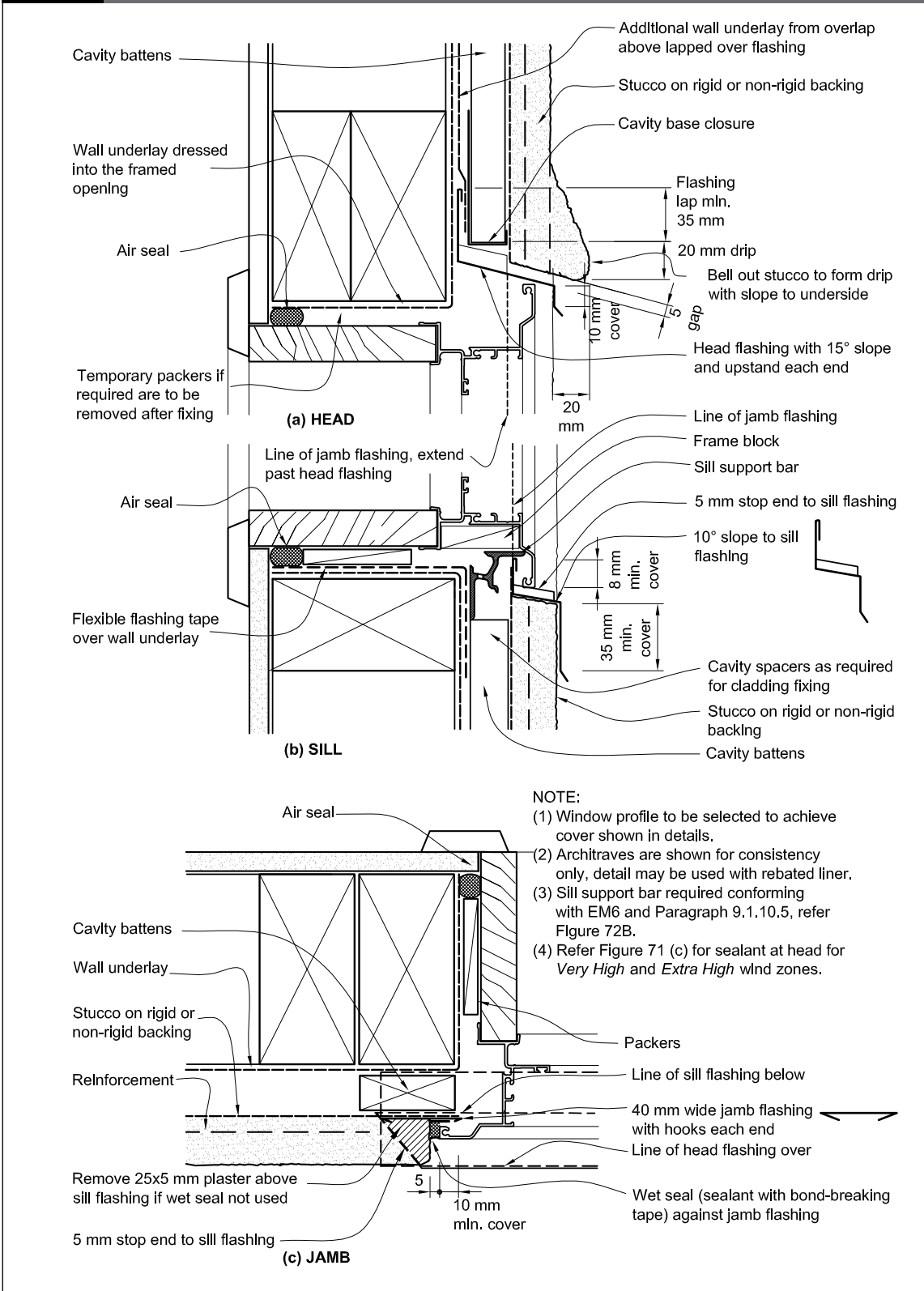

Amend 5
Aug 2011

9.4 Timber Weatherboards

Amend 5
Aug 2011

Timber weatherboard *claddings* shall be either *direct fixed* to *framing* over a *wall underlay* or fixed over a *drained cavity* as described in Paragraph 9.1.8.

Based on the *risk score* for an *external wall* calculated as per Paragraph 3.1, the weatherboard *cladding* may require the inclusion of a *drained cavity*.

9.4.1 Limitations

9.4.1.1 Weatherboard profiles

This Acceptable Solution is limited to the following types of timber weatherboards:

- Horizontal bevel-back,
- Horizontal rebated bevel-back,
- Horizontal rusticated,
- Vertical shiplap, and
- Vertical board and batten.

Profiles shall be as given in NZS 3617 or BRANZ Bulletin 411.

9.4.1.2 Vertical weatherboards

This Acceptable Solution is limited to the use of *direct fixed* vertical weatherboards in risk categories as shown in Table 3.

COMMENT:

Vertical weatherboards are not used over cavities because of the need for horizontal battens, which if solid would interfere with a *drained cavity*.

Vertical weatherboards are therefore limited to low risk applications.

Amend 5
Aug 2011

9.4.1.3 Horizontal weatherboards

Horizontal weatherboards shall be either *direct fixed* or fixed over a *drained cavity*, according to the risk categories as shown in Table 3.

9.4.2 Materials

Timber weatherboard *cladding* shall include the following features:

Amend 5
Aug 2011

- Wall underlay* complying with Table 23 and Paragraphs 9.1.5–9.1.7, and
- Timber selection and treatment of weatherboards in accordance with NZS 3602.

9.4.3 Installation

A *building underlay* complying with Table 23 shall be installed behind:

- All *direct fixed* timber weatherboards, or
- Cavity battens* for timber weatherboards installed over a *drained cavity*.

COMMENT:

Refer to Paragraph 1.5 for qualification of installers.

Amend 5
Aug 2011Amend 5
Aug 2011

9.4.3.1 Fixings

Fixings shall comply with Tables 20 and 24.

Timber weatherboards shall be drilled for nailing at all joints and ends. All cut ends of painted weatherboards shall be primed.

Amend 2
Jul 2005

9.4.4 Horizontal weatherboards

9.4.4.1 Horizontal laps

Laps shall be:

- 32 mm for non-rebated bevel-back boards, or
- 25 mm horizontal lap for rebated bevel-back and rusticated boards, with a minimum gap of 2 mm at the overlap between boards.

9.4.4.2 Joints

Joints shall be made only over supports and have:

- Corrosion-resistant soakers fitted, complying with Paragraph 4.3.2 to Paragraph 4.3.8, or
- Scarf or splay joints.

Amend 5
Aug 2011

9.4.4.3 Fixings

Boards shall be fixed through the *wall underlay* to the *framing* in accordance with Table 24.

Amend 5
Aug 2011

9.4.4.4 External corners

External corners shall be weatherproofed by one of the following methods:

- a) For rusticated and bevel-back weatherboards, corner boxes with:
 - i) scribes for bevel-back weatherboards, as shown in Figure 78, or
 - ii) plugs or scribes for rusticated weatherboards, as shown in Figure 78,
- b) For bevel-back weatherboards:
 - i) mitred joints with back *flashing* as shown in Figure 78, or
 - ii) mitred joints with corrosion-resistant soakers – refer to Paragraphs 4.3.2 to 4.3.6 and Figure 77.

9.4.4.5 Internal corners

Internal corners shall be made *weathertight* as shown in Figure 79. A corrosion-resistant *flashing* shall be fitted behind weatherboards at all internal corners as shown in Figure 79.

Amend 5
 Aug 2011

Amend 5
 Aug 2011

Figure 77: Corner soakers for bevel-back weatherboards
 Paragraph 9.4.4.4

NOTE: Soaker corner for *direct fixed* weatherboards is similar to Figure 88.

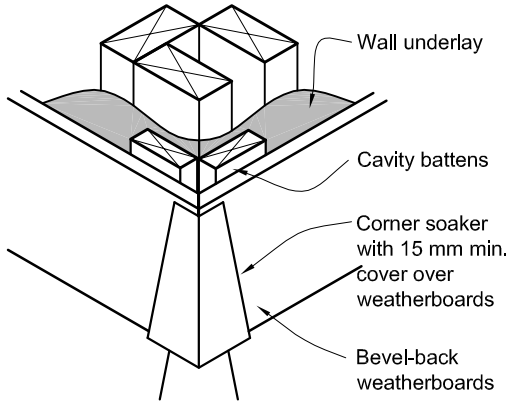

Amend 2
 Jul 2005

Amend 2
 Jul 2005

Amend 5
 Aug 2011

Figure 78: External corners for horizontal weatherboards
Paragraph 9.4.4.4

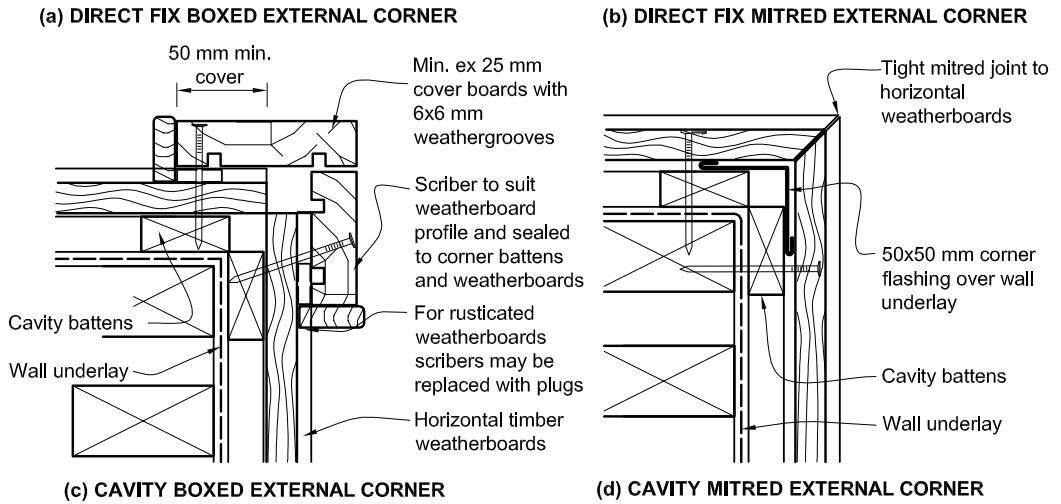
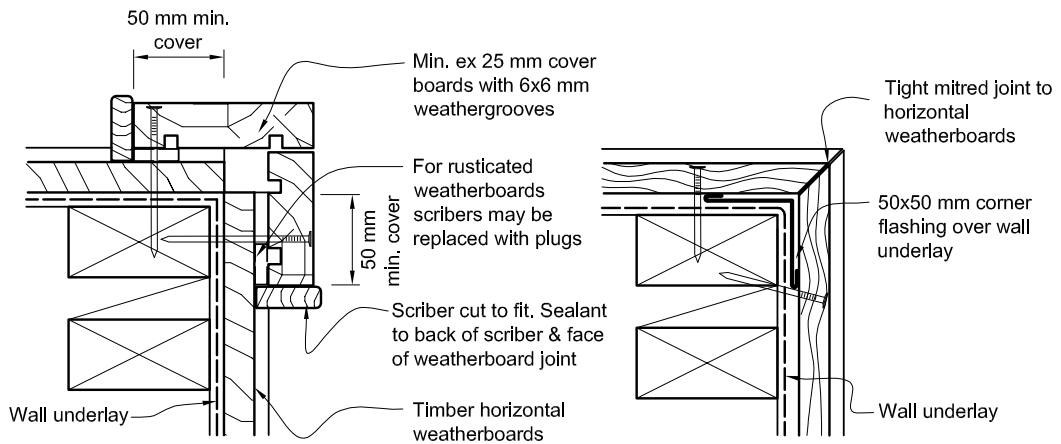

Amend 5
Aug 2011

Figure 79: Internal corners for horizontal or vertical weatherboards
Paragraph 9.4.4.5

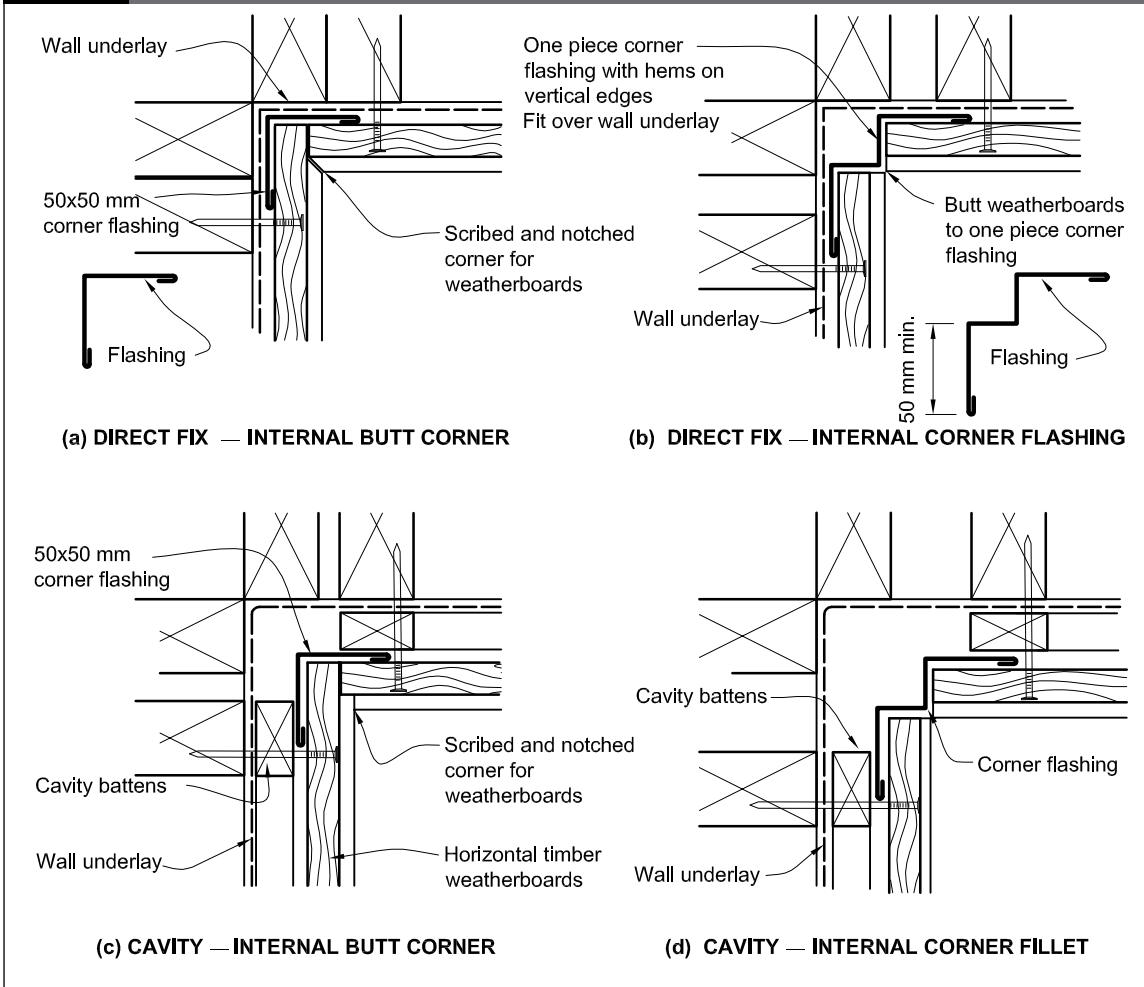

Amend 5
Aug 2011

9.4.5 Vertical weatherboards

Vertical shiplap and board and batten weatherboards shall be in continuous lengths over a storey height.

9.4.5.1 Laps

- a) Vertical shiplap weatherboards shall be fitted with a minimum gap of 2 mm at the overlap between boards.
- b) Board and batten weatherboards shall:
 - i) be fitted with a 5 mm to 8 mm gap between boards, and
 - ii) have weather grooves to boards and battens aligned.

9.4.5.2 Fixings

Vertical weatherboards shall be fixed to *dwangs* at 480 mm maximum centres in accordance with Table 24.

Amend 5
Aug 2011

9.4.5.3 Corners

a) External corners

External corners shall be weatherproofed by the use of corner facings as shown in Figure 80.

b) Internal corners

A corrosion-resistant corner *flashing*, as per Table 7 and Figure 79, shall be fitted behind the weatherboards at all internal corners.

Amend 5
Aug 2011

Amend 5
Aug 2011

9.4.6 Windows and doors in direct fixed weatherboards

Amend 5
Aug 2011

Window and door details for:

- a) *Direct fixed* bevel-back weatherboards are shown in Figure 81,
- b) *Direct fixed* rusticated weatherboards are shown in Figure 82,
- c) Vertical shiplap weatherboards are shown in Figure 83,
- d) Vertical board and batten weatherboards are shown in Figure 84.

Amend 5
Aug 2011

Door sill details are as shown in Figure 17D.

9.4.7 Windows and doors in cavity walls

Amend 5
Aug 2011

Window and door details for bevel-back weatherboards on a *drained cavity* shall be as shown in Figure 85.

Amend 5
Aug 2011

Window and door details for rusticated weatherboards on a *drained cavity* are shown in Figure 86.

Amend 5
Aug 2011

Door sill details are as shown in Figure 17C.

COMMENT:

The junctions around windows are critical, and it is important that responsibility is taken for the *weathertightness* of the window as installed within exterior walls.

Care should be taken to ensure that this responsibility is clearly defined and assigned. One way is to clearly specify that the window manufacturer shall be responsible for the supply and installation of *flashings* and frames into openings.

Figure 80: External corners for vertical weatherboards
Paragraph 9.4.5.3

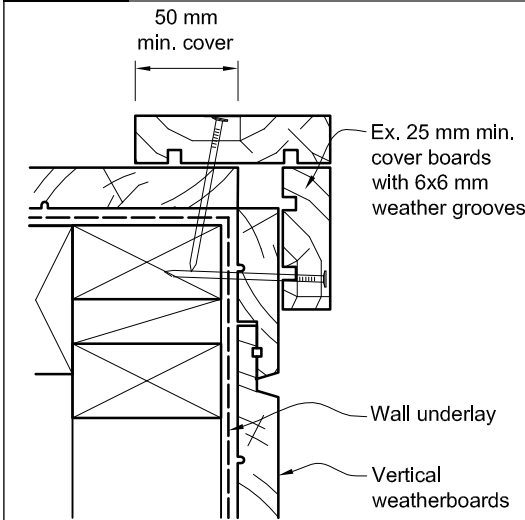

NOTE: Corner battens shall be sized to provide 50 mm minimum cover over *cladding*.

Amend 5
Aug 2011

Figure 81: Windows and doors for direct fixed bevel-back weatherboards
Paragraph 9.4.6

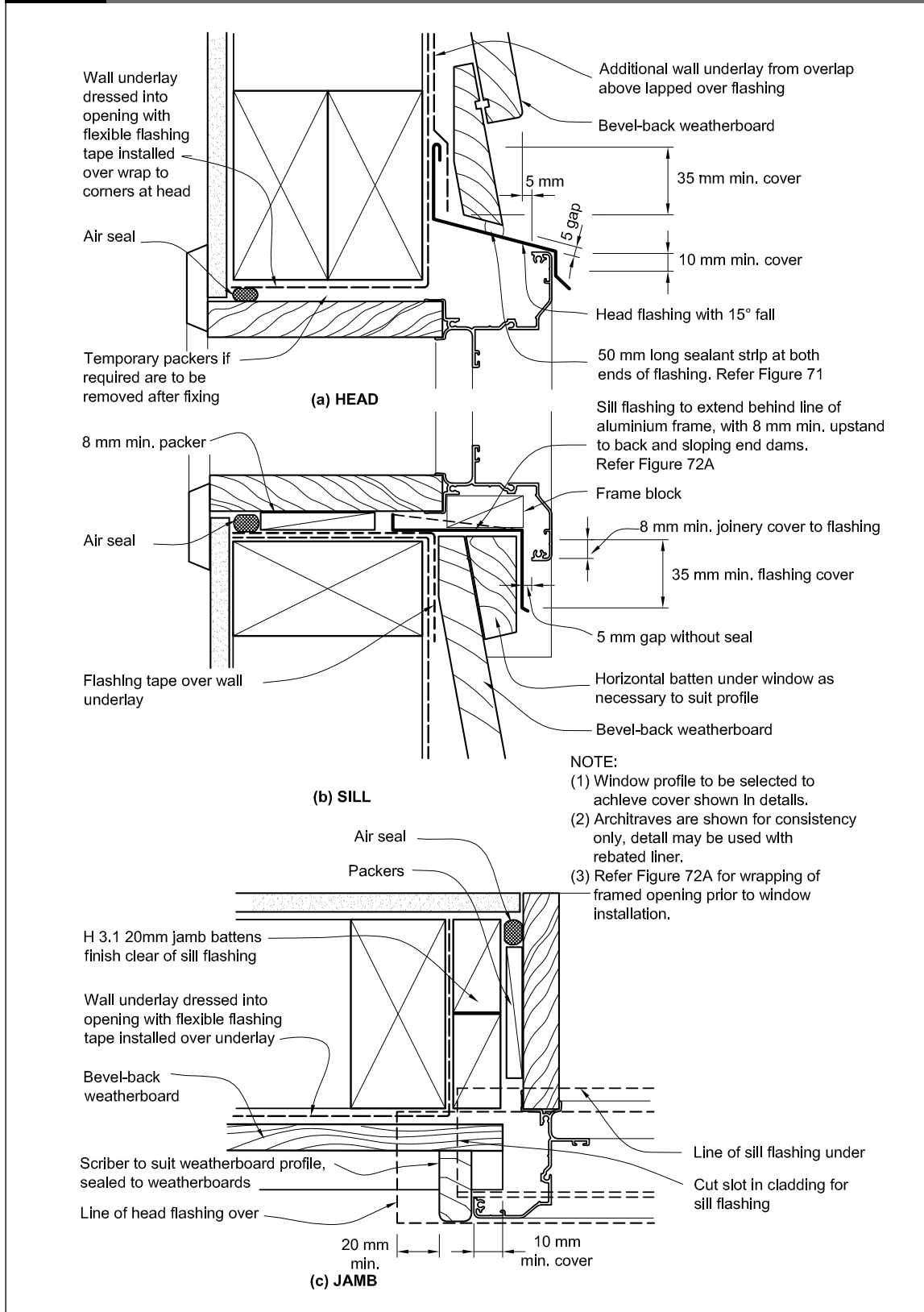

Amend 5
Aug 2011

Amend 2
Jul 2005

Figure 82: Windows and doors for direct fixed rusticated weatherboards
Paragraph 9.4.6

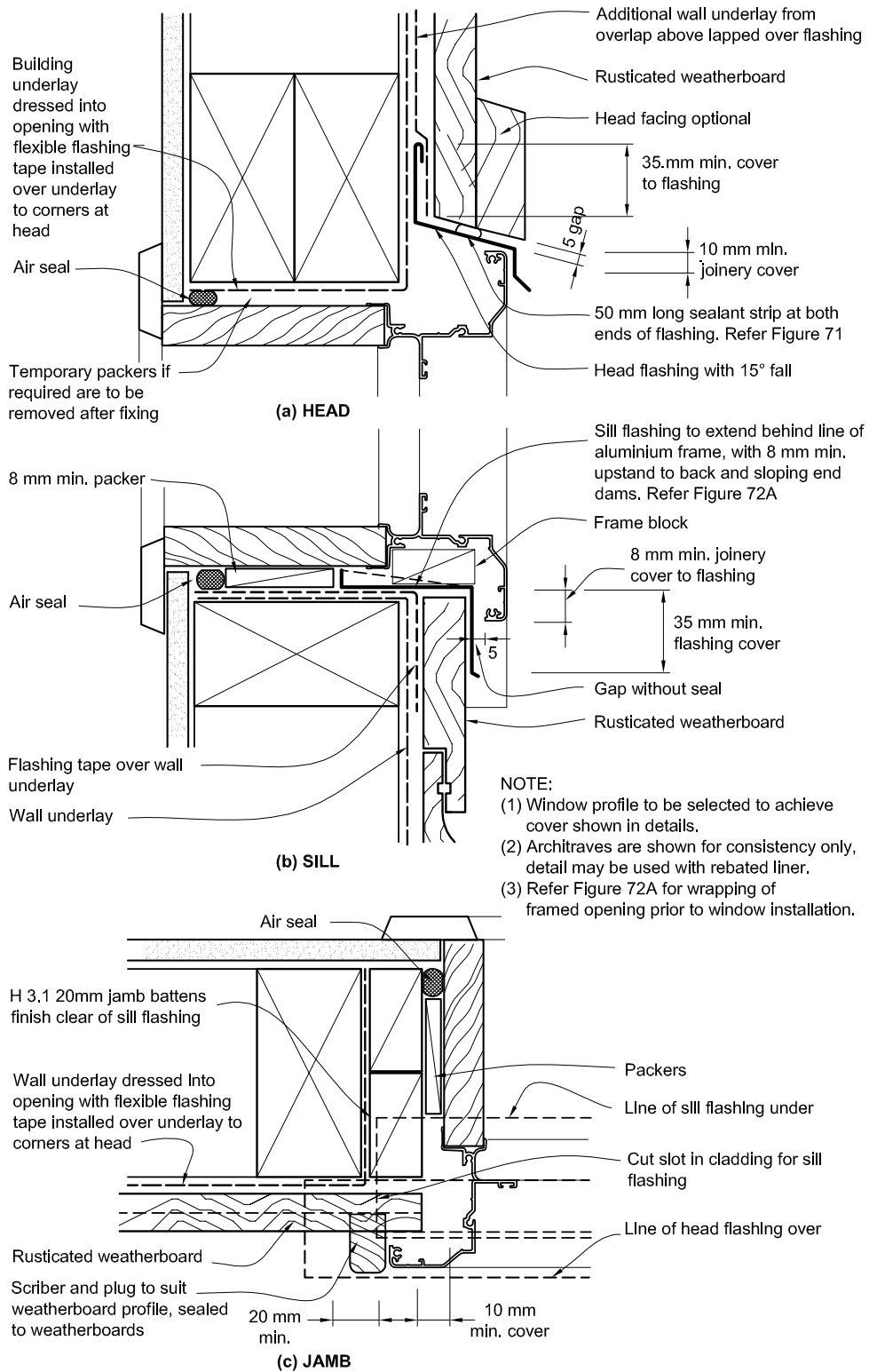

Amend 5
Aug 2011

Amend 2
Jul 2005

Figure 83: Windows and doors for direct fixed vertical shiplap weatherboards
Paragraph 9.4.6

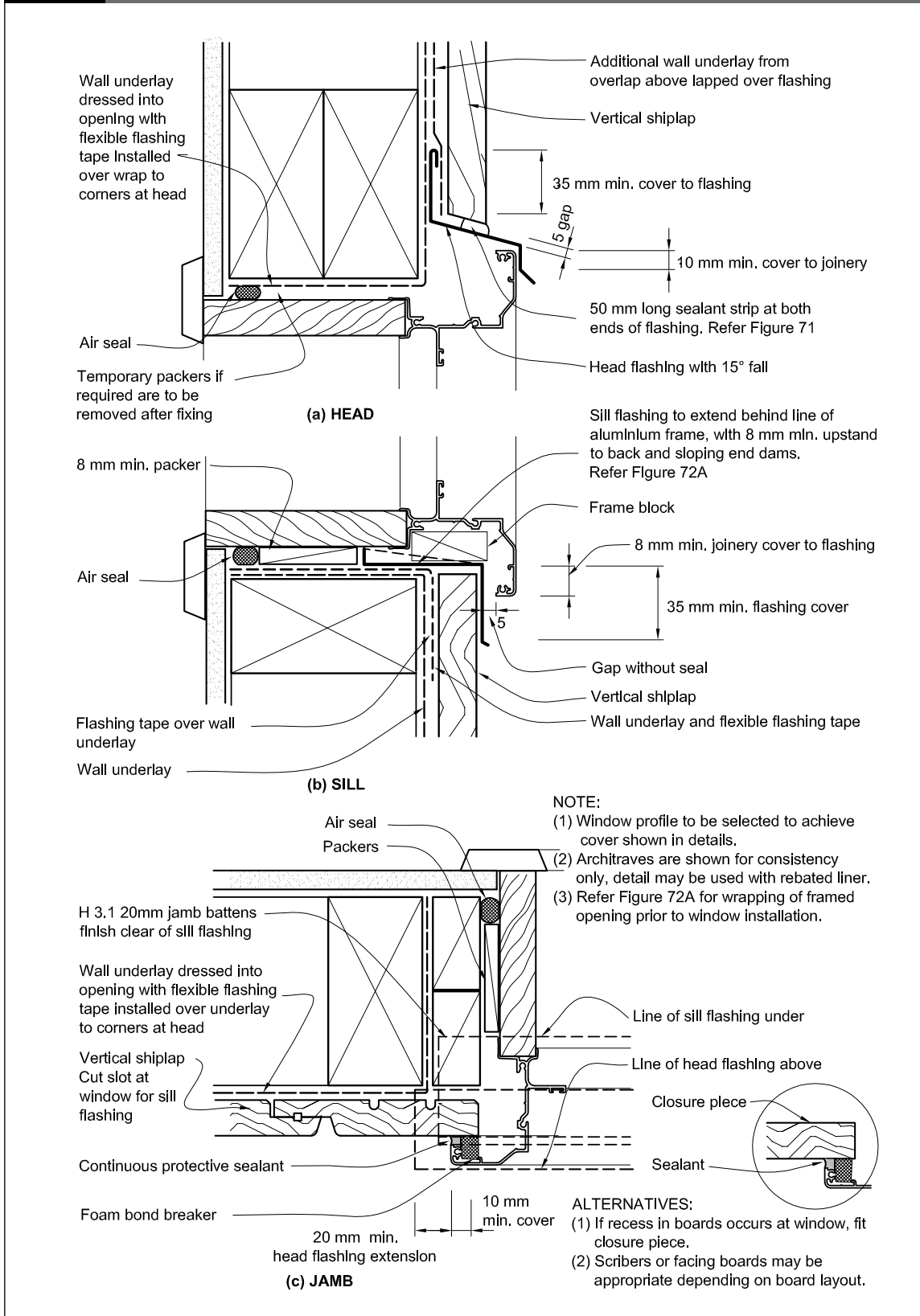

Amend 5
Aug 2011

Amend 2
Jul 2005

Figure 84: Windows and doors for direct fixed board and batten weatherboards
Paragraph 9.4.6

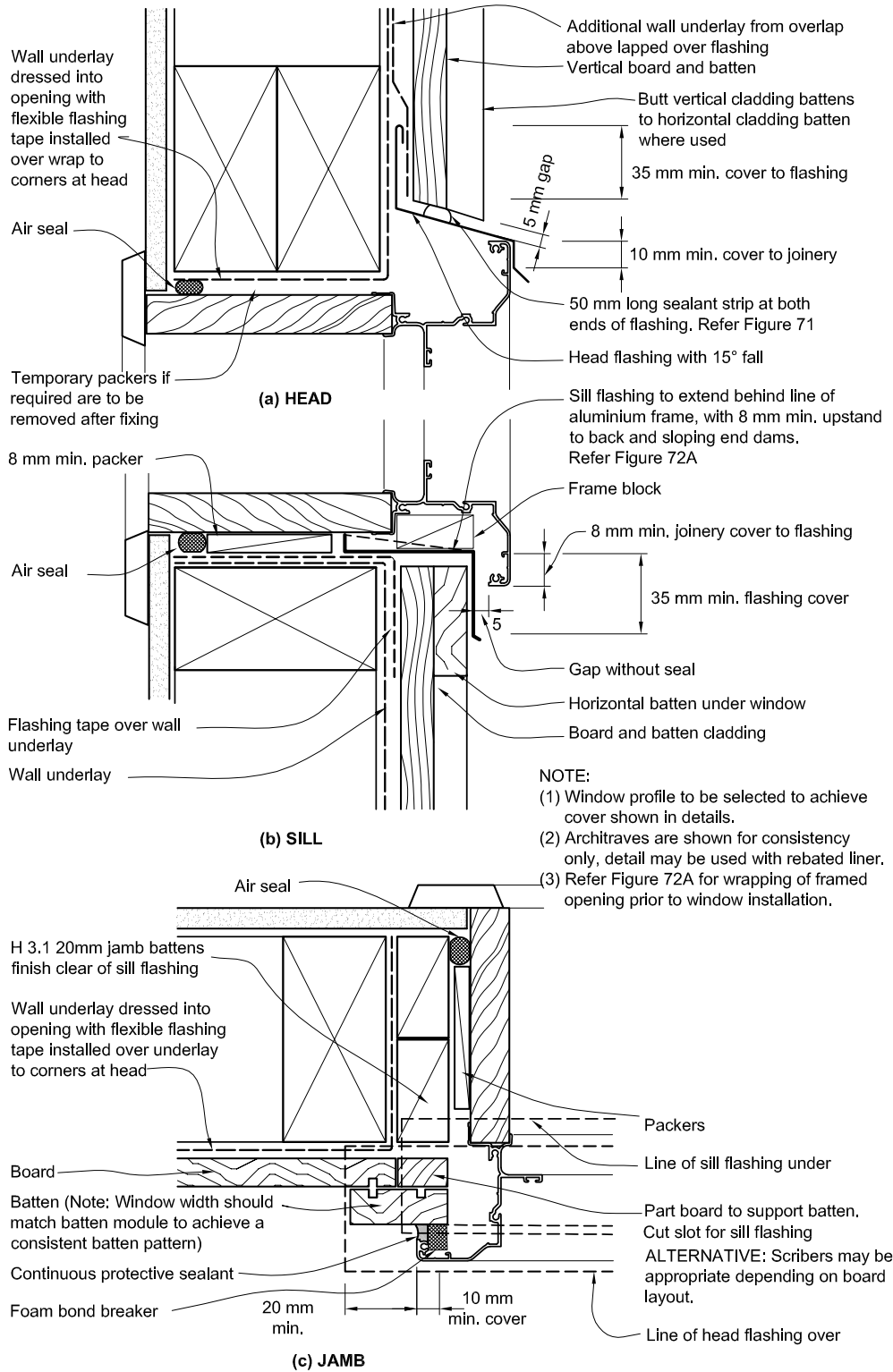

Amend 5
Aug 2011

Amend 2
Jul 2005

Figure 85: Windows and doors for bevel-back weatherboards on cavity
Paragraph 9.4.7

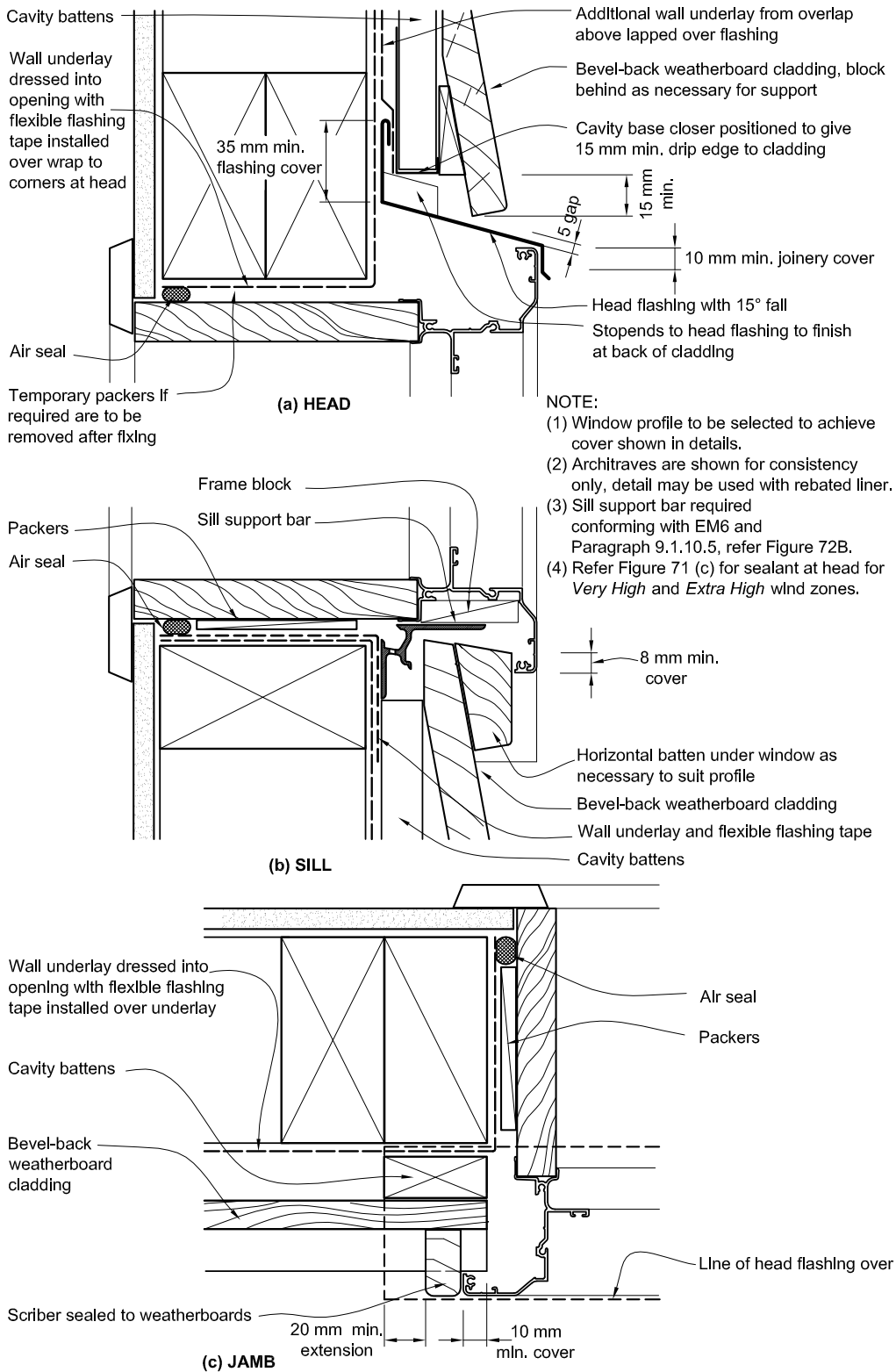

- NOTE:**
- (1) Window profile to be selected to achieve cover shown in details.
 - (2) Architraves are shown for consistency only, detail may be used with rebated liner.
 - (3) Sill support bar required conforming with EM6 and Paragraph 9.1.10.5, refer Figure 72B.
 - (4) Refer Figure 71 (c) for sealant at head for Very High and Extra High wind zones.

Amend 5
Aug 2011

Amend 2
Jul 2005

Figure 86: Windows and doors for rusticated weatherboards on cavity
Paragraph 9.4.7

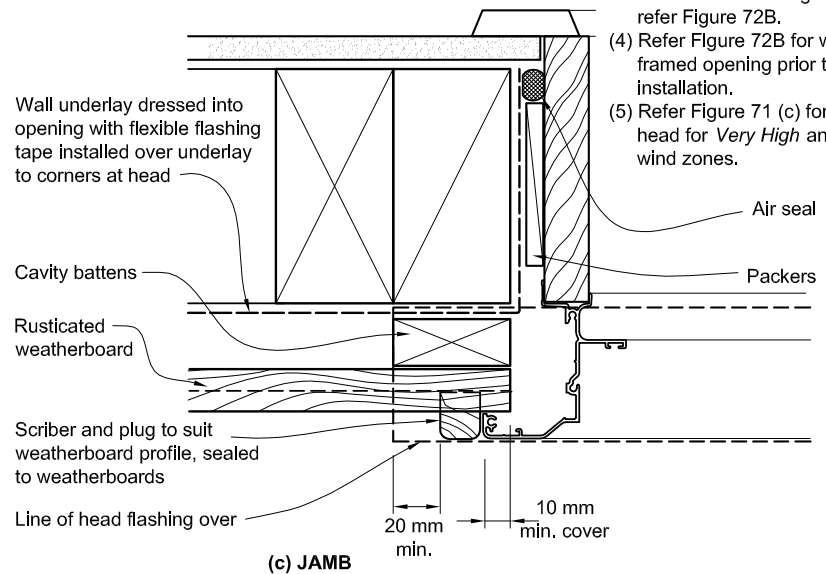
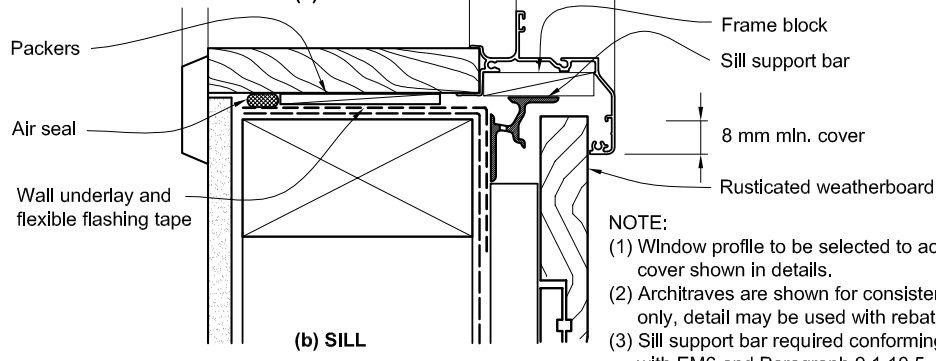
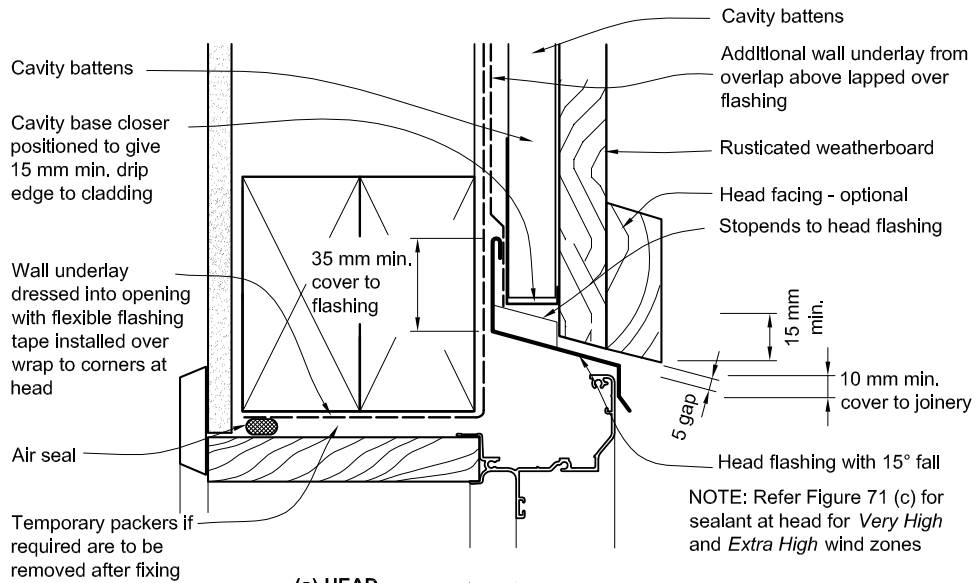

Amend 5
Aug 2011

Amend 2
Jul 2005

9.4.8 Parapets and enclosed balustrades

Parapets shall be in accordance with Paragraph 6.0.

Enclosed balustrades shall be in accordance with Paragraph 7.4.

9.4.9 Finishes

Where a protective finish is required by NZS 3602, all timber surfaces, including end grain and laps, shall be sealed by priming.

Two coats of exterior grade paint shall be applied, after priming, to all exposed surfaces. Paint systems shall comply with any of Parts 7, 8, 9 or 10 of AS 3730.

COMMENT:

The minimum *durability* period for protective coatings is 5 years. Improvement in *durability* and stability of weatherboards can be achieved by priming all surfaces including backs of boards.

Manufacturers of coatings which have a proven performance in use may be able to show compliance with NZBC B2 Durability as detailed in B2/VM1 as an alternative to compliance with AS 3730.

With tangentially-sawn weatherboards, particularly painted or stained in dark colours, cupping is possible. Providing additional fixings may help restrain the board, but will usually result in splitting of the boards.

Amend 5
Aug 2011

9.5 Fibre Cement Weatherboards

Amend 5
Aug 2011

Fibre cement weatherboard *claddings* shall be either *direct fixed* to *framing* over a *wall underlay*, or fixed over a *drained cavity* as described in Paragraph 9.1.8.

Based on the *risk score* for an *external wall*, calculated as per Paragraph 3.1, the fibre cement weatherboard *cladding* may require the inclusion of a *drained cavity*.

9.5.1 Limitations

This Acceptable Solution is limited to flat fibre cement weatherboards, with a minimum thickness of 7.5 mm.

9.5.2 Material performance

Fibre cement weatherboards shall comply with AS/NZS 2908: Part 2.

9.5.3 Installation

Amend 5
Aug 2011

A *wall underlay*, as specified in Table 23 and Paragraphs 9.1.5–9.1.7, shall be installed behind fibre cement weatherboard *claddings*.

COMMENT:

Refer to Paragraph 1.5 for qualification of installers.

Amend 5
Aug 2011

9.5.3.1 Fixings

Fibre cement weatherboards shall be fixed through the *wall underlay* to the *framing* at maximum 600 mm centres as per Table 24.

Amend 5
Aug 2011

9.5.3.2 Laps and joints

Horizontal laps shall be a minimum of 30 mm.

Joints shall be:

- a) Positioned between *studs*,
- b) Staggered at a minimum of 600 mm from joints in the adjacent boards, and
- c) Weatherproofed by:
 - i) uPVC H jointers as shown in Figure 87, or
 - ii) hidden soakers as shown in Figure 87, with sealant used between ends of boards complying with:
 - a. Type F, Class 20LM or 25LM of ISO 11600, or
 - b. low modulus Type II Class A of Federal Specification TT-S-00230C.

Figure 87: Joints in fibre cement weatherboards
Paragraph 9.5.3.2

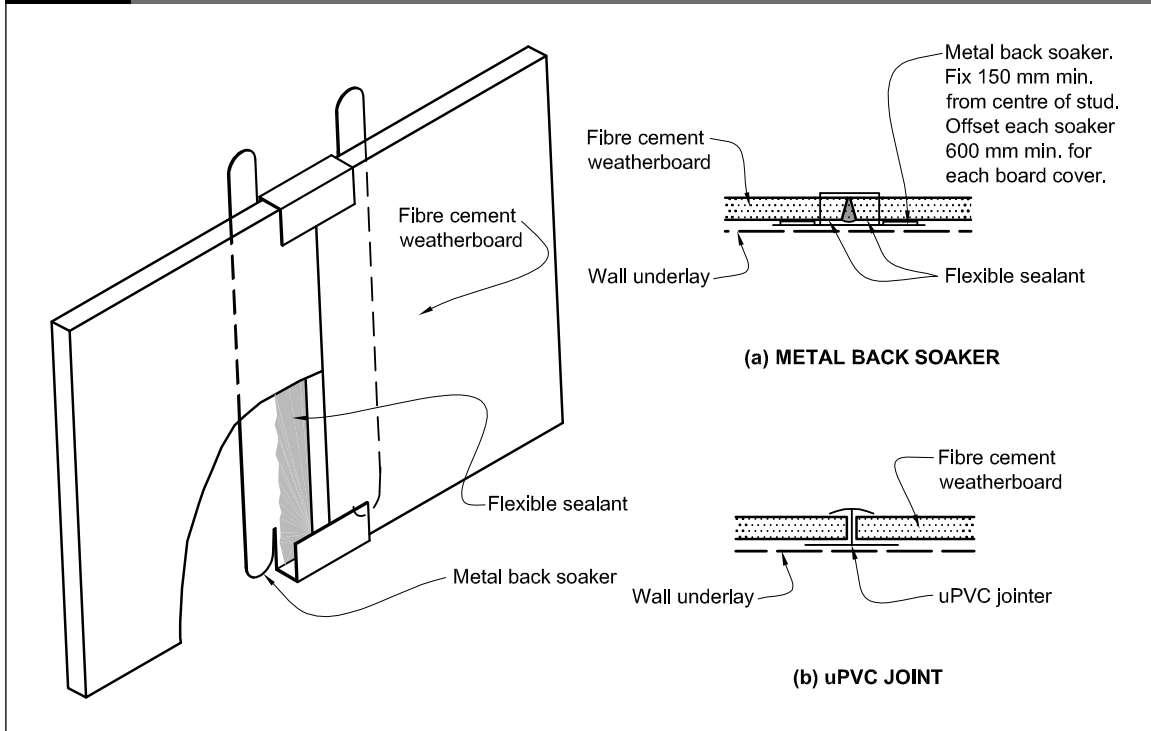

Amend 5
Aug 2011

Amend 2
Jul 2005

9.5.3.3 External corners

External corners shall be weatherproofed as shown in Figure 88 by:

- a) The use of corrosion-resistant soakers complying with Paragraph 4.2.2 to Paragraph 4.3.6, or
- b) Facings with weathergrooves.

Amend 5
 Aug 2011

9.5.3.4 Internal corners

Internal corners shall be weatherproofed by metal corner *flashings* as shown in Figure 89.

Amend 5
 Aug 2011

9.5.4 Windows and doors

Windows and doors shall be installed in accordance with Paragraph 9.1.10.

Amend 5
 Aug 2011

9.5.4.1 Windows and doors – direct fixed

For *direct fixed* fibre cement weatherboards, windows and doors shall be detailed as shown in Figure 90 and Figure 17D.

Amend 5
 Aug 2011

9.5.4.2 Windows – on cavity

For fibre cement weatherboards fixed over a *drained cavity*, windows and doors shall be detailed as shown in Figure 91 and Figure 17C.

Amend 5
 Aug 2011

9.5.5 Parapets and enclosed balustrades

Parapets shall be in accordance with Paragraph 6.0.

Enclosed balustrades shall be in accordance with Paragraph 7.4.

9.5.6 Protective coating

The exposed faces, including top edges at sills and all bottom edges, of horizontal fibre cement weatherboards shall be finished with a minimum of a 2-coat latex exterior paint system complying with any of Parts 7, 8, 9 or 10 of AS 3730.

Amend 2
 Jul 2005

Figure 88: External corners in fibre cement weatherboards
 Paragraph 9.5.3.3

NOTE: (1) Boxed external corner details for cavity walls are similar.
 (2) Soaker corners for cavity walls are similar to Figure 77.

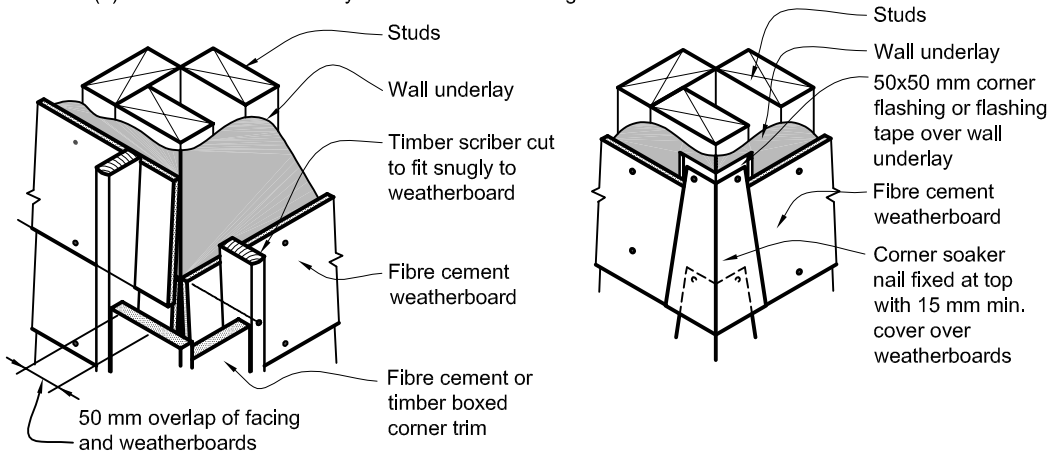

Amend 2
 Jul 2005

Amend 2
 Jul 2005

Amend 5
 Aug 2011

Figure 89: Aluminium corners in fibre cement weatherboards
Paragraph 9.5.3.4

NOTE: Corner details for cavity walls are similar.

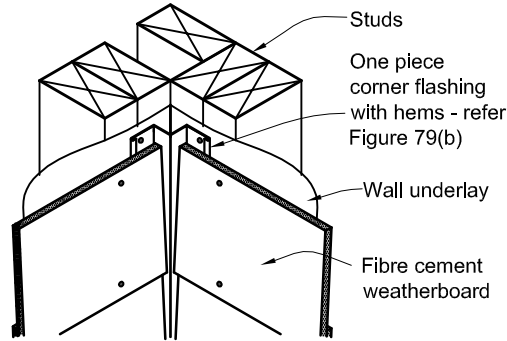

Amend 5
Aug 2011

Figure 90: Windows and doors in fibre cement direct fixed weatherboards
Paragraph 9.5.4.1

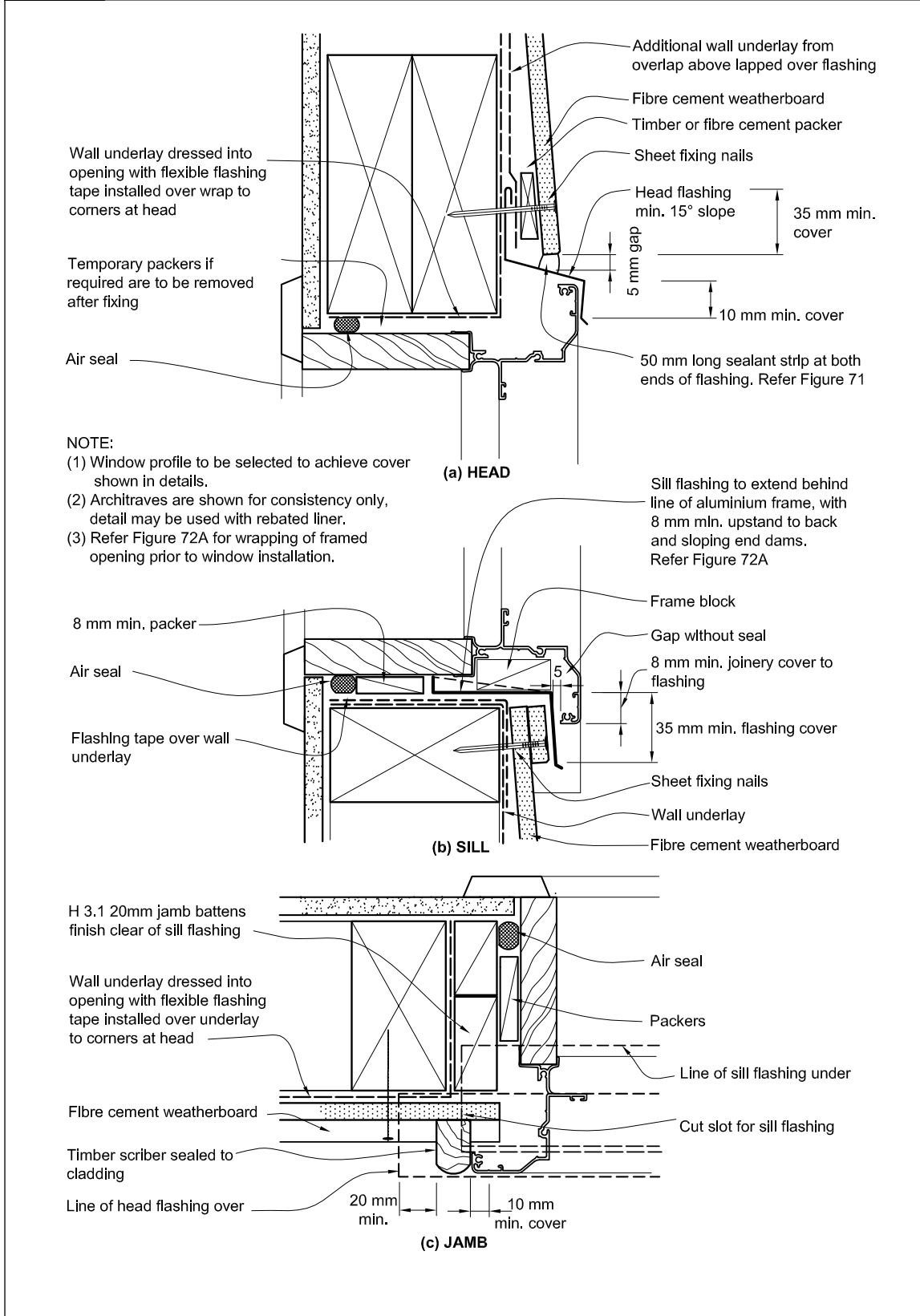

Amend 2
Jul 2005

Amend 5
Aug 2011

Figure 91: Windows and doors in fibre cement weatherboards on cavity
Paragraph 9.5.4.2

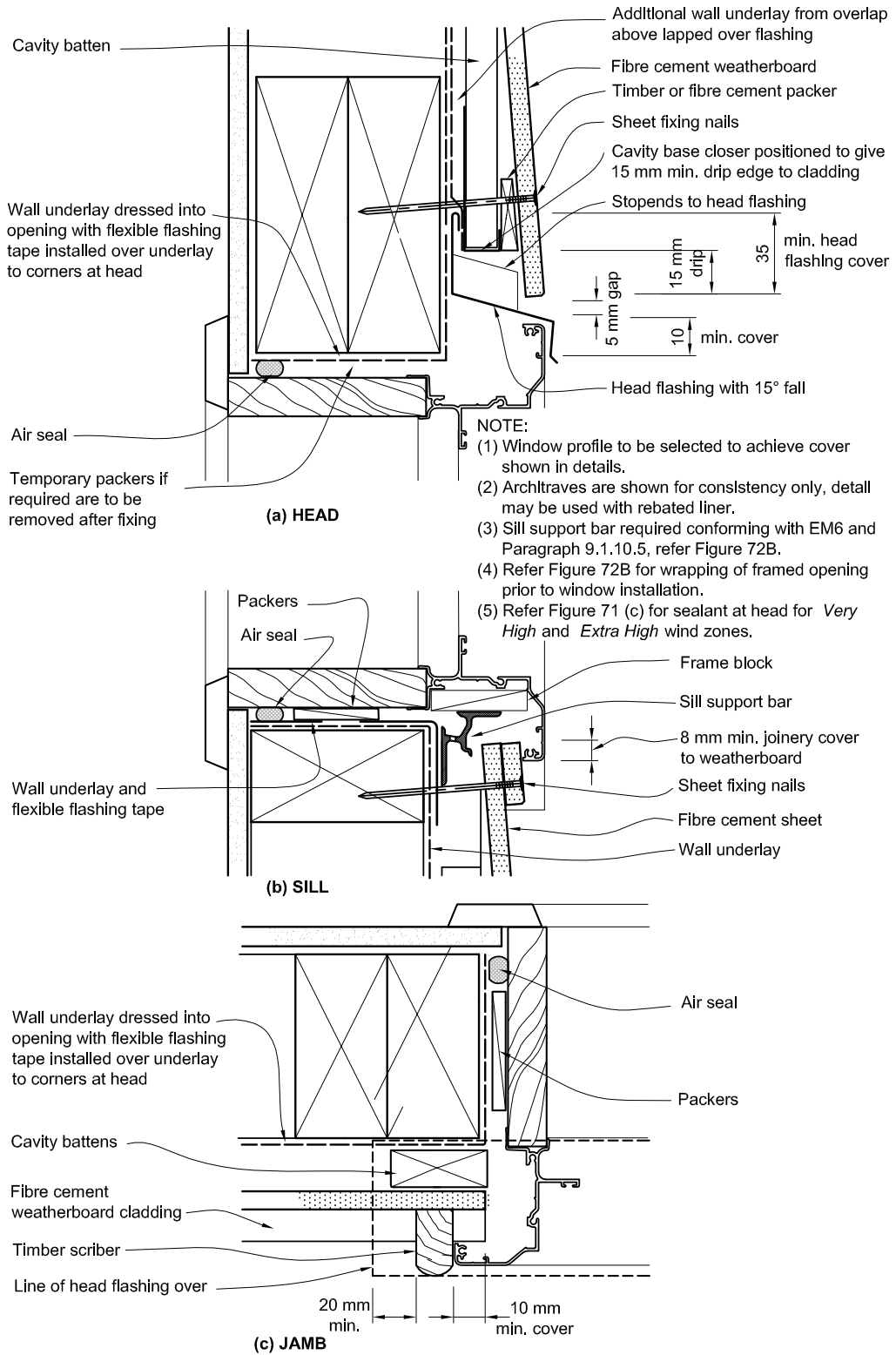

Amend 5
Aug 2011

Amend 2
Jul 2005

Amend 2
Jul 2005

9.6 Profiled Metal Wall Cladding

Horizontal profiled metal wall *cladding* shall be fixed over a *drained cavity* as described in Paragraph 9.1.8.

Vertical profiled metal wall *cladding* shall be *direct fixed* to *framing* over a *roof underlay*.

Refer to Table 3: Suitable *wall claddings*.

9.6.1 Limitations

This Acceptable Solution is limited to corrugated or *trapezoidal* metal wall *cladding* with the profiles, as shown in Figure 38, and applied as outlined in Table 3.

Amend 2
Jul 2005
Amend 5
Aug 2011

9.6.2 General

COMMENT:

Refer to Paragraph 1.5 for qualification of installers.

Amends
2 and 5

9.6.3 Materials

9.6.3.1 Choice of metal

The metal *cladding* shall be selected according to the exposure conditions in Table 20 as defined in:

- a) NZS 3604, or
- b) AS/NZS 2728.

Amend 5
Aug 2011

Amend 5
Aug 2011

COMMENT:

The exposure zone in which a *building* is located can affect the *durability* of *flashings*.

Exposure zones are defined in NZS 3604, based on the likely exposure to wind-driven sea-salt. Corrosion due to geothermal or corrosive industrial atmospheres, as defined in NZS 3604, requires *specific design*.

Exposure zones are based on AS/NZS 2728. AS/NZS 2728 lists atmospheric classes derived from ISO 9223 for Australia and New Zealand.

Amend 5
Aug 2011

9.6.3.2 Steel

Materials for the manufacture of profiled steel *cladding* shall:

- a) Have a *BMT* of 0.4 mm minimum,
- b) Be grade G550, or G300 for curved and crimped cladding
- c) Be selected for corrosion protection according to the intended exposure zone as shown in Table 20.

Amend 2
Jul 2005

Amend 2
Jul 2005

Amend 2
Jul 2005

Amend 5
Aug 2011

9.6.3.3 Aluminium

Aluminium for the manufacture of profiled aluminium wall *cladding* shall comply with AS/NZS 1734, and be:

- a) A *base metal thickness (BMT)* of a minimum of 0.7 mm,
- b) Minimum 5000 series.

Amend 2
Jul 2005

For pre-painted aluminium, a factory-applied finish complying with AS/NZS 2728 shall be applied.

9.6.4 Maintenance

Refer to Paragraph 2.5.

Amend 5
Aug 2011

Amend 5
Aug 2011**9.6.5 Profiles**

Profiles covered in this Acceptable Solution are:

- a) Corrugated – curved with a minimum crest height of 16.5 mm minimum, and
- b) *Trapezoidal* – symmetrical and asymmetrical with a minimum crest height of 19 mm.

For details of these profiles, refer to Figure 38.

9.6.6 Fixing

The *cladding* shall be screw-fixed through the troughs and battens, where applicable, into the *framing*. Fixings shall:

- a) Be minimum 12-gauge hexagonal head, self-drilling wood screws,
- b) Penetrate the *framing* by a minimum of 30 mm,
- c) Be minimum Class 4 to AS 3566: Part 2, selected from Table 20,
- e) Include neoprene (having a carbon black content of 15% or less by weight) or *EPDM* sealing washers as shown in Figure 39, and
- f) Be used on the *cladding* at side laps and every second trough or, for *trapezoidal* where the rib centres exceed 150 mm, at side laps and every trough:
 - i) to *framing*, and
 - ii) at all external and internal corners.

9.6.7 Flashings

Flashings used with metal *wall cladding* shall be in accordance with Paragraph 4.0, and with the following requirements:

- a) *Hooks* and *hems* shall be as shown in Figure 5,
- b) Have joints formed with laps and sealant as shown in Figure 6,

c) Where shown, sealant shall be neutral cure, complying with:

- i) Type F, Class 20LM or 25LM of ISO 11600, or
- ii) low modulus Type II Class A of Federal Specification TT-S-00230C,

d) *Under-flashings* shall be fixed to *framing* at 600 mm maximum centres.

e) *Flashings* shall be fixed together at junctions at 50 mm maximum centres or to *cladding* at 900 mm centres with:

- i) for galvanized steel, 4 mm diameter monel metal or stainless steel rivets, where compatible as per Table 21, or
- ii) for aluminium-zinc coated steel, 4 mm diameter aluminium rivets, or
- iii) for aluminium, 4 mm diameter aluminium rivets.

9.6.8 Vertical profile – direct fixed**9.6.8.1 Installation**

For *direct fixed* vertical profile, the *wall underlay* shall be in accordance with the properties listed for *roof underlay* in Table 23.

For copper-based treated *framing* or *underlay* refer to Paragraph 9.6.9.2.

COMMENT:

In *direct fixed* metal *cladding*, the *wall underlay* will be in contact with the back of the vertical profiled metal *cladding*. *Underlay* is needed to separate treated timber from the back of the metal to minimise the risk of *electrolytic corrosion*.

Amend 2
Jul 2005Amend 2
Jul 2005Amend 2
Jul 2005Amend 5
Aug 2011Amend 5
Aug 2011Amend 5
Aug 2011

9.6.8.2 Barges

Barge flashings shall be as shown in Figure 92.

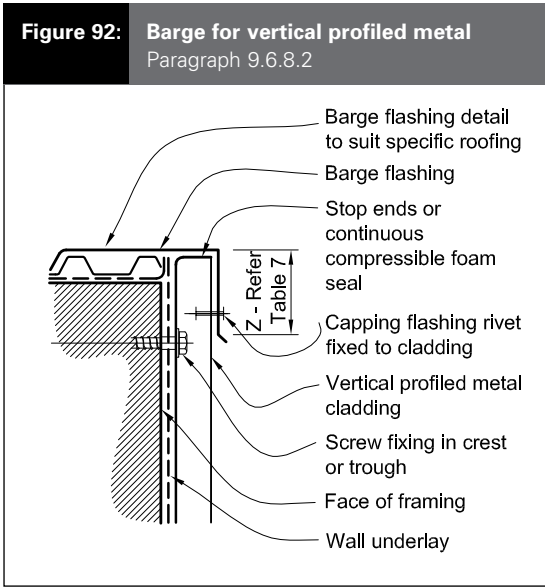

Amend 2
Jul 2005

Amend 2
Jul 2005

Amend 5
Aug 2011

9.6.8.4 Corners

Direct fixed vertical profiled metal wall cladding shall be over-flashed at external and internal corners as shown in Figure 94. The cover of the flashings shall:

- a) Be dimensioned to suit the metal wall cladding profile,
- b) Cover at least two crests for corrugated and single crests for other profiles, and
- c) Terminate as shown in Figure 93.

Amend 5
Aug 2011

Amend 2
Jul 2005

9.6.8.3 Bottom of cladding

The bottom edge of the cladding shall overlap the foundation wall as described in Paragraph 9.1.3 and as shown in Figure 93.

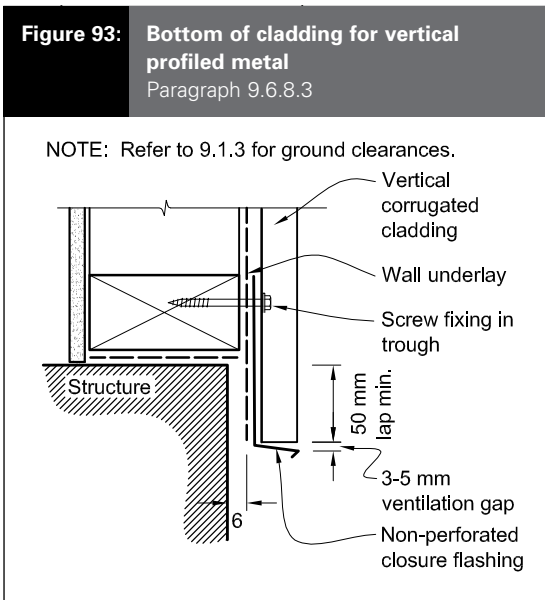

Amend 2
Jul 2005

Amend 5
Aug 2011

Figure 94: Corners for vertical profiled metal
Paragraph 9.6.8.4

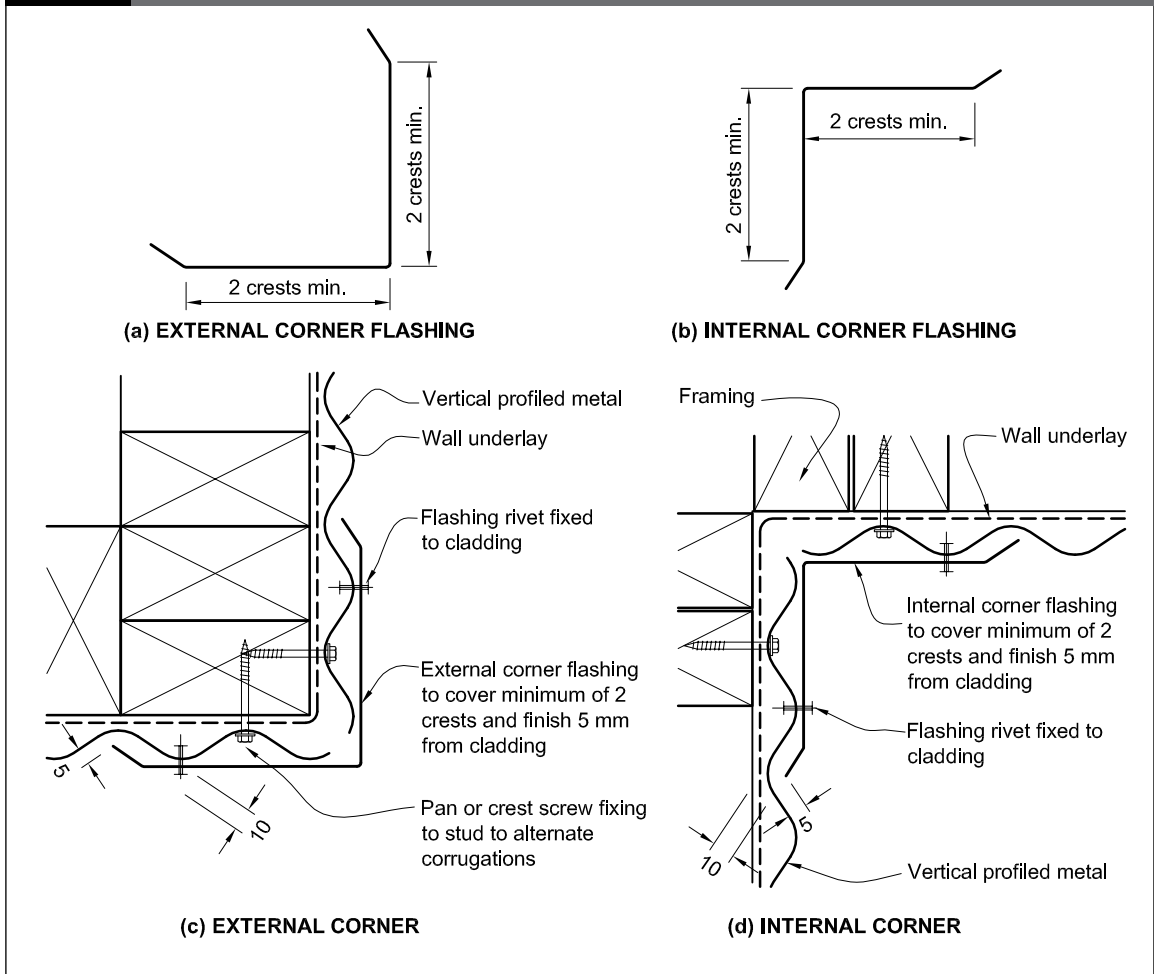

Amend 5
Aug 2011

9.6.8.5 Vertical profile: penetrations

Pipe penetrations shall be as per Figure 53.

The heads of larger penetrations shall be flashed in similar fashion to Figure 69, with head flashings adjusted to suit the profile and other flashings as per window and door details in relevant paragraphs.

Amend 5
Aug 2011

9.6.8.6 Vertical profile: windows and doors

Windows and doors in vertical profiled metal claddings shall be flashed as shown in Figure 95 and Figure 100.

Amend 5
Aug 2011

Figure 95: Windows and doors for vertical profiled metal
Paragraph 9.6.8.6

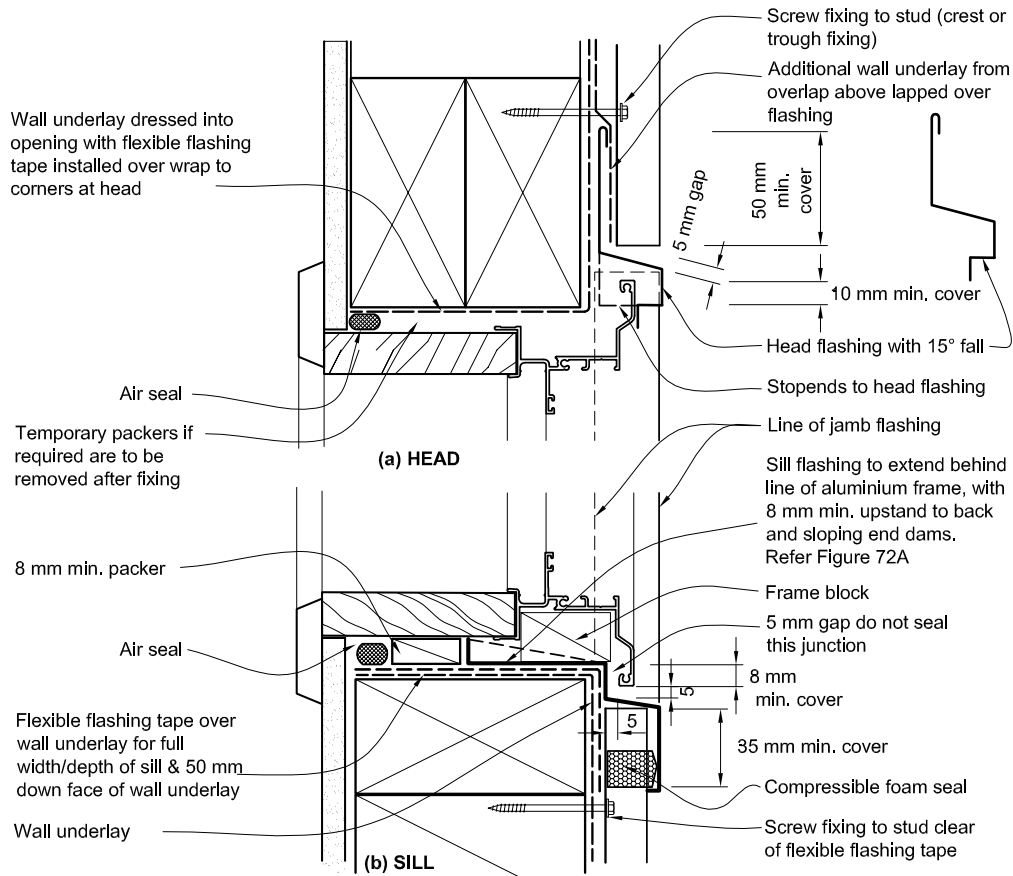

NOTE:

- (1) Window profile to be selected to achieve cover shown in details.
- (2) Architraves are shown for consistency only, detail may be used with rebated liner.
- (3) Refer Figure 72A for wrapping of framed opening prior to window installation.
- (4) Refer Figure 100 for sketch of flashings.
- (5) Refer Figure 71 (c) for sealant at head for *Very High* and *Extra High* wind zones.

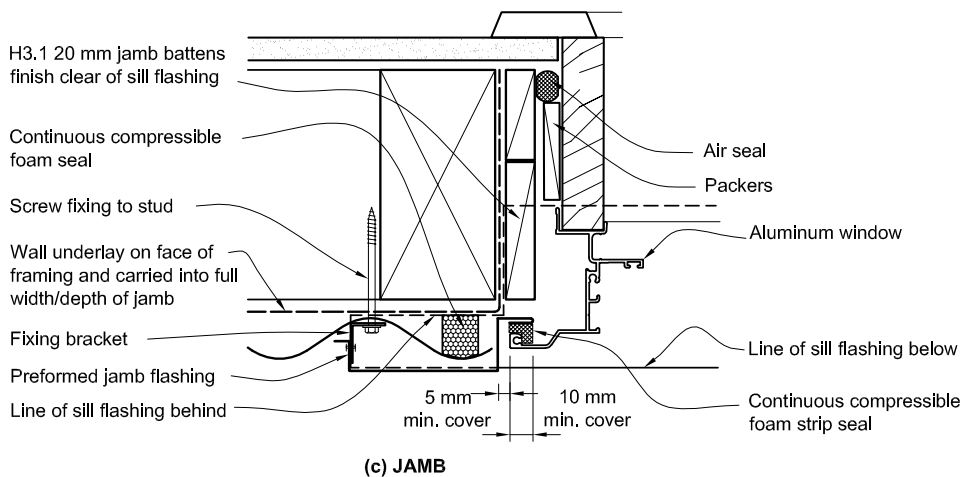

Amend 5
Aug 2011

Amend 2
Jul 2005

Amend 5
Aug 2011

9.6.9 Horizontal profiled metal on cavity

9.6.9.1 Installation

A *wall underlay*, as specified in Table 23 and Paragraphs 9.1.5–9.1.7, shall be installed over the outside face of the *framing*.

9.6.9.2 Cavity battens

If the *cavity batten* contains copper (e.g. CCA, copper azole or ACQ), appropriate separation between the back of the *cladding* and the *cavity batten* shall be provided.

Examples of suitable separation are:

- a) An additional layer of paper-based *underlay*, complying with Table 23, over *cavity battens*,
- b) Strips of paper-based *underlay* complying with Table 23 on the face of *cavity battens*,
- c) Pre-priming *cavity battens*.

Amends
2 and 5

Amend 2
Jul 2005

9.6.9.3 Corners

Corners shall be weatherproofed by using the *flashings* and details shown in Figure 96.

Horizontal profiled metal wall *cladding* shall be under-flashed using *butt flashings* which shall:

- a) Be formed in one shaped piece,
- b) Allow metal *cladding* to butt, with a separation of 5 mm, against sides of the exposed *flashing* corner, and
- c) Use profiled compressible foam to seal between the *flashing* underlap and underside of *cladding*.

Amend 5
Aug 2011

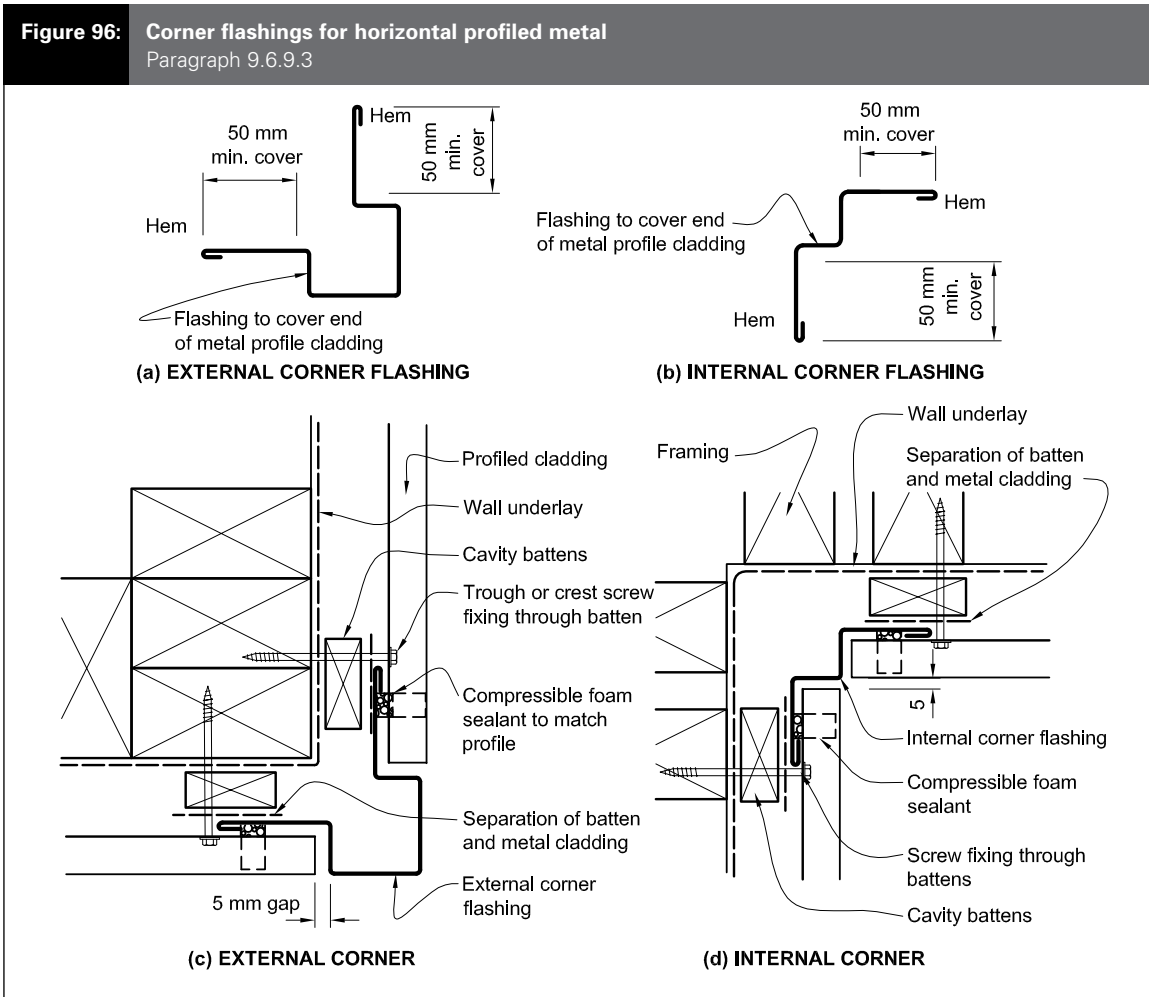

Amend 2
Jul 2005

Amend 5
Aug 2011

9.6.9.4 Barges

Barge flashings shall be as shown in Figure 97.

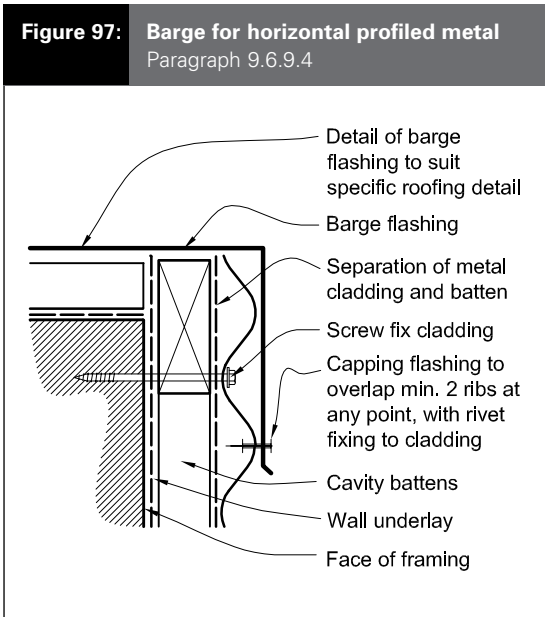

Amend 2
 Jul 2005

Amend 2
 Jul 2005

Amend 5
 Aug 2011

9.6.9.5 Bottom of cladding

The bottom edge of the *cladding* shall overlap the foundation *wall* as described in Paragraph 9.1.3 and as shown in Figure 98.

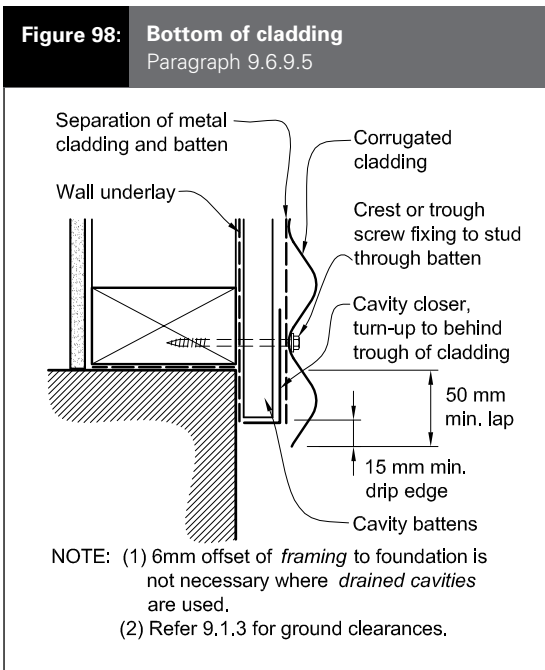

Amend 2
 Jul 2005

Amend 5
 Aug 2011

9.6.9.6 Horizontal profile: penetrations

All services penetrations through *claddings* shall be flashed and sealed. Pipe penetrations are shown in Figure 53.

The heads of larger penetrations shall be flashed in a similar fashion to Figure 69.

9.6.9.7 Horizontal profile: windows and doors

Windows and doors shall be installed in accordance with Paragraph 9.1.10, and as shown in Figure 99 and Figure 100.

9.6.9.8 Parapets and balustrades

Refer to Figures 101 and 102 for horizontal and vertical profiled metal.

Parapets shall be in accordance with Paragraph 6.0.

Enclosed balustrades shall comply with Paragraph 7.4.

Amend 5
 Aug 2011

Amend 5
 Aug 2011

Amend 5
 Aug 2011

COMMENT:

Side fixings of *handrails* or other attachments to *enclosed balustrades* or *parapets* will require *specific design* to demonstrate *weathertightness*, together with specific structural design for *stanchion* fixings.

Amend 2
 Jul 2005

Figure 99: Windows and doors for horizontal profiled metal on cavity
Paragraph 9.6.9.7

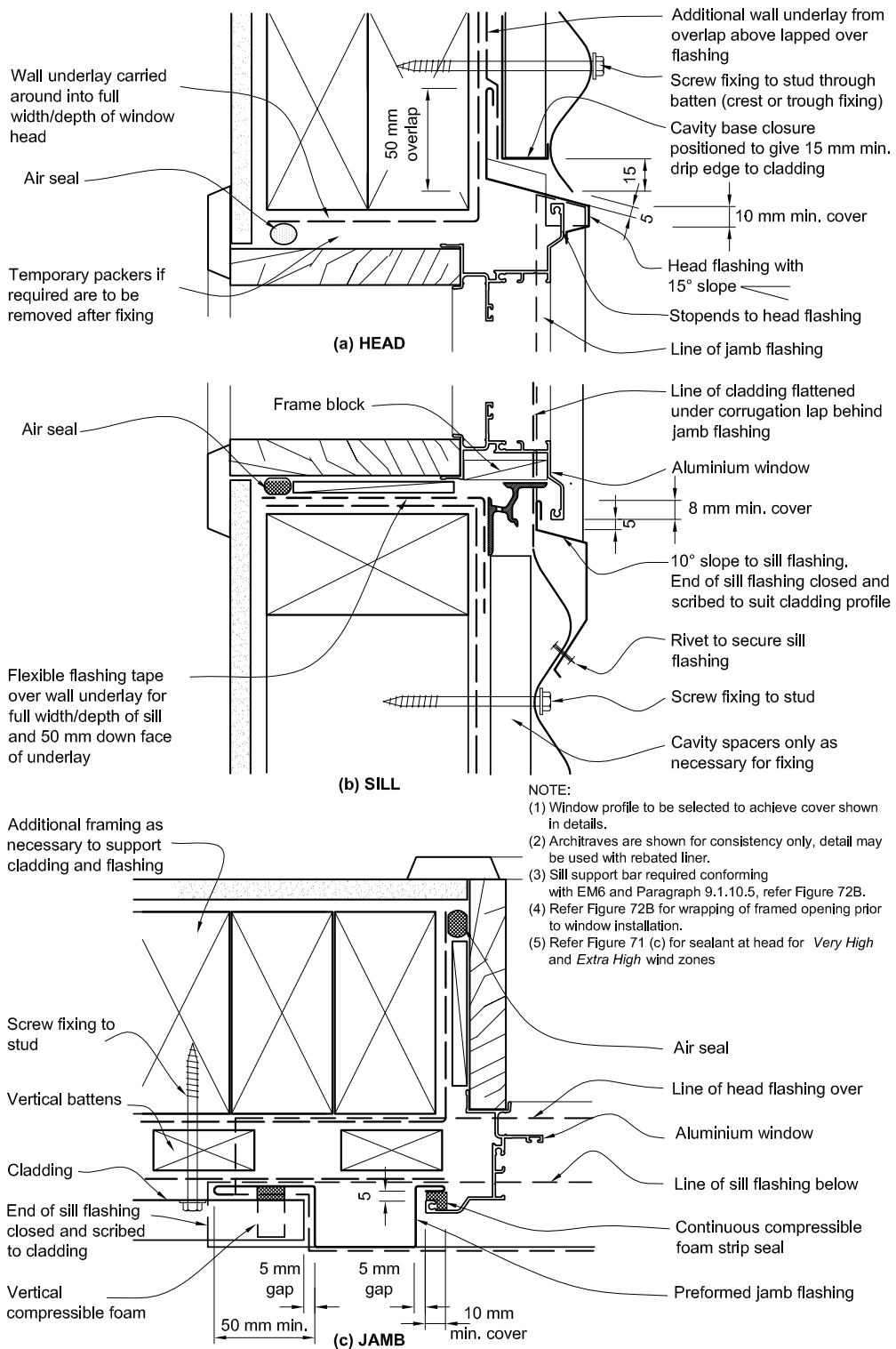

Amend 5
Aug 2011

Amend 2
Jul 2005

Figure 100: Window and door flashings for profiled metal
 Paragraphs 9.6.8.6 and 9.6.9.7, Figures 95 and 99

NOTE: (1) Detail (a) *Direct fixed vertical profile*: refer Figure 95 for window.
 (2) Detail (b) *Horizontal profile on cavity*: refer Figure 99 for window.
 (3) *Wall underlay* omitted for clarity.

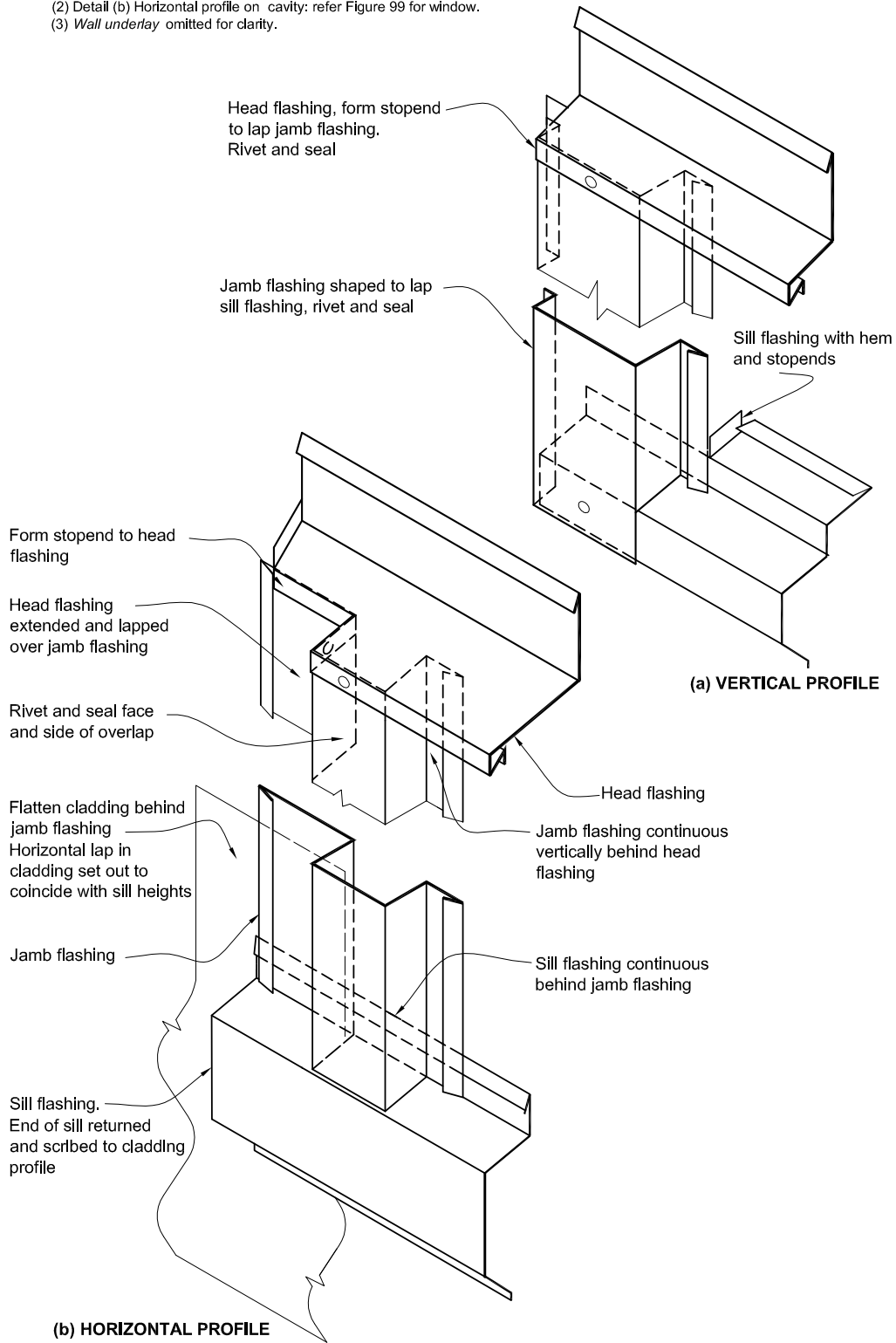

Amend 2
 Jul 2005

Amend 5
 Aug 2011

Figure 101: Balustrade and parapet for vertical profiled metal
Paragraph 9.6.9.8

Amend 2
Jul 2005

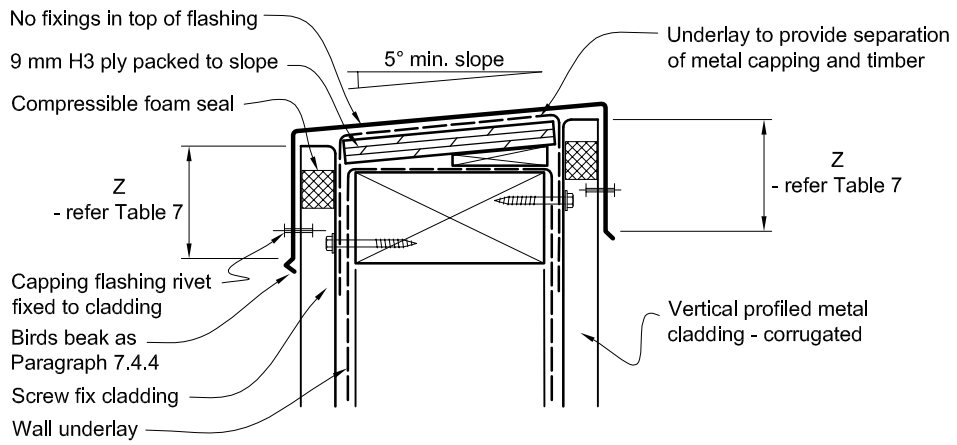

Amend 5
Aug 2011

Figure 102: Balustrade and parapet for horizontal profiled metal
Paragraph 9.6.9.8

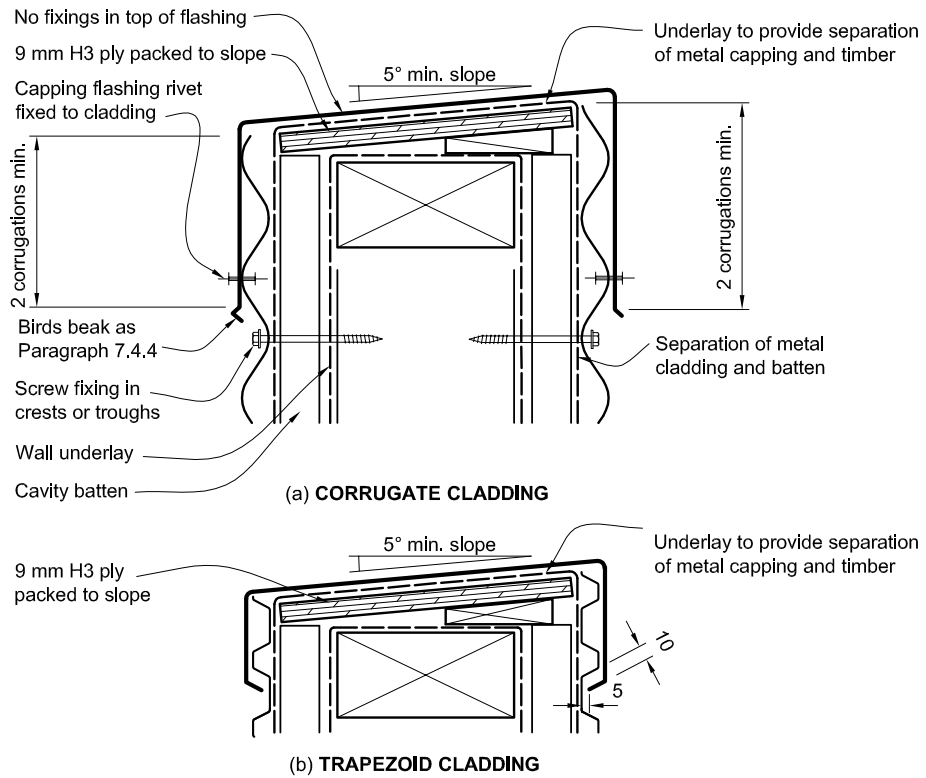

Amend 5
Aug 2011

Figure 103 deleted

9.7 Fibre Cement Sheet

Fibre cement sheet *claddings* shall be either *direct fixed* to *framing* over a *wall underlay* or fixed over a *drained cavity* based on the *risk score* for an *external wall*, calculated as per Paragraph 3.1 and Table 3.

Amend 5
Aug 2011**9.7.1 Limitations**

This Acceptable Solution is limited to the following types of fibre cement sheet *cladding systems*:

- a) *Flush-finished* systems over a drained cavity using sheets of 7.5 mm minimum thickness, with
 - i) fibre cement sheets manufactured with a rebated edge for this purpose,
 - ii) if necessary for part sheets, rebated on site using a purpose-made tool, and
 - iii) have all edges sealed,
 - iv) joints, comprising a bedding compound and reinforcing tape, that are finished in accordance with Paragraph 9.7.10.4, or
- b) Jointed systems in accordance with Paragraph 9.7.3 using sheets of 6 mm minimum thickness with:
 - i) purpose-made jointers,
 - ii) timber battens over joints.

Amend 5
Aug 2011Amend 2
Jul 2005Amend 2
Jul 2005Amend 5
Aug 2011**9.7.2 Material and installation – both systems**

Fibre cement shall comply with AS/NZS 2908: Part 2.

9.7.2.1 Installation

Install sheets with:

- a) Paint seals to all sheet edges and cut edges, including 100 mm across back face from each edge
- b) A *wall underlay*, as specified in Table 23 and Paragraphs 9.1.5–9.1.7, installed behind fibre cement sheet *claddings*
- c) Fixings as required in Table 24, installed through the *wall underlay* into the *wall framing*
- d) All sheet joints located over solid *framing*.

COMMENT:

Refer to Paragraph 1.5 for qualification of installers.

Edge sealing can be improved by application of a second seal coating.

It is recommended that the applicator of the *flush-finished* jointing and coating be trained and approved by the supplier of the jointing and finish system.

9.7.3 Jointed systems

Jointed systems shall have:

- a) Vertical joints with either:
 - i) uPVC jointers – Figure 104A
 - ii) timber battens – Figure 105A.
- b) Internal corners:
 - i) uPVC jointers – Figure 104B
 - ii) timber battens – Figure 104B.
- c) External corners
 - i) timber battens – Figure 105.
- d) Horizontal joints with either:
 - i) 'Z' *flashings*, to Figure 107 for Direct fixed claddings
 - ii) 'Z' *flashings* to Figure 108 for cavity fixed systems.

Flashings shall be either, uPVC, aluminium, stainless steel, or copper to Paragraph 4.3.

Timber battens shall comply with NZS 3602.

Amend 5
Aug 2011

Figure 104A: Vertical uPVC joints for fibre cement sheet
Paragraph 9.7.3

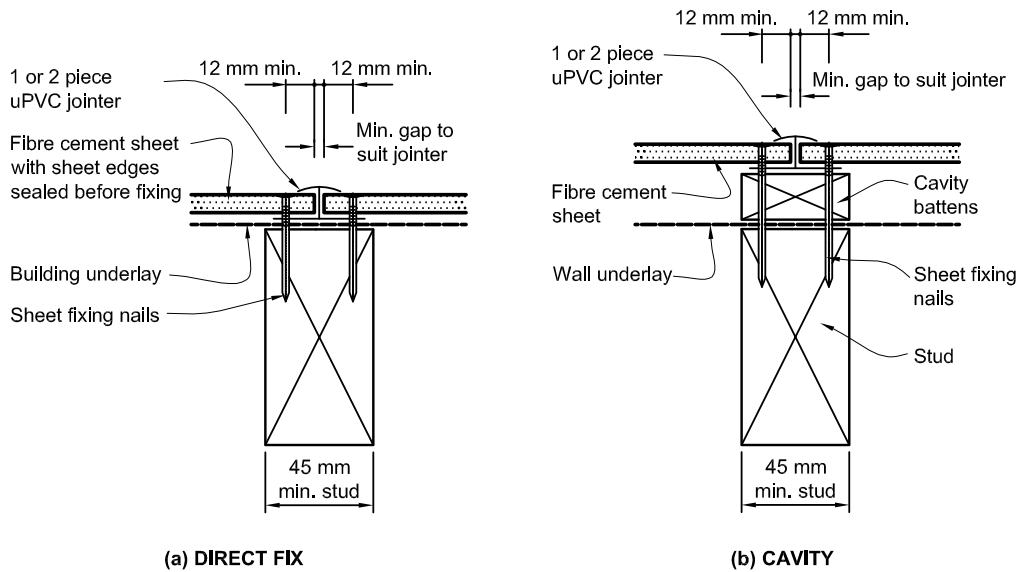

Amend 5
Aug 2011

Figure 104B: Internal corners for fibre cement sheet
Paragraph 9.7.3

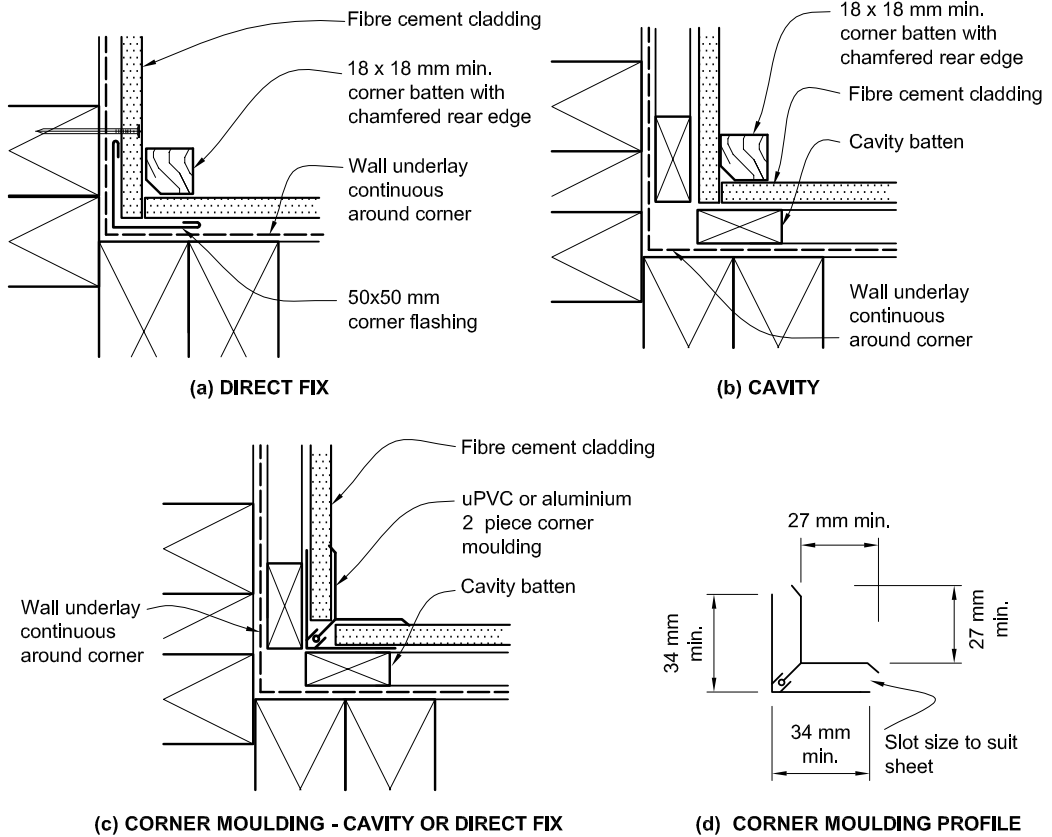

Amend 5
Aug 2011

Figure 105: Vertical timber batten joints for fibre cement sheet
Paragraph 9.7.3

NOTE:

- (1) Fibre cement sheet to be sealed including all edges before fixing batten.
- (2) Corner battens shall be sized to provide 50 mm minimum cover over cladding.

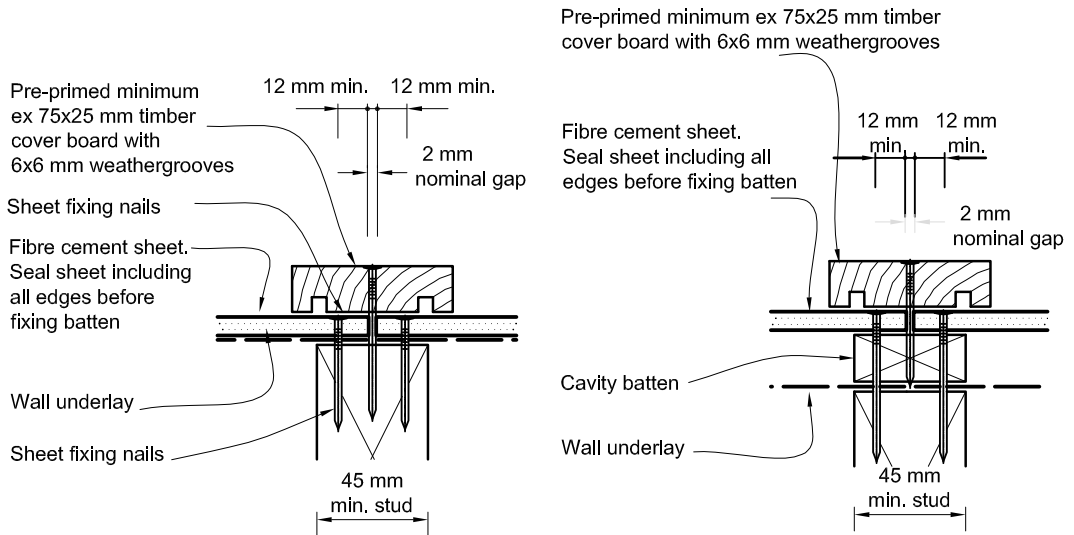

(a) SHEET JUNCTION DIRECT FIX

(b) SHEET JUNCTION CAVITY

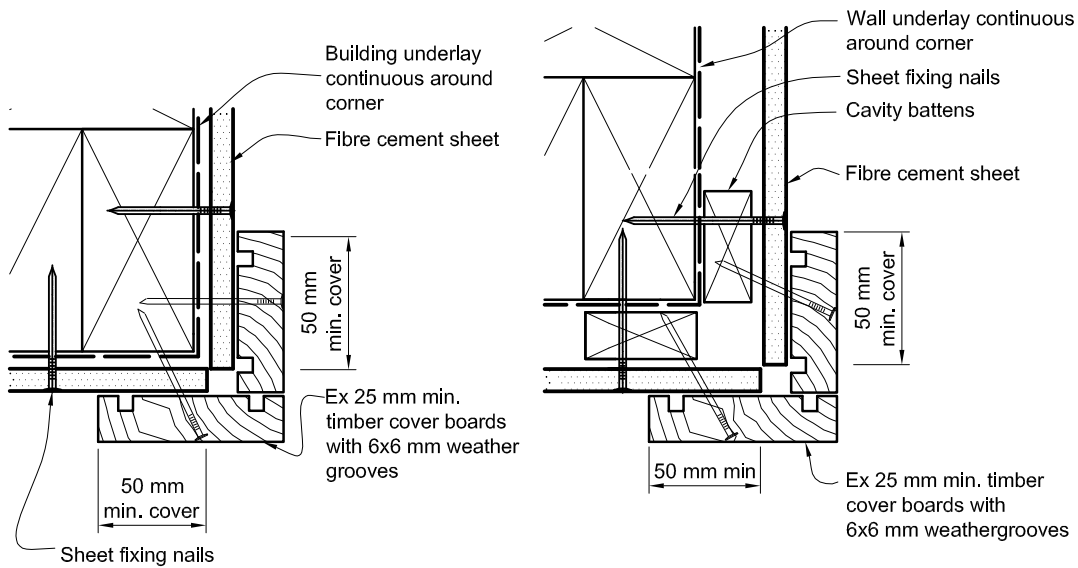

(c) EXTERNAL CORNER DIRECT FIX

(d) EXTERNAL CORNER CAVITY

Amend 5
Aug 2011

Figure 106 deleted

Figure 107: Horizontal joints for direct fixed fibre cement
Paragraph 9.7.3

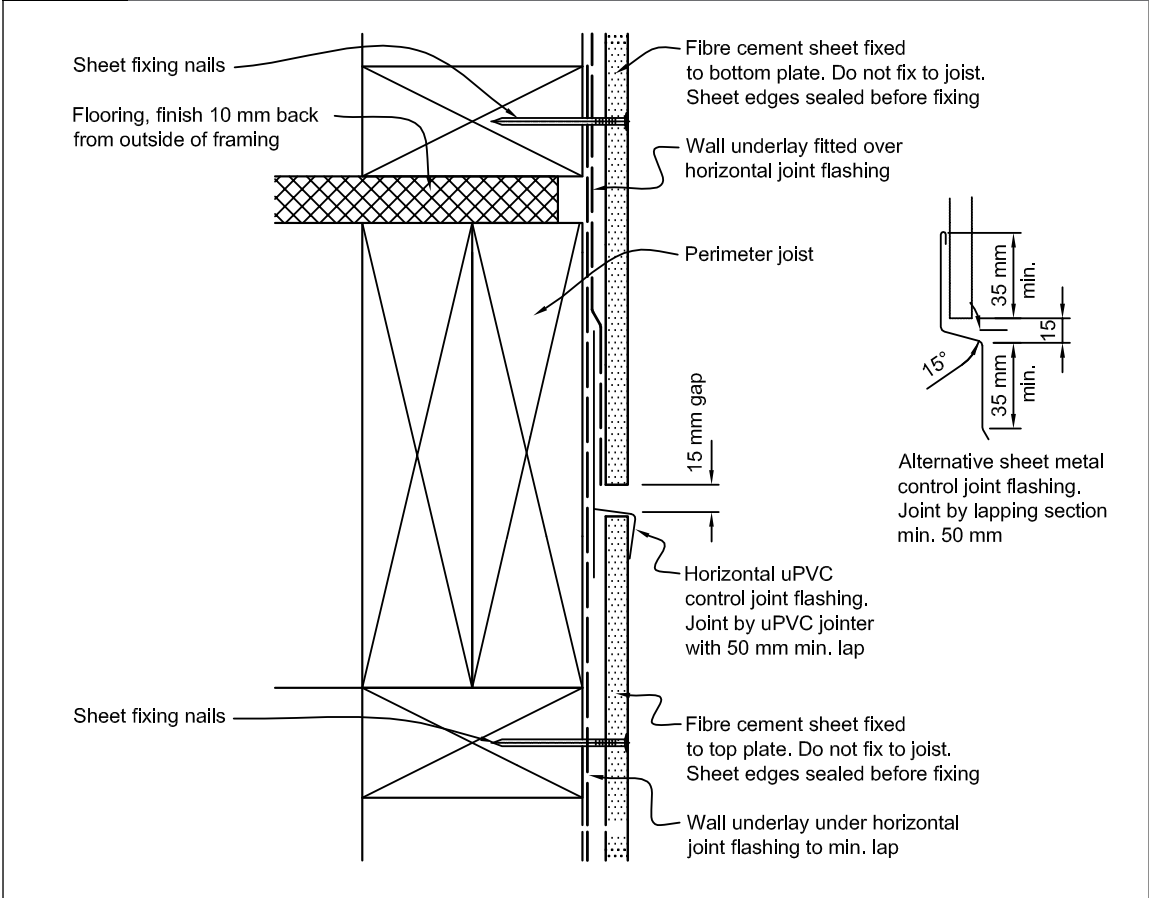

Amend 5
Aug 2011

Figure 108: Horizontal joints for fibre cement sheet on cavity
Paragraph 9.7.3

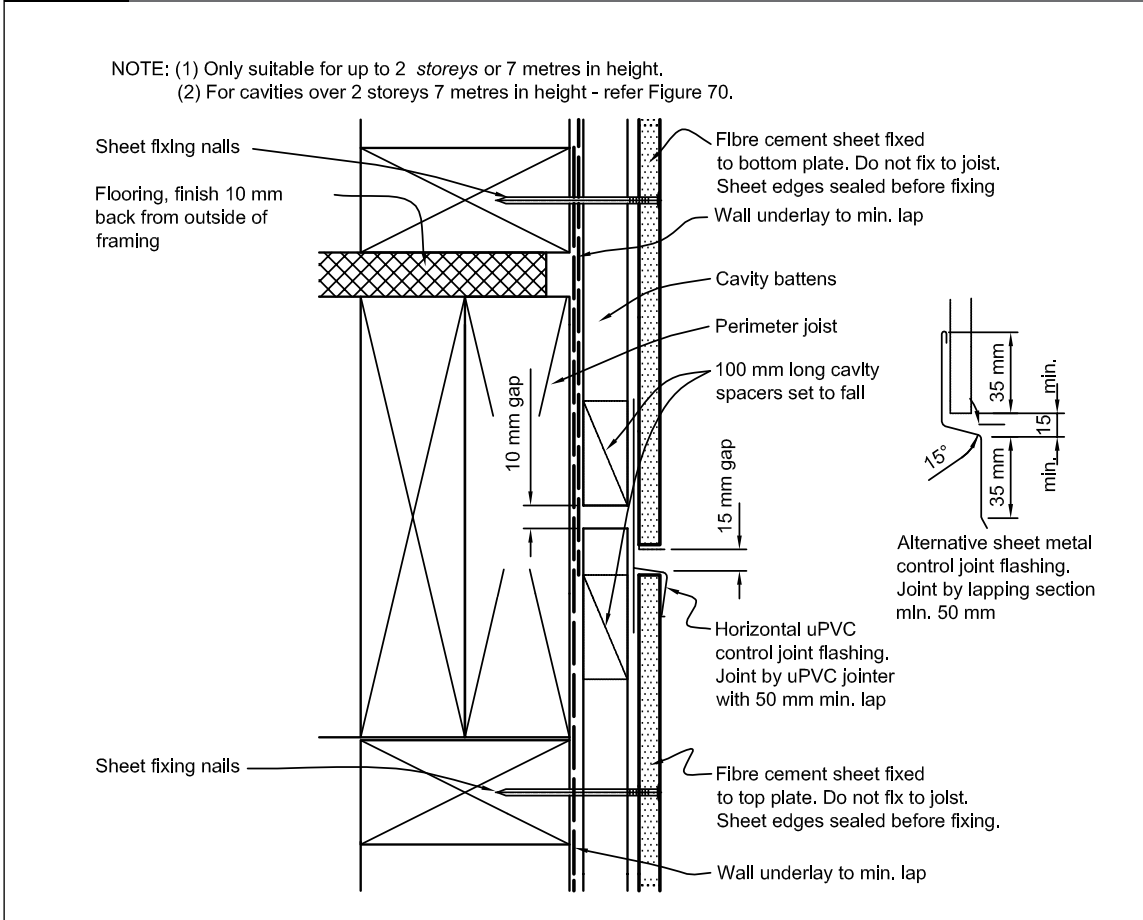

9.7.3.1 Paint finish

For jointed systems, all sheet edges shall be sealed prior to fixing. Fibre cement shall be finished with a latex exterior paint system complying with any of Parts 7, 8, 9 or 10 of AS 3730.

9.7.4 Flush-finished systems

Flush-finished systems shall be constructed over a drained cavity outlined in Paragraph 9.1.8.

- a) Flush-finished joints shall be finished with a textured finish system that:
 - i) complies with BRANZ EM 4, when tested with the specific fibre cement substrate and jointing system used for the cladding
 - ii) has all components approved by the supplier of the jointing and finish system

- iii) where a topcoat of paint over the finish is required to provide weather protection, is a latex exterior paint system complying with any of Parts 7, 8, 9 or 10 of AS 3730.
- b) Joints shall be positioned so that they:
 - i) do not occur at corners of window or door openings or at changes in the height of a wall
 - ii) are a minimum of 200 mm on either side of the jamb-line of an opening
 - iii) detailed as shown in Figure 110.
- c) External corners shall use uPVC corner reinforcement beneath tape and finishing compound as shown in Figure 113.
- d) Internal corners shall use a sealant-filled joint over compressible foam tape as shown in Figure 111 b) with polyethylene bond breaker tape behind joint.

Amend 5
Aug 2011

Amend 5
Aug 2011

Figure 109 deleted

9.7.4.1 Control joints

Vertical *control joints* shall be located as shown in Table 19, and:

- a) May occur at the edge of window or door openings,
- b) Shall extend the full height of the *wall*, including where there is a horizontal joint and a vertical *control joint* on the *wall* – refer to Figure 111, and
- c) May be staggered across horizontal *control joints*.

| Table 19: Control joints for flush-finished fibre cement Paragraph 9.7.4.1, Figure 111 | |
|---|---|
| Vertical control joints | Horizontal control joints |
| 5400 mm centres max. (6000 mm allowed on walls that finish at an exterior corner) | 5400 mm centres max. (on <i>dwangs</i> between full-height, continuous studs) |
| All internal corners | All floor joist locations |

NOTE: Non-*flush-finished* joints are *control joints*.

9.7.4.2 Finishes

Finish colour shall have a reflectance of 40% or more, as outlined in Paragraph 2.4.

9.7.5 Soffit details

Soffits shall be detailed as shown in Figure 114 for *flush-finished* and Figure 8A for jointed.

9.7.6 Windows and doors

Windows and doors shall be installed in accordance with Paragraph 9.1.10 and:

- a) *Direct fixed* windows and doors shall be detailed as per Figure 115
- b) Windows and doors on cavity shall be detailed as per Figure 116.

9.7.7 Parapets and enclosed balustrades

Parapets shall comply with Paragraph 6.0.

Enclosed balustrades shall comply with Paragraph 7.4.

Balustrade cappings may include:

- a) Metal, butyl or *EPDM* to Paragraph 6.3, or,
- b) *Flush-finished* fibre cement to Paragraph 9.7.7.1 and Figure 117.

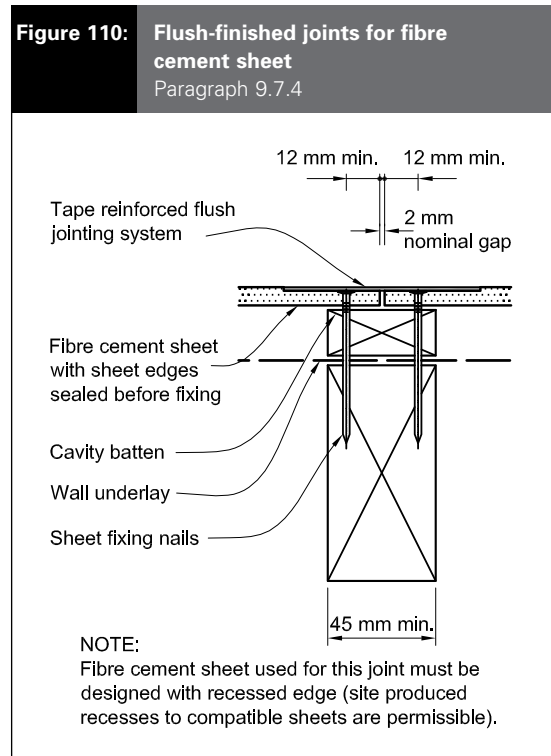
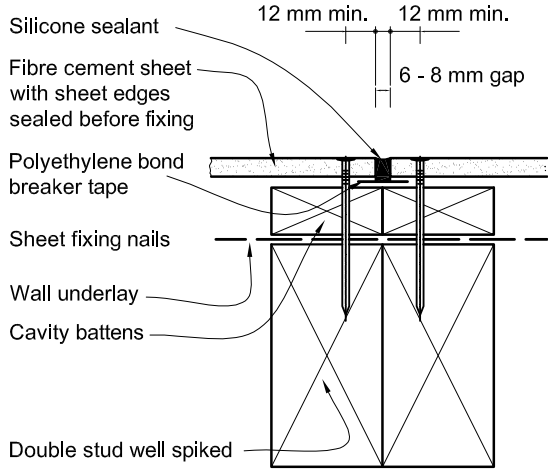

Figure 111: Vertical movement control joint for flush-finished fibre cement sheet
Paragraph 9.7.4.1

NOTE:

- (1) Fibre cement sheet to be sealed including all edges before fixing batten.
- (2) Do not apply paint over sealant. If texture coated, use polyethylene bond breaker tape.



(a) SHEET JUNCTION CAVITY FIX

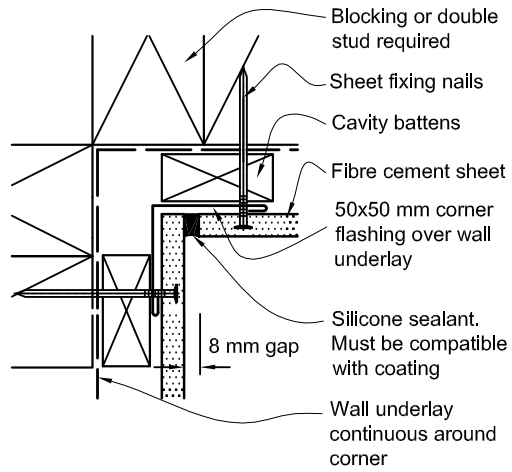

(b) INTERNAL CORNER CAVITY FIX

Amend 5
Aug 2011

Figure 112 deleted

Figure 113: Flush-finished external corners for fibre cement sheet
Paragraph 9.7.4

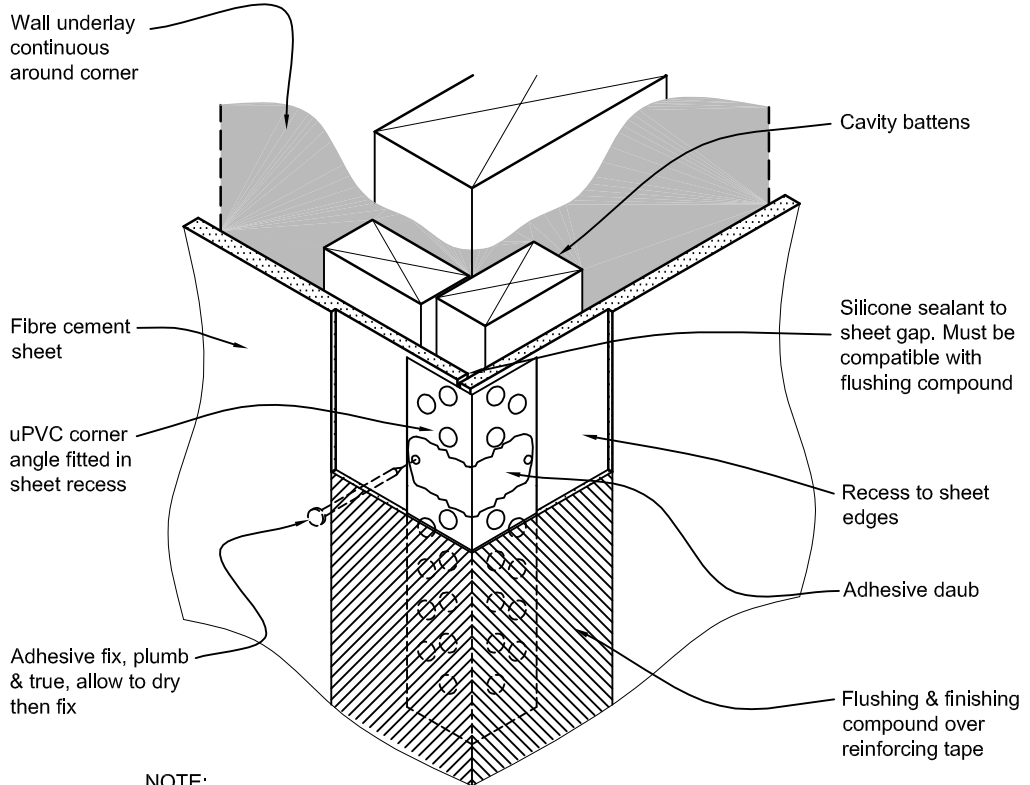

NOTE:
(1) Fibre cement sheet used for this joint must be designed with recessed edge (site produced recesses to compatible sheets are permissible).
(2) Internal corners similar.

Amend 2
Jul 2005

Amend 5
Aug 2011

Figure 114: Soffit for flush-finished fibre cement sheet
Paragraph 9.7.5

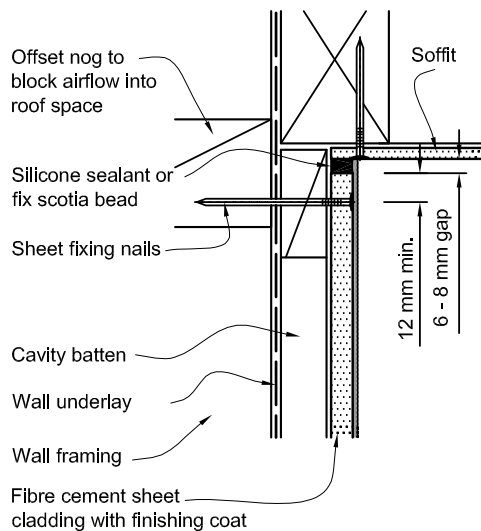

Amend 5
Aug 2011

Figure 115: Windows and doors for direct fixed fibre cement sheet
Paragraph 9.7.6

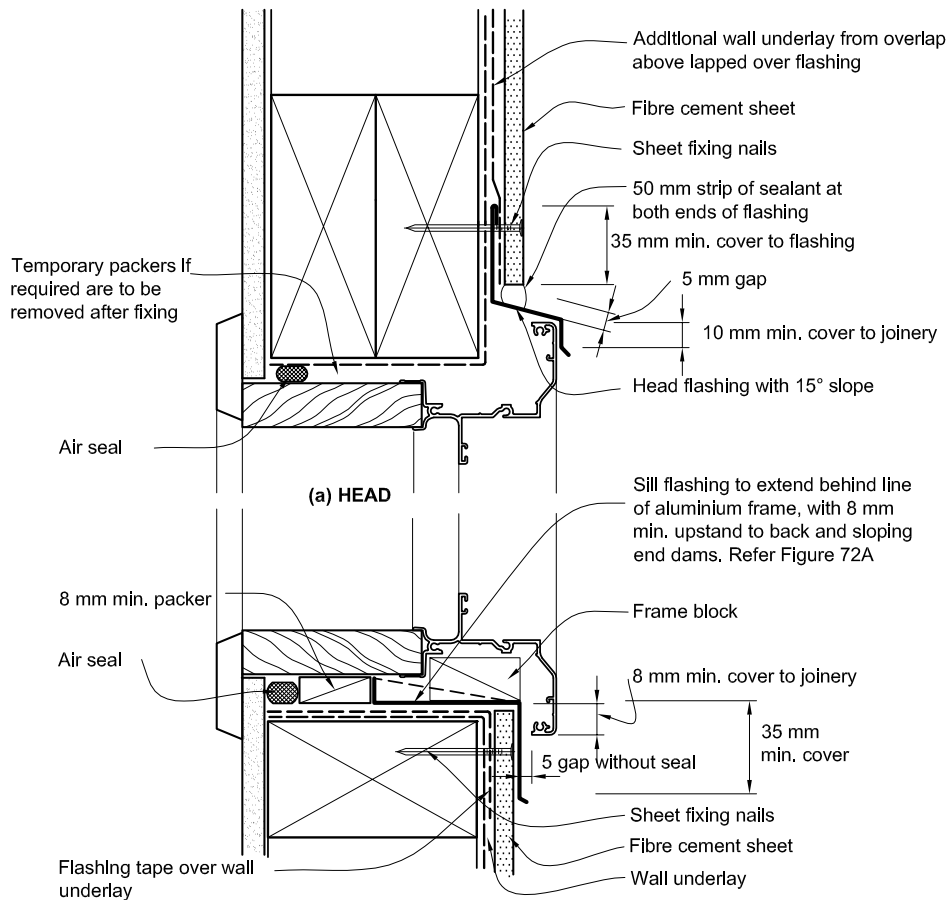

NOTE:
 (1) Window profile to be selected to achieve cover shown in details.
 (2) Architraves are shown for consistency only, detail may be used with rebated liner.
 (3) Refer Figure 72A for wrapping of framed opening prior to window installation.

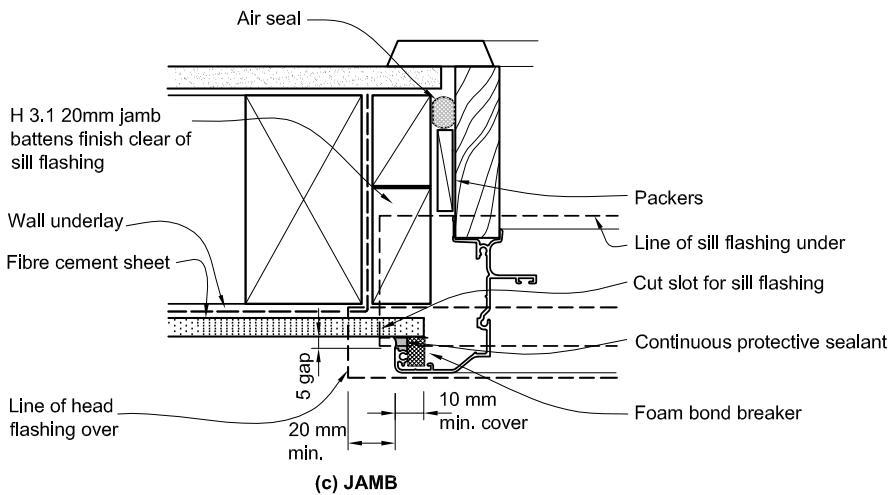

Amend 5
Aug 2011

Amend 2
Jul 2005

Figure 116: Windows and doors for fibre cement sheet and flush-finished fibre cement on cavity
Paragraph 9.7.6

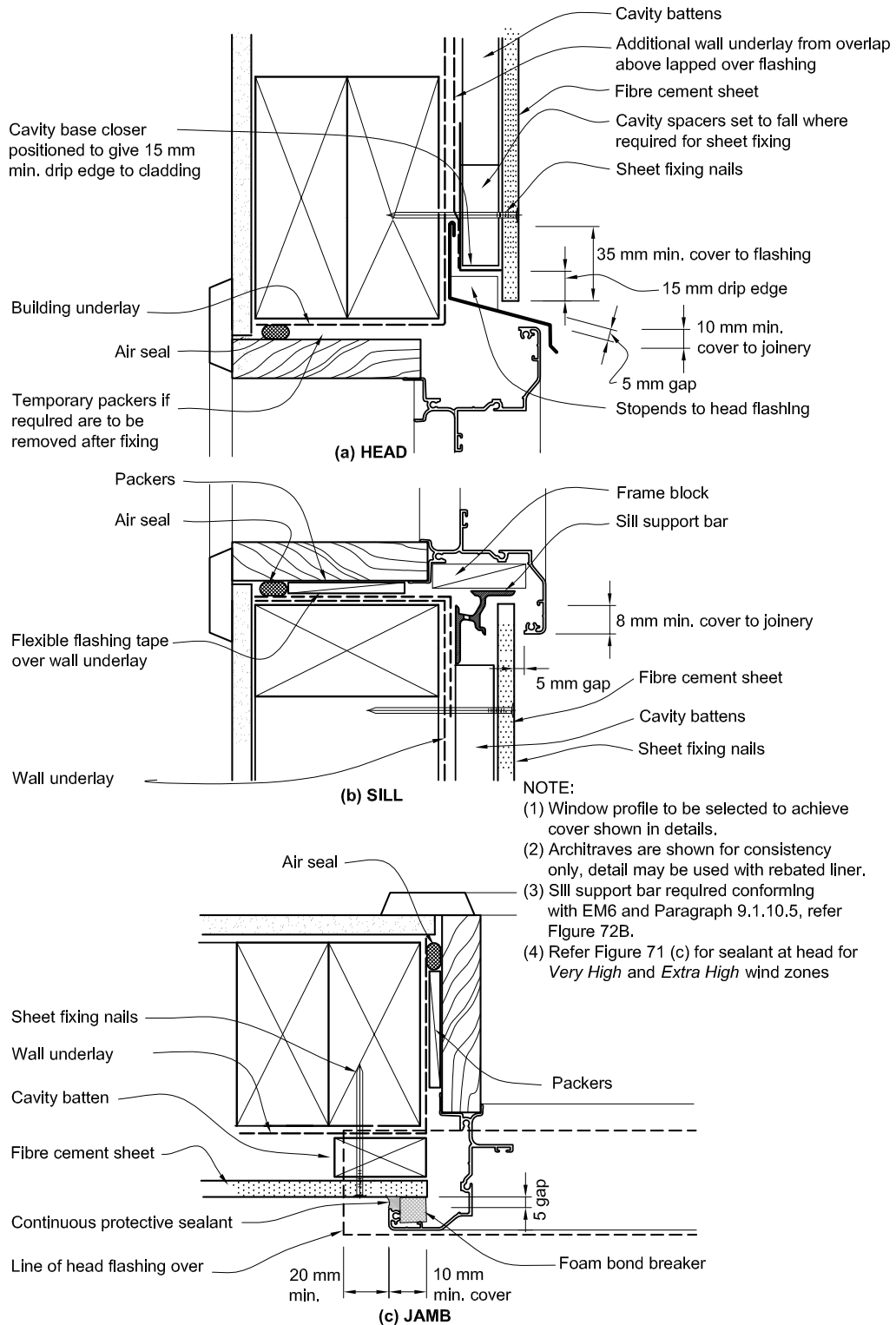

Amend 5
Aug 2011

Amend 2
Jul 2005

9.7.7.1 Flush-finished topped balustrades

Amend 2
 Jul 2005

Where the tops to *enclosed balustrades* are formed using *flush-finished* fibre cement, they shall have a minimum fall of 10° (1:6), and be wrapped as shown in Figure 117, with a *waterproofing membrane*, approved by the supplier of the jointing and finish system. The *membrane* shall be fully protected by the coating and shall comply with the requirements of AS/NZS 4858 Table 8, Parts (a) to (e), except that bleach and detergent immersion set out in Appendix A1 shall not be required.

Amend 2
 Jul 2005

Amend 5
 Aug 2011

Amend 2
 Jul 2005

Figure 117: Enclosed balustrade to wall for fibre cement sheet
 Paragraphs 6.6 and 9.7.7.1

NOTE: (1) Refer Figure 11 and Figure 12 for details of *framing* and bridge over cavity.
 (2) Flush finish fibre cement balustrades only permitted with cavity construction - refer 9.1.8.

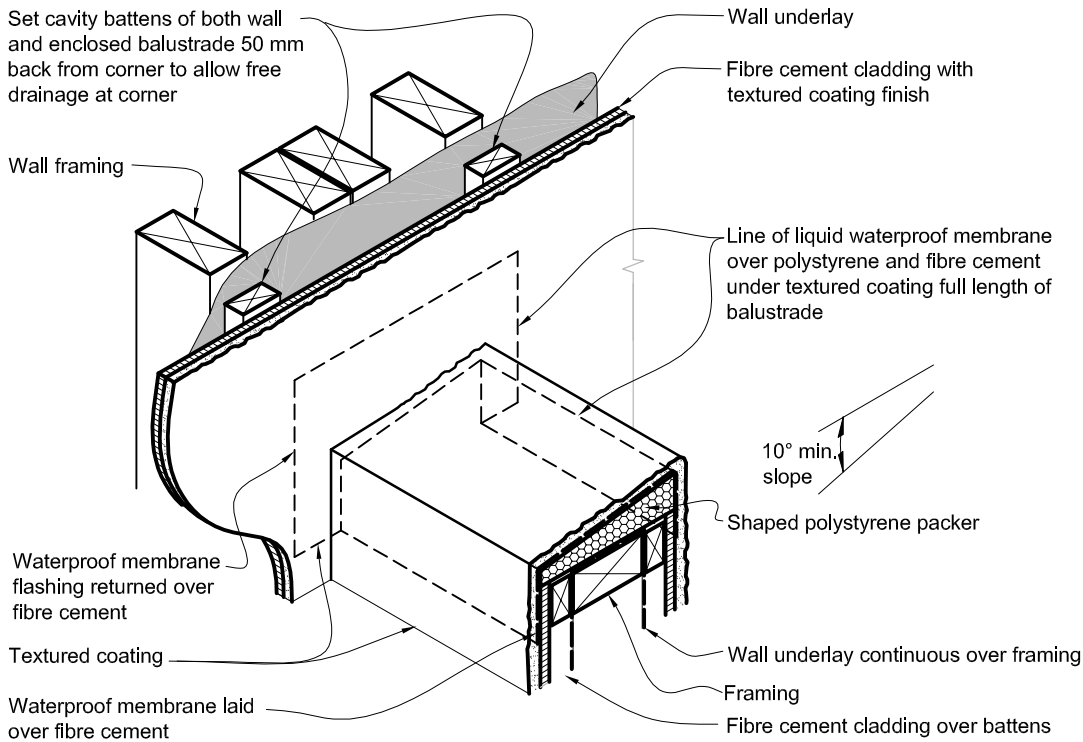

Figure 118 deleted

Amend 5
 Aug 2011

9.7.8 Decorative attachments

Where decorative attachments are used, seal sheets prior to attachment of the decorative elements. The final weatherproofing system shall be applied over decorative elements and *wall cladding*. Horizontal decorative elements shall have top surfaces sloped to a minimum of 10° and drip mouldings to bottom edges.

Attachments shall not interfere with the functioning of critical joints such as *control joints*.

COMMENT:

Alternatively, a decorative moulding may be formed from the coating by using mesh and plaster.

9.8 Plywood Sheet

Amend 5
Aug 2011

Plywood-sheet *claddings* shall be either *direct fixed* to *framing* over a *wall underlay* or fixed over a *drained cavity* as per Paragraph 9.1.8.

Based on the *risk score* for an *external wall*, calculated as per Paragraph 3.1, the sheet *cladding* may require the inclusion of a *drained cavity*.

9.8.1 Limitations

This Acceptable Solution covers plywood panel *claddings* with vertical battened joints and flashed horizontal joints.

Figure 118 deleted

Amend 5
Aug 2011

9.8.2 Materials

Amend 5
Aug 2011

Batten-jointed panels shall have weather-grooved timber battens as shown in Figure 119.

Plywood panels shall be:

- a) Manufactured to AS/NZS 2269, grade CD,
- b) A minimum of 5 ply,
- c) A minimum of 12 mm in thickness, and
- d) Treated as required by NZS 3602.

9.8.3 Installation

A *wall underlay*, as specified in Table 23, shall be installed behind plywood sheet *claddings*.

COMMENT:

Refer to Paragraph 1.5 for qualification of installers.

Amend 5
Aug 2011

9.8.3.1 Fixings

Plywood sheets shall be fixed through the *wall underlay* into the *wall framing* with fixings as required in Table 24.

Amend 5
Aug 2011

9.8.3.2 Joints

All joints shall:

Errata 2
Dec 2011

- a) Be made only over supports, and
- b) If horizontal, incorporate a 10 mm expansion gap, and be fitted with a *flashing*, as shown in Figure 121, or
- c) If vertical, have battened joints – refer to Figure 119.

Amend 5
Aug 2011

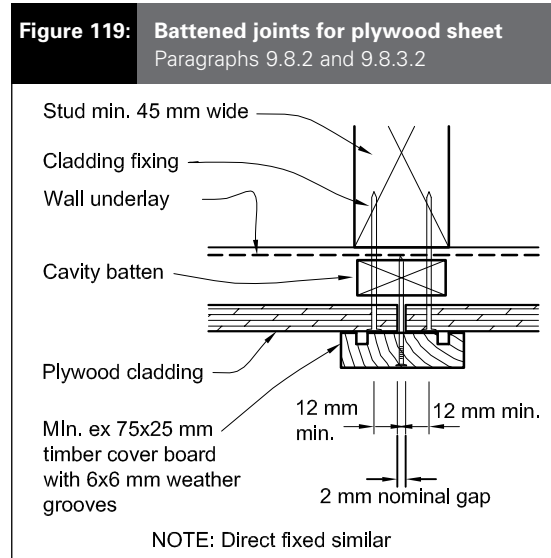
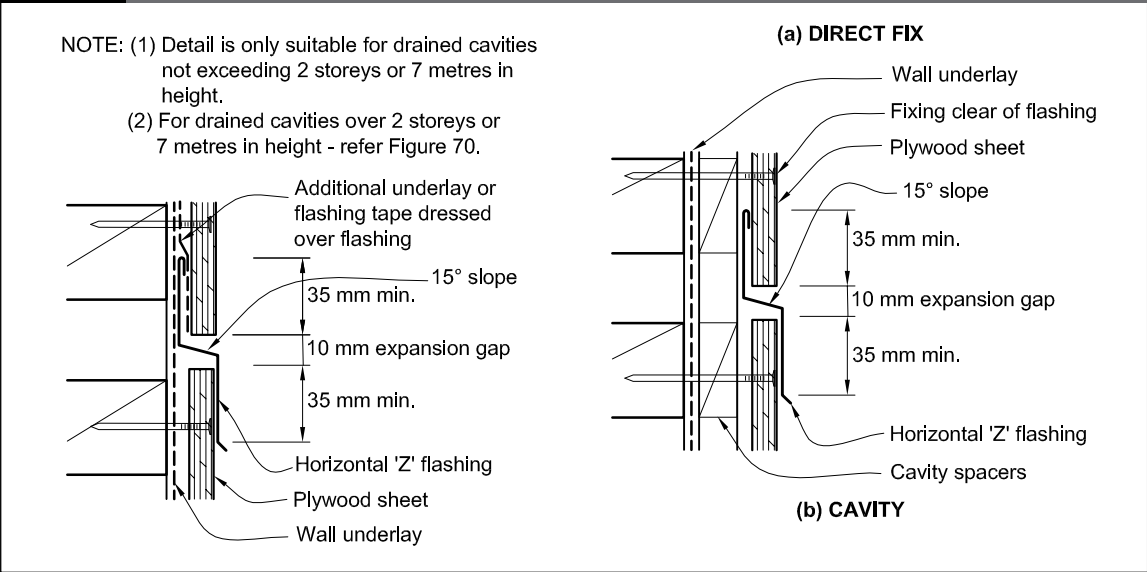

Figure 120 deleted

Amend 5
Aug 2011

Figure 121: Horizontal joints for plywood sheet
Paragraph 9.8.3.2



Amend 5
Aug 2011

9.8.4 Corners

9.8.4.1 External corners

Amend 5
Aug 2011

External corners shall be fitted with *flashings* or timber battens, as shown in Figure 122.

9.8.4.2 Internal corners

Internal corners shall be as shown in Figure 123 and have:

- Flashings* and timber battens for direct fix
- Timber battens for cavity fix.

Amend 5
Aug 2011

9.8.5 Flashing material

Flashings shall be metal selected in accordance with Table 20 to Table 22 and Paragraph 4.3.

Amend 5
Aug 2011

9.8.6 Soffit details

Soffits shall be as shown in Figure 8A and Paragraph 5.3.

Amend 5
Aug 2011

9.8.7 Parapets and enclosed balustrades

Parapets and *enclosed balustrades* shall be capped with metal, butyl or *EPDM membrane*. *Cappings* shall comply with the requirements of Paragraph 4.0.

- Parapets* shall be in accordance with Paragraph 6.0
- Enclosed balustrades* shall be in accordance with Paragraph 7.4.

Amend 5
Aug 2011

9.8.8 Windows and doors

Windows and doors shall be installed in accordance with Paragraph 9.1.10.

9.8.8.1 Windows and doors: direct fixed

Windows and doors shall be detailed as shown for fibre cement sheet *cladding* – refer to Figure 115.

Amend 5
Aug 2011

9.8.8.2 Windows and doors: with cavity

Windows and doors shall be detailed as shown for fibre cement sheet *cladding* – refer to Figure 116.

Amend 5
Aug 2011

COMMENT:

The same principles of window installation apply to both fibre cement and plywood sheet *cladding*.

9.8.9 Finishes

A solution of 12.5% copper naphthenate in white spirits, or mineral turpentine, shall be brushed on to any edges cut after treatment.

Direct fixed plywood *cladding* used as bracing requires a minimum 50-year *durability*, and shall be treated to H3, painted on all edges and the outer face with a latex exterior paint system complying with any of Parts 7, 8, 9 or 10 of AS 3730.

Amend 5
Aug 2011

Amend 5
Aug 2011

COMMENT:

Plywood for *cladding*, treated to H3, does not require painting.

While H3 plywood can be left unpainted, it is likely to develop checking and mould growth on the surface.

Plywood used as bracing requires painting and regular maintenance of the paint finish to ensure the 50-year *durability* is achieved.

Amend 5
Aug 2011

Amends
2 and 5

Amend 5
Aug 2011

Figure 122: External corners for plywood sheet
Paragraph 9.8.4.1

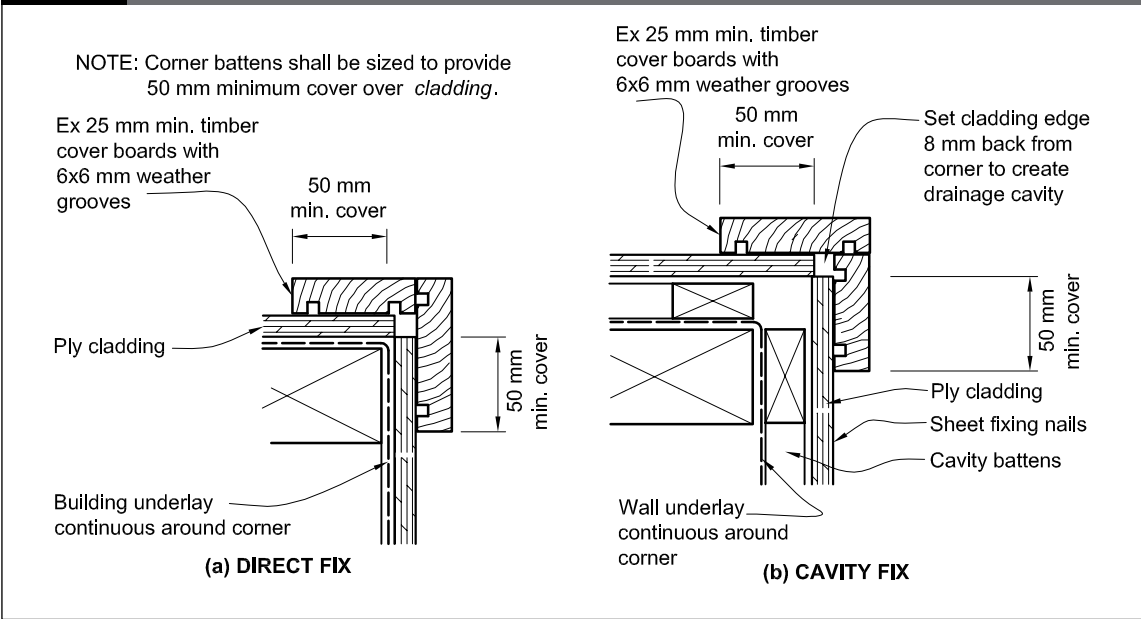

Amend 5
Aug 2011

Figure 123: Internal corners for plywood sheet
Paragraph 9.8.4.2

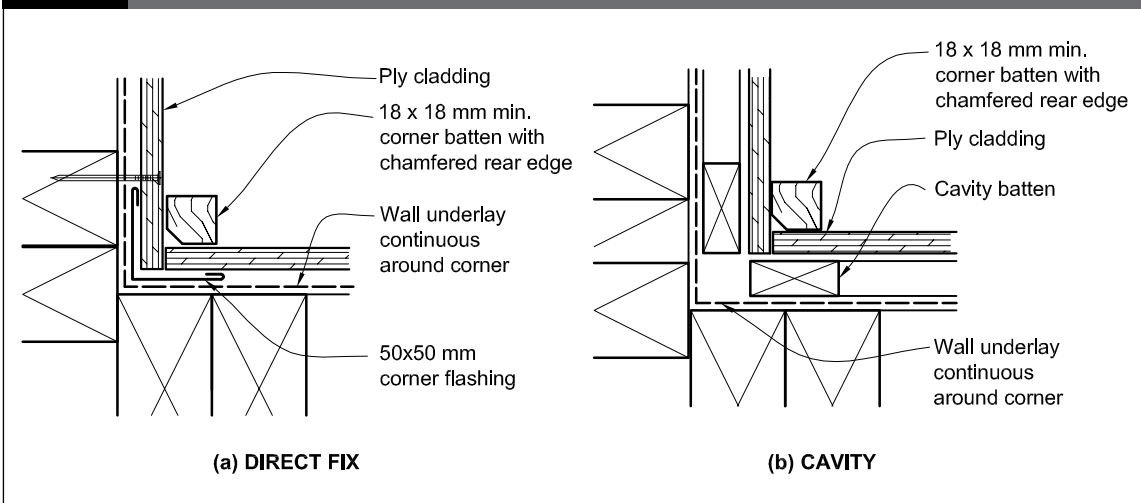

9.9 EIFS

This paragraph covers polymer-modified cement-based plaster or polymer-based polystyrene-based plaster Exterior Insulation and Finish Systems (*EIFS*).

EIFS cladding shall be fixed over a *drained cavity* as described in Paragraph 9.1.8.

Amend 5
Aug 2011

9.9.1 Limitations

This Acceptable Solution is limited to *EIFS cladding systems* that are:

- a) Designed and tested as a total system, and
- b) Not fixed:
 - i) so as to form a horizontal surface,
 - ii) as a replacement for roofing, or
 - iii) in such a way as to allow water to pond.

Amend 2
Jul 2005

9.9.2 General**COMMENT:**

Refer to Paragraph 1.5 for qualification of installers.

Amend 5
Aug 2011

9.9.3 Materials

EIFS cladding systems shall comprise the following parts:

- a) A polystyrene sheet *cladding material*,
- b) A polymer-modified cement-based plaster or a polymer-based plaster, reinforced with fibreglass mesh,
- c) A polymer-modified cement or polymer-based finishing plaster, and a latex exterior paint system complying with any of Parts 7, 8, 9 or 10 of AS 3730,
- d) A range of head, sill, jamb, corner and base mouldings suitable for exterior use, and
- e) A flexible polymeric neutral cure sealant that:

- i) is approved by the *cladding system* supplier, and
- ii) complies with:
 - a. Type F, Class 20LM or 25LM of ISO 11600, or
 - b. low modulus Type II Class A of Federal Specification TT-S-00230C.

COMMENT:

This is the minimum standard, and extra elements deemed suitable by the system supplier should not be excluded on the basis of this Acceptable Solution.

9.9.3.1 Polystyrene sheet

Polystyrene sheet shall be a minimum of 40 mm thick and shall be either:

- a) Expanded polystyrene (EPS) complying with AS 1366: Part 3, Class H or Class S, or
- b) Extruded polystyrene (XPS) that complies with AS 1366: Part 4.

9.9.3.2 Fibreglass reinforcing mesh

Fibreglass reinforcing mesh shall be alkali-resistant fibreglass mesh, and shall:

- a) Weigh no less than 150 grams per m²,
- b) Have an aperture size from 3 mm x 3 mm to 6 mm x 6 mm square, and
- c) Comply with the requirements of EIMA 101.9 test No. 6.3 and ASTM E2098.

9.9.4 Installation

A *wall underlay*, as specified in Table 23 and Paragraphs 9.1.5–9.1.7, shall be fixed to the *framing*.

Amend 5
Aug 2011

9.9.4.1 Fixings

Polystyrene sheets shall be fixed through the *cavity battens*, and *wall underlay* into the *wall framing* with fixings as required in Table 24. Fixings shall:

Amend 5
Aug 2011

- a) Be spaced as shown in Table 24,
- b) Penetrate the *framing* by 30 mm minimum,
- c) Comply with AS/NZS 4680, and
- d) Be either:
 - i) hot-dipped galvanized springhead nails with a 22 mm top, or
 - ii) hot-dipped galvanized flat head nails used in conjunction with a 22 mm minimum diameter plastic washer.

9.9.4.2 Joints

Amend 5 Aug 2011 | Joints to plain-edged sheets shall be butt jointed over solid timber backing.

Rebated or tongued boards may be jointed away from solid timber backing, providing the joint is self-supporting at both edges.

Corner joints shall be butted together and fully supported along the length of the joint.

9.9.4.3 Movement control joints

Control joints shall always be located over solid timber backing. *Control joints* shall be as shown in Figure 124, and shall be provided:

Amend 5 Aug 2011 | a) On all walls over 20 metres long or over 7 metres high including gables,

COMMENT:

The system supplier may require *control joints* at closer spacings.

- b) At abutments to different *cladding* types,
- c) Where *cladding* covers different structural materials such as timber to concrete, and
- d) Over a movement *control joint* in the underlying *framing*.

9.9.4.4 Fixing blocks

Amend 5 Aug 2011 | H3.2 treated timber blocks shall be provided at appropriate locations for fixing all downpipe brackets, garden taps, and other outside fittings.

Amend 5 Aug 2011 | The blocks shall be cut to suit the polystyrene thickness, and fixed to *framing* or *cavity battens*. Prior to applying the plaster basecoat, a patch shall be applied that:

- a) Extends over the timber block face and overlaps the adjacent polystyrene by a minimum of 50 mm, and
- b) Is suitable for the direct application of the base coat, and is either:
 - (i) a butyl-based *flexible flashing tape* that complies with Parts 3.2 and 4 of ICBO Acceptance Criteria AC148, or
 - (ii) a *waterproofing membrane* that complies with the requirements of AS/NZS 4858 Table 8, Parts (a) to (e), except that bleach and detergent immersion set out in Appendix A1 shall not be required.

The design of fixing blocks for connecting items carrying substantial loads such as stringers for *decks* are outside the scope of this Acceptable Solution. These will require *specific design*.

Amend 2 Jul 2005

Figure 124: Control joints for EIFS
Paragraph 9.8.4.3

NOTE:
(1) Detail (a) is for EIFS not exceeding 2 storeys or 7m in height.
(2) For EIFS exceeding 2 storeys or 7 m in height - refer Figure 70.

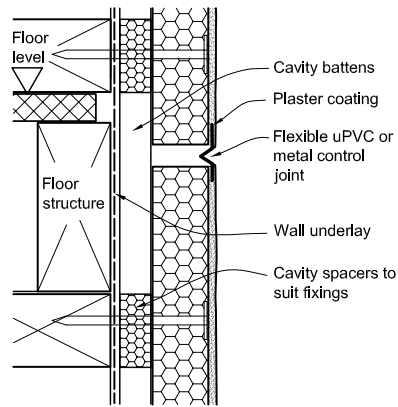

(a) HORIZONTAL CONTROL JOINT

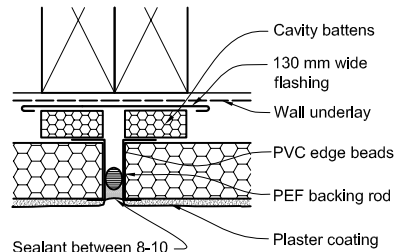

(b) VERTICAL CONTROL JOINT

Amend 2 Jul 2005

Amend 5 Aug 2011

Amend 5 Aug 2011

9.9.5 Battens

Cavity battens shall comply with Paragraph 9.1.8.4, installed as in Paragraph 9.1.8.

Amend 5
Aug 2011

COMMENT:

Cavity spacers must be short and sloped to prevent water being trapped by the battens and ventilation being restricted.

9.9.6 Coating

Suppliers of *EIFS cladding systems* shall demonstrate that their systems meet the tensile-adhesion performance requirements of ASTM E2134.

9.9.6.1 Reinforcing

The entire surface of the polystyrene sheet (including corners) must be continuously reinforced with alkali-resistant fibreglass reinforcing mesh as specified in Paragraph 9.9.3.2.

9.9.6.2 Reinforcing base coat

The reinforcing base coat shall have:

- a) A base coat plaster at the greater of the system supplier's minimum recommended thickness or 3 mm thick, and be either:
 - i) polymer-modified cement-based, or
 - ii) polymer-based,
- b) Reinforcing with an alkali-resistant fibreglass mesh (Paragraph 9.9.3.2), and
- c) Cover to mesh by at least 1.5 mm plaster.

9.9.6.3 Finish coats

Finish colour shall have a reflectance of 40% or more, as outlined in Paragraph 2.4.

The finish shall comprise either:

- a) One or more coats of polymer-modified cement-based plaster or polymer-based plaster, or
- b) One or more coats of a pre-coloured polymer-modified cement-based plaster, or

- c) A pre-coloured polymer-based plaster applied according to the conditions specified by the plaster manufacturer.

Where necessary to maintain *weather-tightness*, *EIFS* shall be finished with a latex exterior paint system complying with any of Parts 7, 8, 9 or 10 of AS 3730.

Polymer-modified cement-based plaster shall only be applied out of direct sunlight and when the temperature is between 5°C and 30°C, with the expectation that the temperature will be in that range for the following 24 hours.

9.9.6.4 Decorative mouldings

Decorative mouldings shall be formed from polystyrene, and shall be glued or mechanically fastened to ensure they remain securely attached to *EIFS cladding* or *framing*.

Where decorative mouldings are attached, the basecoat shall be applied before the moulding.

COMMENT:

Alternatively, a decorative moulding may be formed from the coating by using mesh and plaster.

Amend 5
Aug 2011

Amend 5
Aug 2011

9.9.7 EIFS/floor slab junction

The bottom of the *EIFS cladding* shall be as shown in Figure 125.

9.9.8 Pipes and service penetrations

All pipes and service penetrations through the *EIFS* shall be made weatherproof, by either:

- a) A flange penetrating the *EIFS* as a sleeve and sealed into the *EIFS* system as shown in Figure 126, or
- b) A face-fitted flange at *EIFS* surface, sealed with a neutral cure sealant complying with:
 - i) Type F, Class 20LM or 25LM of ISO 11600, or
 - ii) low modulus Type II Class A of Federal Specification TT-S-00230C.

- c) Pipe penetrations shall be installed to slope downwards to exterior. Refer to Figure 68 or 69.

Where cables penetrate *cladding*, a sleeve or conduit shall be provided and sealed into the *EIFS* system. All wires that pass through a conduit shall be sealed into position inside the conduit.

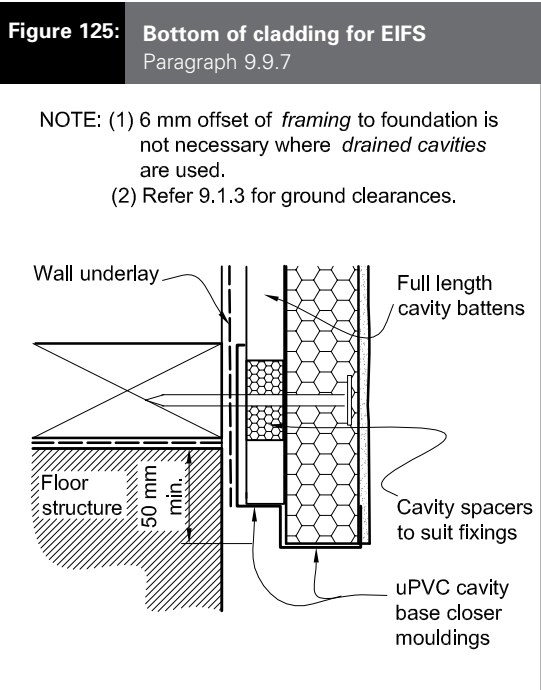

Amend 5
Aug 2011

Amend 5
Aug 2011

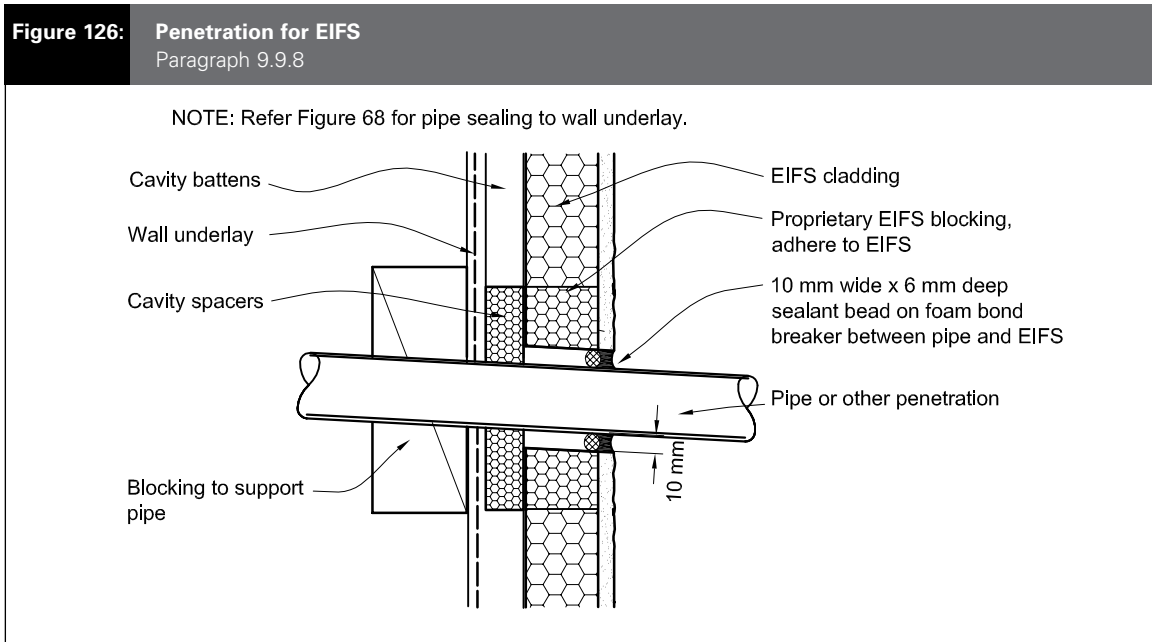

Amend 5
Aug 2011

9.9.9 Windows and doors

Windows and doors shall be installed in accordance with Paragraph 9.1.10, and shown in Figures 17C, 127 and 128.

Install uPVC three-way corner *flashings* at jamb/sill junctions as shown in Figure 127. Corner *flashings* shall be installed behind *EIFS* jamb and sill *flashings*, with flanges turned out over polystyrene backing sheets.

9.9.10 Parapets and enclosed balustrades

Parapets shall comply with Paragraph 6.0.

Enclosed balustrades shall comply with Paragraph 7.4.

9.9.10.1 Flush-finished balustrade top

Where the tops to *enclosed balustrades* are formed using *EIFS*, they shall have a minimum fall of 10° (1:6), and be wrapped as shown in Figure 129 and 130, with a liquid *waterproofing membrane* approved by the supplier. The *EIFS* system shall be fully protected by the coating, and shall comply with the requirements of AS/NZS 4858 Table 8, Parts (a) to (e), except that bleach and detergent immersion set out in Appendix A1 shall not be required.

Amend 2
Jul 2005

Amend 5
Aug 2011

9.9.10.2 Metal cappings

Metal *cappings* shall comply with the requirements of Paragraph 6.4, and shall be as shown in Figure 130.

Where a *parapet* or an *enclosed balustrade* meets *EIFS* wall *cladding*, a *saddle flashing* shall be used, as shown in Figure 12 and Figure 13.

Amend 2
Jul 2005

Figure 127: Window and door corner flashing for EIFS
Paragraph 9.9.9

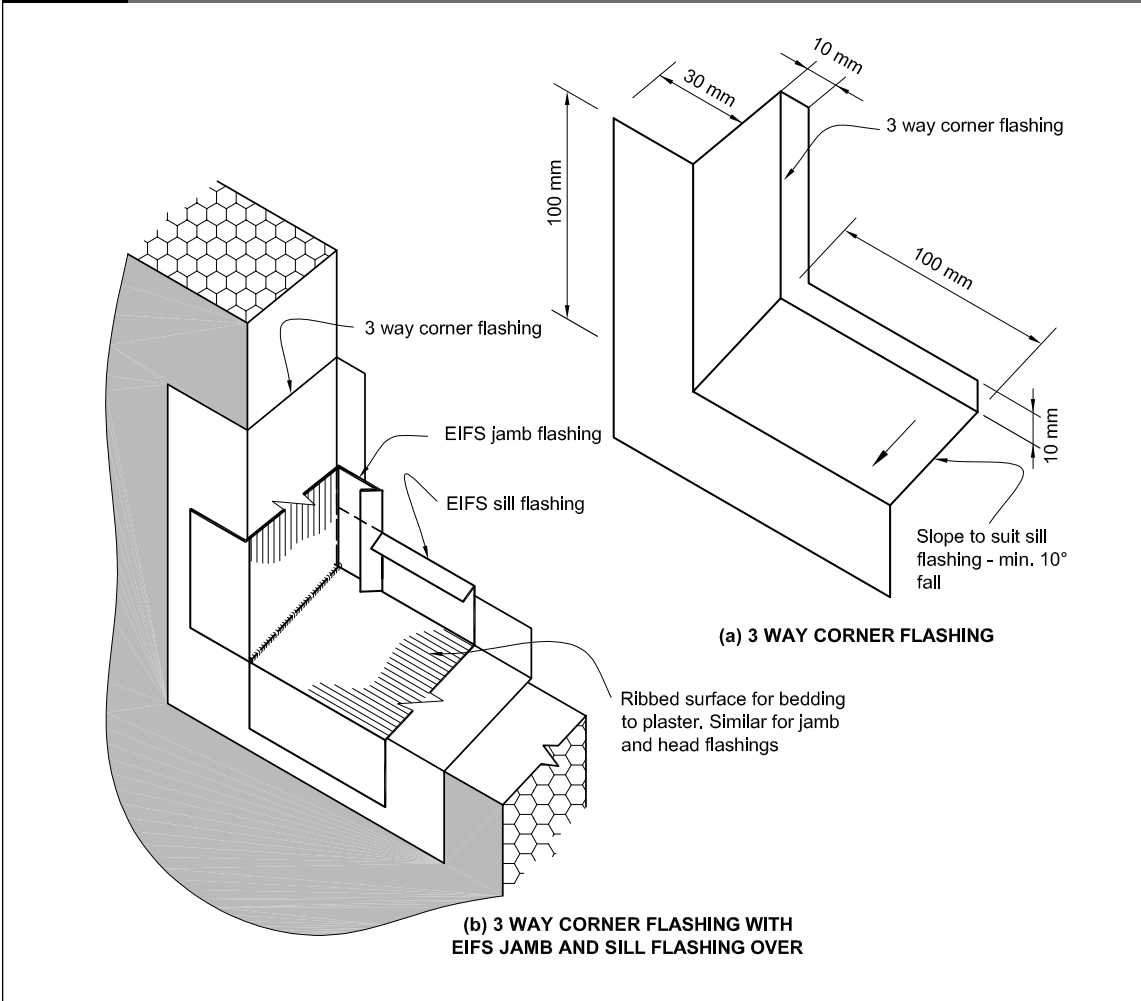

Amend 5
Aug 2011

Figure 123: Windows and doors in EIFS
Paragraph 9.9.9

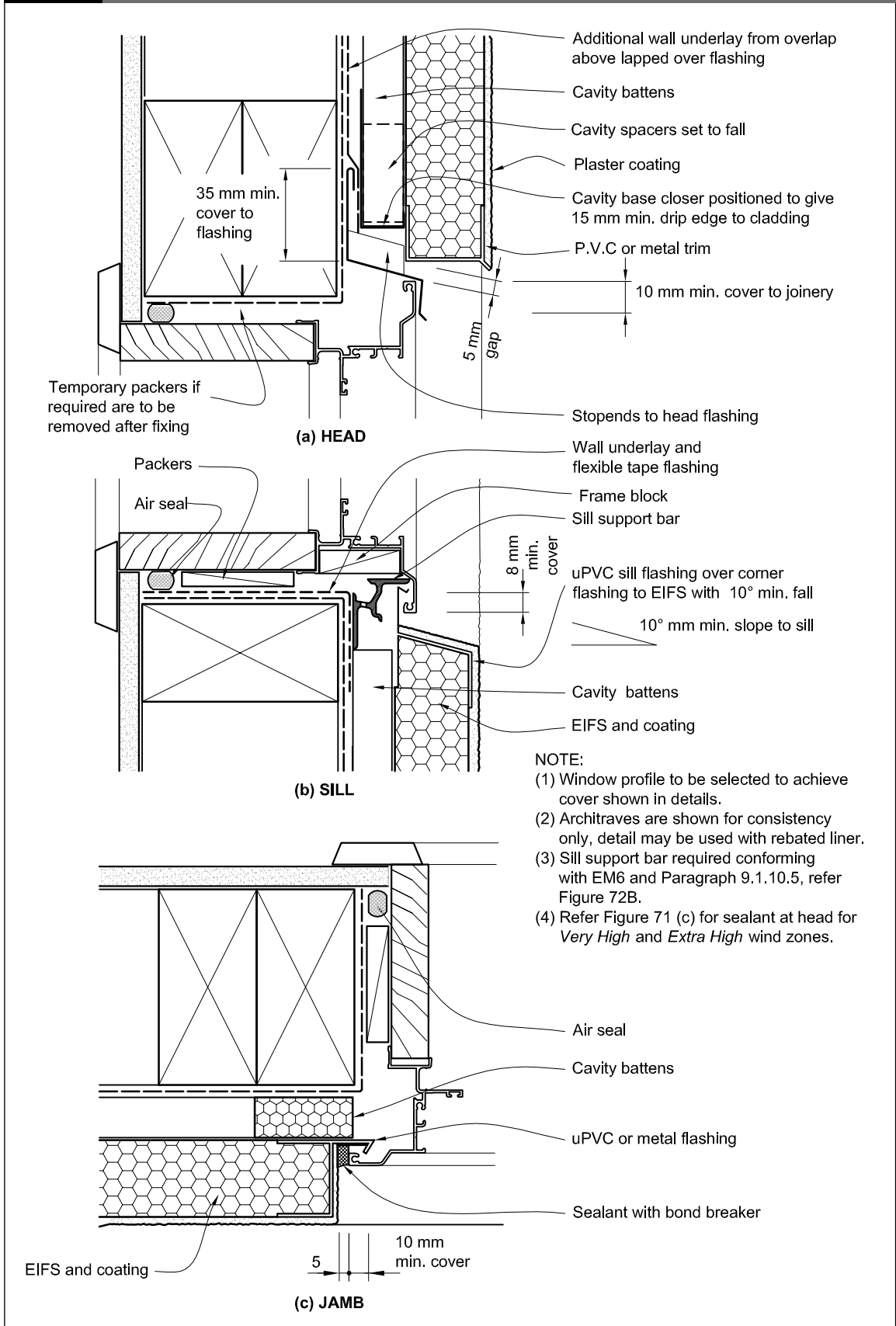

Amend 2
Jul 2005

Amend 5
Aug 2011

Figure 129: Enclosed balustrade-to-wall junction for EIFS
 Paragraphs 6.6 and 9.9.10.1

NOTE: Refer Figure 11 to Figure 13 for *framing* and *bridge over drained cavity*.

Set cavity battens of both wall and enclosed balustrade 50 mm back from corner to allow free drainage at corner

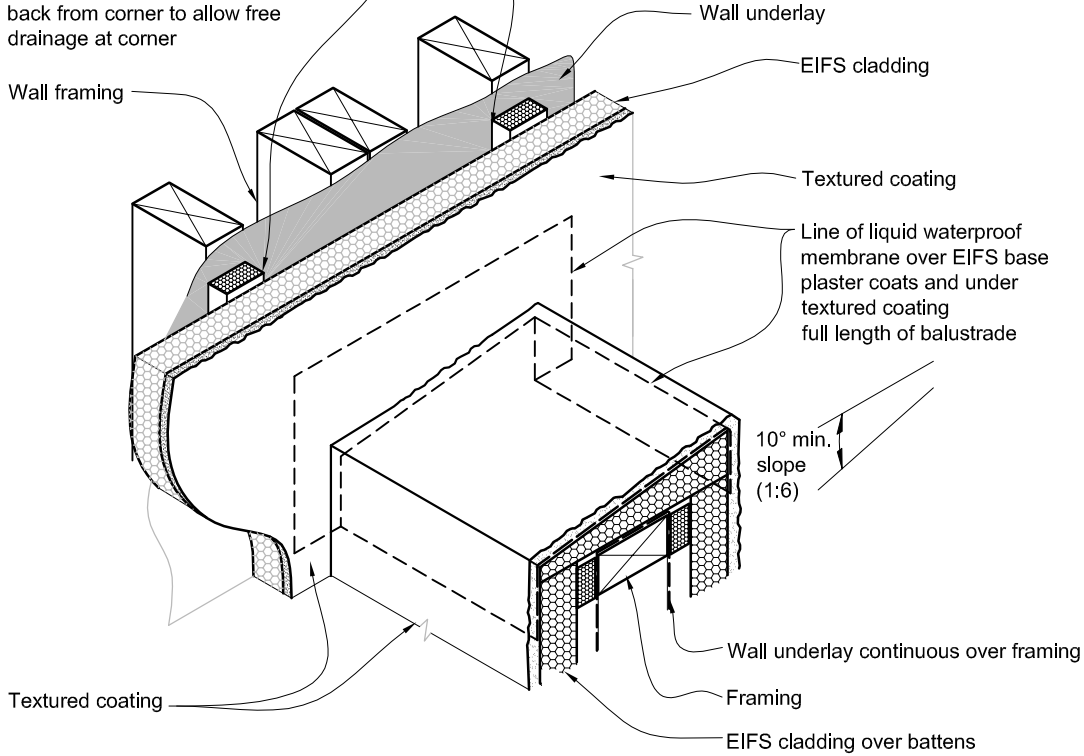

Amend 5
 Aug 2011

Figure 130: Parapet with metal capping for EIFS
 Paragraph 9.9.10.2

Underlay to provide separation of metal capping and timber

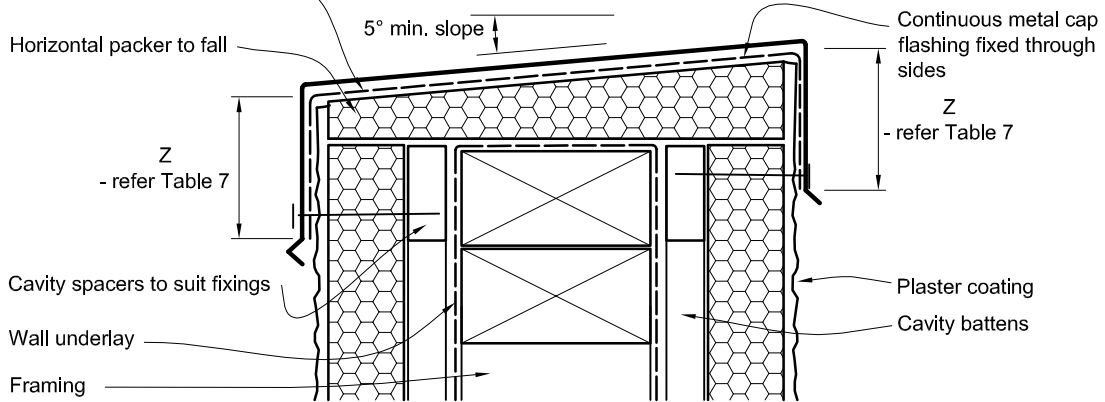

Amend 5
 Aug 2011

10.0 Construction Moisture**10.1 Moisture in materials**

Moisture contained in the *building* structure at completion of *construction* shall not be permitted to damage the *building elements*.

Construction moisture includes the moisture contained in:

- a) Timber products as a result of a treatment or manufacturing process,
- b) Green timber, and timber or other materials that have been exposed to the weather, and
- c) Concrete, mortar or plaster that is not completely cured.

10.2 Maximum acceptable moisture contents

The maximum moisture contents shall be:

- a) For timber *framing* at the time of installing interior *linings*, the maximum acceptable moisture content shall be the lesser of:
 - i) 20% for insulated buildings, 24% for non-insulated buildings, or
 - ii) as specified in NZS 3602,
- b) For timber weatherboards and exterior joinery, 20% at the time of painting,
- c) For reconstituted wood products, 18% at all times, and
- d) For concrete floors, sufficiently dry to give a relative humidity reading of less than 75% at the time of laying fixed floor coverings.

COMMENT:

Some manufacturers of timber or other wall or floor components may recommend lower moisture contents for their products.

It is advisable to use the manufacturer's moisture content requirements, if these are lower than those required by this paragraph.

10.3 Measuring moisture content**10.3.1 Timber**

Measurement shall be by the recommended procedure in the Scion (New Zealand Forest Research Institute) publication "Measurement of moisture content of Wood" using electrical resistance type moisture meters with insulated probes. Representative samplings of measurements shall be taken:

- a) With meters calibrated to AS/NZS 1080.1 Appendix E
- b) By inserting probes to at least 1/3 the depth of timber being measured, at a distance exceeding 200 mm from board ends
- c) Using correction factors for timber species, temperature, and treatment type (outlined in Scion publication above).

COMMENT:

For convenience of site measurement, readings of moisture content can be compared against a 'control' *framing* sample of known acceptable moisture content. The comparative readings must be taken during the same test period, be of the same framing type, and using the same resistance moisture meter. This method of moisture testing may be appropriate for non-boron treated *framing*, or processed timber *framing*.

10.3.2 Concrete floors

Measurement shall be made in accordance with BRANZ Bulletin 330 Thin Flooring Materials using hygrometers calibrated to ASTM E 104 – 2002 Standard practice for maintaining constant relative humidity by means of aqueous solutions.

Amend 5
Aug 2011Amend 5
Aug 2011Amend 5
Aug 2011Amend 5
Aug 2011Amend 5
Aug 2011

Table 20: Material selection

This table shall be read in conjunction with Table 21 and Table 22 and Paragraph 4.0.
Refer relevant *cladding* and *flashings* paragraphs for material and coating specifications.
Paragraphs 2.2, 4.2.1, 4.3.3, 4.3.4, 4.3.8, 4.3.10, 8.2.3, 8.2.4, 8.3.4.2, 8.4.3.1, 8.4.3.2, 9.1.10.2, 9.6.3.1, 9.6.3.2, 9.6.6 and 9.8.5

| Material | Exposure(1)(2)(4)(6) | | Acceptable Exposure Zones as per NZS 3604 – Section 4 (3)(4)(6) | |
|--|--|---------|--|------------------------------------|
| | NOTE: Consider all walls as 'Sheltered' for steel based claddings(8) | Type | 15 years | 50 years for hidden elements(2)(9) |
| CLADDINGS AND FLASHINGS | | | | |
| Aluminium, zinc | Hidden(2) | | B,C,D,E | B,C,D,E |
| | Exposed | | B,C,D,E | |
| | Sheltered | | B,C,D,E | |
| Copper, lead, or stainless steel | Hidden(2) | | B,C,D,E | B,C,D, E |
| | Exposed | | B,C,D,E | |
| | Sheltered | | B,C,D,E | |
| Factory painted | | | | |
| Aluminium-zinc coated or galvanised steel to AS/NZS 2728 (includes pre-painted tiles) | Hidden(9) | Type 4 | B,C,D,E | B,C,D |
| | Hidden(9) | Type 6 | B,C,D,E | B,C,D,E |
| | Exposed(8) | Type 4 | B,C,D | |
| | Exposed(8) | Type 6 | B,C,D,E | |
| | Sheltered | Type 4 | B,C | |
| | Sheltered | Type 6 | B,C,D | |
| Pressed metal tiles aluminium-zinc coated AZ150 to AS/NZS 2728 with post-form factory painting | Exposed | Type 6 | B,C,D,E | |
| | Sheltered | Type 6 | B,C,D | |
| Non-factory painted | | | | |
| Aluminium-zinc coated steel AZ150 to AS 1397. | Hidden(9) | | B,C,D,E | B,C,D |
| | Exposed(8) | | B,C | |
| | Sheltered | | B | |
| Galvanised steel Z450 to AS 1397 | Hidden(9) | | B,C,D | B,C |
| | Exposed(8) | | B,C | |
| | Sheltered | | B | |
| Non-metallic | | | | |
| Bituminous material, or uPVC | Hidden | | B,C,D,E | B,C,D,E |
| | Exposed (uPVC only) | | B,C,D,E | |
| | Sheltered (uPVC only) | | B,C,D,E | |
| Butyl rubber | Hidden | | B,C,D,E | B,C,D,E |
| | Exposed | | B,C,D,E | |
| | Sheltered | | B,C,D,E | |
| FIXINGS(7) | | | | |
| Aluminium, bronze, and stainless steel (Types 304 and 316)(10) | Hidden | | B,C,D,E | B,C,D,E |
| | Exposed | | B,C,D,E | |
| | Sheltered | | B,C,D,E | |
| Nails – Hot-dip galvanised steel to AS/NZS 4680 | Hidden(5)(9) | | B,C,D | B,C |
| | Exposed | | B,C, | |
| | Sheltered | | B | |
| Screws – galvanised steel, painted or unpainted, to AS 3566: Part 2 | Hidden(5)(9) | Class 3 | B,C,D,E(3)(4) | B,C,D,E |
| | Exposed | Class 4 | B,C,D | |
| | Sheltered | Class 4 | B,C | |

Errata 2
Dec 2011

Amend 5
Aug 2011

Table 20: Material selection – continued

Note:

- 1) Refer to manufacturer's information for maintenance requirements in Exposed and Sheltered locations.
- 2) The term "hidden" means concealed behind another element such that no part is visible. Hidden elements require a 50 year *durability* under the NZBC. The term "exposed" means having surfaces exposed to rain washing. The term 'sheltered' means being visible, but not rain washed. For diagrammatic outline, refer NZS 3604 Figure 4.3(a). Exposed and sheltered elements require a 15 year *durability*. Where an element can be categorised as both 'sheltered' and 'exposed', the 'sheltered' condition will apply.
- 3) AS/NZS 2728 lists atmospheric classes derived from ISO 9223 for Australia and New Zealand, determined by exposure to wind-driven sea-spray. NZS 3604 references atmospheric classes B (Low), C (Medium) and D (High). E2/AS1 references atmospheric zones B,C,D,E. For the purposes of *cladding* selection, Zone E (Severe marine classified as breaking surf beach fronts) has been included. Designers must consult metal supplier's information for specific *durability* requirements of sites in Zone E.
- 4) The geographic limits of atmospheric classes in NZS 3604 and AS/NZS 2728 may vary. Table 20 uses the limits outlined in NZS 3604.
- 5) Includes fixings protected by putty and an exterior paint system of primer, undercoat and two top coats of paint.
- 6) Microclimates based on evidence from adjacent structures of corrosion caused by industrial or geothermal atmospheres are outside the scope of this Acceptable Solution.
- 7) Refer to Tables 21 and 22 for compatibility of fixings with metal *claddings*.
- 8) *Roof* only. Coated steel *wall claddings* must be considered as 'sheltered'.
- 9) Hidden steel coated elements in ventilated cavities in zones D and E (exposure to salt air) must be considered as 'sheltered'
- 10) The use of stainless steel fixings is not recommended by steel manufacturers for use with coated steel in severe marine and industrial environments, as they are considered to cause deterioration.

Amend 5
Aug 2011

Amend 5
Aug 2011

Table 21: Compatibility of materials in contact

This table shall be read in conjunction with Table 20 and Table 22.
Refer relevant *cladding* and *flashings* paragraphs for material and coating specifications.
Paragraphs 2.2, 4.2.2, 4.5.2, 8.2.4, 8.4.11, 8.4.11.1 and 9.6.7

| | Aluminium, anodised or mill-finish | Aluminium, coated (1) | Butyl rubber & EPDM | CCA-treated timber (2) | Cedar | Cement plaster (uncoated) | Ceramic tiles (cement grout) | Clay bricks (cement mortar) | Concrete old (unpainted) | Concrete green (unpainted) | Copper/brass | Glass | Glazed roof tiles | Lead (including lead-edged) unpainted | Plastics | Stainless steel | Steel, galvanised coil-coated | Steel, galvanised (unpainted) | Zinc | Zinc/aluminium coated (1) | Zinc/aluminium, (unpainted) |
|---------------------------------------|------------------------------------|-----------------------|---------------------|------------------------|-------|---------------------------|------------------------------|-----------------------------|--------------------------|----------------------------|--------------|-------|-------------------|---------------------------------------|----------|-----------------|-------------------------------|-------------------------------|------|---------------------------|-----------------------------|
| Aluminium, anodised or mill-finish | ✓ | ✓ | ✓ | ✗ | ✓ | ✗ | ✗ | ✗ | ✓ | ✗ | ✗ | ✓ | ✓ | ✗ | ✓ | B | ✓ | ✓ | ✓ | ✓ | ✓ |
| Aluminium, coated (1) | ✓ | ✓ | ✓ | B | ✓ | ✗ | ✗ | ✗ | ✓ | ✗ | ✗ | ✓ | ✓ | B | ✓ | B | ✓ | ✓ | ✓ | ✓ | ✓ |
| Butyl rubber & EPDM | ✓ | ✓ | ✓ | ✓ | ✓ | ✓ | ✓ | ✓ | ✓ | ✓ | ✓ | ✓ | ✓ | ✓ | ✓ | ✓ | ✓ | ✓ | ✓ | ✓ | ✓ |
| CCA-treated timber (2) | ✗ | B | ✓ | ✓ | ✓ | ✓ | ✓ | ✓ | ✓ | ✓ | ✓ | ✓ | ✓ | ✓ | ✓ | ✓ | B | ✗ | ✗ | B | ✗ |
| Cedar | ✓ | ✓ | ✓ | ✓ | ✓ | ✓ | ✓ | ✓ | ✓ | ✓ | ✓ | ✓ | ✓ | ✓ | ✓ | ✓ | ✓ | ✗ | ✗ | ✓ | ✗ |
| Cement plaster (uncoated) | ✗ | ✗ | ✓ | ✓ | ✓ | ✓ | ✓ | ✓ | ✓ | ✓ | ✓ | ✓ | ✓ | ✗ | ✓ | ✓ | ✓ | ✓ | ✓ | ✓ | ✗ |
| Ceramic tiles (cement grout) | ✗ | ✗ | ✓ | ✓ | ✓ | ✓ | ✓ | ✓ | ✓ | ✓ | ✓ | ✓ | ✓ | ✓ | ✓ | ✓ | ✓ | ✓ | ✓ | ✓ | ✗ |
| Clay bricks (cement mortar) | ✗ | ✗ | ✓ | ✓ | ✓ | ✓ | ✓ | ✓ | ✓ | ✓ | ✓ | ✓ | ✓ | ✓ | ✓ | ✓ | ✓ | ✓ | ✓ | ✓ | ✗ |
| Concrete old (unpainted) | ✓ | ✓ | ✓ | ✓ | ✓ | ✓ | ✓ | ✓ | ✓ | ✓ | ✓ | ✓ | ✓ | ✓ | ✓ | ✓ | ✓ | ✓ | ✓ | ✓ | ✓ |
| Concrete green (unpainted) | ✗ | ✗ | ✓ | ✓ | ✓ | ✓ | ✓ | ✓ | ✓ | ✓ | ✓ | ✓ | ✓ | ✗ | ✓ | ✓ | ✗ | ✗ | ✗ | ✗ | ✗ |
| Copper/brass | ✗ | ✗ | ✓ | ✓ | ✓ | ✓ | ✓ | ✓ | ✓ | ✓ | ✓ | ✓ | ✓ | B | ✓ | B | ✗ | ✗ | ✗ | ✗ | ✗ |
| Glass | ✓ | ✓ | ✓ | ✓ | ✓ | ✓ | ✓ | ✓ | ✓ | ✓ | ✓ | ✓ | ✓ | ✓ | ✓ | ✓ | ✓ | ✓ | ✓ | ✓ | ✓ |
| Glazed roof tiles | ✓ | ✓ | ✓ | ✓ | ✓ | ✓ | ✓ | ✓ | ✓ | ✓ | ✓ | ✓ | ✓ | ✓ | ✓ | ✓ | ✓ | ✓ | ✓ | ✓ | ✓ |
| Lead (including lead-edged) unpainted | ✗ | B | ✓ | ✓ | ✓ | ✗ | ✓ | ✓ | ✓ | ✗ | B | ✓ | ✓ | ✓ | ✓ | B | B | B | B | B | ✗ |
| Plastics | ✓ | ✓ | ✓ | ✓ | ✓ | ✓ | ✓ | ✓ | ✓ | ✓ | ✓ | ✓ | ✓ | ✓ | ✓ | ✓ | ✓ | ✓ | ✓ | ✓ | ✓ |
| Stainless steel | B | B | ✓ | ✓ | ✓ | ✓ | ✓ | ✓ | ✓ | ✓ | B | ✓ | ✓ | B | ✓ | ✓ | B | ✗ | ✗ | B | B |
| Steel, galvanised coil-coated | ✓ | ✓ | ✓ | B | ✓ | ✓ | ✓ | ✓ | ✓ | ✗ | ✗ | ✓ | ✓ | B | ✓ | B | ✓ | ✓ | ✓ | ✓ | ✓ |
| Steel, galvanised (unpainted) | ✓ | ✓ | ✓ | ✗ | ✗ | ✓ | ✓ | ✓ | ✓ | ✗ | ✗ | ✓ | ✓ | B | ✓ | ✗ | ✓ | ✓ | ✓ | ✓ | ✓ |
| Zinc | ✓ | ✓ | ✓ | ✗ | ✗ | ✓ | ✓ | ✓ | ✓ | ✗ | ✗ | ✓ | ✓ | B | ✓ | ✗ | ✓ | ✓ | ✓ | ✓ | ✓ |
| Zinc/aluminium, coated (1) | ✓ | ✓ | ✓ | B | ✓ | ✓ | ✓ | ✓ | ✓ | ✗ | ✗ | ✓ | ✓ | B | ✓ | B | ✓ | ✓ | ✓ | ✓ | ✓ |
| Zinc/aluminium (unpainted) | ✓ | ✓ | ✓ | ✗ | ✗ | ✗ | ✗ | ✗ | ✓ | ✗ | ✗ | ✓ | ✓ | ✗ | ✓ | B | ✓ | ✓ | ✓ | ✓ | ✓ |

LEGEND:

- ✓ Materials satisfactory in contact.
- ✗ Contact between materials is not permitted. Minimum gap of 5 mm is required to prevent moisture bridging.
- B Avoid contact in sea-spray zone or corrosion zone D.

NOTES:

- (1) Coated – includes factory-painted, coil-coated and powder-coated.
- (2) Includes copper azole and copper quaternary salts.

Amend 2
Jul 2005

Amend 5
Aug 2011

Table 22: Compatibility of materials subject to run-off

This table shall be read in conjunction with Table 20 and Table 21.
Refer relevant *cladding* and *flashings* paragraphs for material and coating specifications.
Paragraphs 2.2, 4.2.2, 4.5.2, 8.2.4, 8.4.1 and 9.8.5

| Material that water flows onto | Material that water flows from | Aluminium, anodised or mill-finish | Aluminium, coated (1) | Butyl rubber & EPDM | CCA-treated timber (2) | Cedar | Cement plaster (uncoated) | Ceramic tiles (cement grout) | Clay bricks (cement mortar) | Concrete old (unpainted) | Concrete green (unpainted) | Copper/brass | Glass | Glazed roof tiles | Lead (including lead-edged) unpainted | Plastics | Stainless steel | Steel, galvanised coil-coated | Steel, galvanized (unpainted) | Zinc | Zinc/aluminium coated (1) | Zinc/aluminium, (unpainted) |
|---------------------------------------|--------------------------------|------------------------------------|-----------------------|---------------------|------------------------|-------|---------------------------|------------------------------|-----------------------------|--------------------------|----------------------------|--------------|-------|-------------------|---------------------------------------|----------|-----------------|-------------------------------|-------------------------------|------|---------------------------|-----------------------------|
| Aluminium, anodised or mill-finish | | ✓ | ✓ | ✓ | ✓ | ✓ | ✓ | ✓ | ✓ | ✓ | ✓ | ✓ | ✓ | ✓ | ✓ | ✓ | ✓ | ✓ | ✓ | ✓ | ✓ | ✓ |
| Aluminium, coated (1) | | ✓ | ✓ | ✓ | ✓ | ✓ | ✓ | ✓ | ✓ | ✓ | ✓ | ✓ | ✓ | ✓ | ✓ | ✓ | ✓ | ✓ | ✓ | ✓ | ✓ | ✓ |
| Butyl rubber & EPDM | | ✓ | ✓ | ✓ | ✓ | ✓ | ✓ | ✓ | ✓ | ✓ | ✓ | ✓ | ✓ | ✓ | ✓ | ✓ | ✓ | ✓ | ✓ | ✓ | ✓ | ✓ |
| CCA-treated timber (2) | | ✗ | ✗ | ✓ | ✓ | ✓ | ✓ | ✓ | ✓ | ✓ | ✓ | ✓ | ✓ | ✓ | ✓ | ✓ | ✓ | ✗ | ✗ | ✗ | ✗ | ✗ |
| Cedar | | ✓ | ✓ | ✓ | ✓ | ✓ | ✓ | ✓ | ✓ | ✓ | ✓ | ✓ | ✓ | ✓ | ✓ | ✓ | ✓ | ✓ | ✓ | ✓ | ✓ | ✓ |
| Cement plaster (uncoated) | | ✗ | ✗ | ✓ | ✓ | ✓ | ✓ | ✓ | ✓ | ✓ | ✓ | ✓ | A | ✓ | ✗ | ✓ | ✓ | ✓ | ✓ | ✓ | ✓ | ✓ |
| Ceramic tiles (cement grout) | | ✗ | ✗ | ✓ | ✓ | ✓ | ✓ | ✓ | ✓ | ✓ | ✓ | ✓ | A | ✓ | ✓ | ✓ | ✓ | ✓ | ✓ | ✓ | ✓ | ✓ |
| Clay bricks (cement mortar) | | ✗ | ✗ | ✓ | ✓ | ✓ | ✓ | ✓ | ✓ | ✓ | ✓ | ✓ | A | ✓ | ✓ | ✓ | ✓ | ✓ | ✓ | ✓ | ✓ | ✓ |
| Concrete old (unpainted) | | ✓ | ✓ | ✓ | ✓ | ✓ | ✓ | ✓ | ✓ | ✓ | ✓ | ✓ | A | ✓ | ✓ | ✓ | ✓ | ✓ | ✓ | ✓ | ✓ | ✓ |
| Concrete green (unpainted) | | ✗ | ✗ | ✓ | ✓ | ✓ | ✓ | ✓ | ✓ | ✓ | ✓ | ✓ | A | ✓ | ✗ | ✓ | ✓ | ✗ | ✗ | ✗ | ✗ | ✗ |
| Copper/brass | | ✗ | ✗ | ✓ | ✓ | ✓ | ✓ | ✓ | ✓ | ✓ | ✓ | ✓ | ✓ | ✓ | ✓ | ✓ | ✓ | ✗ | ✗ | ✗ | ✗ | ✗ |
| Glass | | ✓ | ✓ | ✓ | ✓ | ✓ | ✓ | ✓ | ✓ | ✓ | ✓ | ✓ | ✓ | ✓ | ✓ | ✓ | ✓ | ✓ | ✓ | ✓ | ✓ | ✓ |
| Glazed roof tiles | | ✓ | ✓ | ✓ | ✓ | ✓ | ✓ | ✓ | ✓ | ✓ | ✓ | ✓ | ✓ | ✓ | ✓ | ✓ | ✓ | ✓ | ✓ | ✓ | ✓ | ✓ |
| Lead (including lead-edged) unpainted | | ✗ | ✗ | ✓ | ✓ | ✓ | ✓ | ✓ | ✓ | ✓ | ✓ | ✓ | ✓ | ✓ | ✓ | ✓ | ✓ | ✓ | ✓ | ✓ | ✓ | ✓ |
| Plastics | | ✓ | ✓ | ✓ | ✓ | ✓ | ✓ | ✓ | ✓ | ✓ | ✓ | ✓ | ✓ | ✓ | ✓ | ✓ | ✓ | ✓ | ✓ | ✓ | ✓ | ✓ |
| Stainless steel | | ✓ | ✓ | ✓ | ✓ | ✓ | ✓ | ✓ | ✓ | ✓ | ✓ | ✓ | ✓ | ✓ | ✓ | ✓ | ✓ | ✓ | ✓ | ✓ | ✓ | ✓ |
| Steel, galvanised coil-coated | | ✓ | ✓ | ✓ | ✓ | ✓ | ✓ | ✓ | ✓ | ✓ | ✓ | ✓ | ✓ | ✓ | ✓ | ✓ | ✓ | ✓ | ✓ | ✓ | ✓ | ✓ |
| Steel, galvanized (unpainted) | | ✓ | ✓ | ✓ | ✓ | ✓ | ✓ | ✓ | ✓ | ✓ | ✓ | ✓ | ✓ | ✓ | ✓ | ✓ | ✓ | ✓ | ✓ | ✓ | ✓ | ✓ |
| Zinc | | ✓ | ✓ | ✓ | ✓ | ✓ | ✓ | ✓ | ✓ | ✓ | ✓ | ✓ | ✓ | ✓ | ✓ | ✓ | ✓ | ✓ | ✓ | ✓ | ✓ | ✓ |
| Zinc/aluminium, coated (1) | | ✓ | ✓ | ✓ | ✓ | ✓ | ✓ | ✓ | ✓ | ✓ | ✓ | ✓ | ✓ | ✓ | ✓ | ✓ | ✓ | ✓ | ✓ | ✓ | ✓ | ✓ |
| Zinc/aluminium (unpainted) | | ✓ | ✓ | ✓ | ✓ | ✓ | ✓ | ✓ | ✓ | ✓ | ✓ | ✓ | ✓ | ✓ | ✓ | ✓ | ✓ | ✓ | ✓ | ✓ | ✓ | ✓ |

LEGEND:

- ✓ Materials satisfactory with water run-off as indicated.
- ✗ Water run-off is not permitted as indicated.
- A Etching or staining of glass may occur with run-off.

NOTES:

- (1) Coated – includes factory-painted, coil-coated and powder-coated.
- (2) Includes copper azole and copper quaternary salts.

Amend 2
Jul 2005

Errata 2
Dec 2011**Table 23: Properties of roof underlays and wall underlays**

Paragraphs 6.2, 8.1.5, 8.2.3, 8.3.6, 8.4.7, 9.1.3.4, 9.1.4, 9.1.7.1, 9.1.7.2, 9.1.8.2, 9.2.4, 9.2.5, 9.3.3, 9.3.5.1, 9.4.2, 9.4.3, 9.5.3, 9.6.8.1, 9.6.9.1, 9.6.9.2, 9.7.2.1, 9.8.3 and 9.9.4

| Category | Application | Vapour resistance | Absorbency | Water resistance | pH of extract | Shrinkage | Mechanical |
|--|---|--|--|---|-----------------|-----------------|---|
| Roof (1) Underlay (Bitumen and fire-retardant paper-based products)(2) | All roofs | ≤ 7 MN s/g ASTM E96 B. | | | | | NZS 2295: 2006 section 3 |
| Flexible Wall Underlay (Includes paper and synthetic underlays) | <i>Wall claddings over a cavity</i> (6) Flexible <i>underlays over rigid underlays</i> – refer Paragraph 9.1.7.2 <i>Direct fixed absorbent wall claddings</i> (4) (eg, timber, fibre cement etc) <i>Direct fixed non-absorbent claddings</i> (3) | | | | | | NZS 2295: 2006 section 2 No minimum Absorbency requirement NZS 2295: 2006 section 2 Minimum Absorbency 100 g/m ² tested to NZS 2295 |
| Rigid Wall Underlay (plywood(5) and fibre cement sheet) | <i>Wall claddings over a cavity</i> (6) <i>Direct fixed absorbent wall claddings</i> (eg, timber, fibre cement etc) <i>Direct fixed non-absorbent claddings</i> (6) | ≤ 7 MN s/g ASTM E96 B. ≤ 7 MN s/g ASTM E96 B. | ≥ 100 g/m ² AS/NZS 4201: Part 6 | ≥ 20 mm NZS 2295 ≥ 20 mm AS/NZS 4201: part 4 | ≥ 6.0 and ≤ 9.0 | | |
| Air Barrier | Where no internal <i>linings</i> | ≤ 7 MN s/g ASTM E96 B. | ≥ 100 g/m ² (7) NZS 2295 | ≥ 20 mm NZS 2295 | ≥ 6.0 and ≤ 9.0 | ≤ 0.5% NZS 2295 | Edge tear strength NZS 2295 Air resistance BS 6538: Part 3: ≥ 0.1 MN s/m ³ |
| DPC/DPM | All applications | ≥ 90 MN s/g ASTM E96 | | | | | |

NOTE:

- 1) Metal roofs and *direct-fixed metal wall claddings* require paper-based underlays
- 2) Excluding synthetic underlays
- 3) Use paper based underlays where directly behind (in contact with) profiled metal wall cladding
- 4) Excludes profiled metal wall cladding
- 5) Plywood to be treated in accordance with NZS 3602
- 6) Bitumen based products shall not be used in direct contact with LOSP-treated plywood
- 7) Applies only to air barriers used with non-absorbent claddings.

Amend 5
Aug 2011Amends
2 and 5

Amend 5
Aug 2011

Table 24: Fixing selection for wall claddings
 Refer to NZS 3604 for fixing types where claddings act as structural bracing. Minimum fixing materials for non-structural claddings, shall be galvanised(1) steel for climate zones B,C and D (as outlined in NZS 3604). Where the cladding is a corrosive timber, such as western red cedar or redwood, or is treated with copper based ACQ or CuAz preservatives, use stainless steel(2)
COMMENT: Some manufacturers may require more durable fixings than those stated below or in NZS 3604 to maintain product warranties.
 Paragraphs 9.4.4.3, 9.4.5.2, 9.5.3.1, 9.7.2.1, 9.8.3.1, 9.9.4.1, Table 18B

| Joint | Length (mm) x diameter (mm) and type | Minimum framing penetration | Fixing pattern | Requirements |
|---|--------------------------------------|-----------------------------|---|--|
| Cavity battens | | | | |
| Battens to <i>framing</i> | NA | NA | NA | Battens will be fixed by the <i>cladding</i> fixings, which will penetrate the wall <i>framing</i> . Battens will therefore need only temporary fixing until the <i>cladding</i> is fixed. |
| Stucco plaster | | | | |
| Rigid backing to <i>framing</i> | 60 x 2.5 FH nail | 35 mm | 150 mm centres to sides and 300 mm centres in middle | |
| Metal lath to <i>framing</i> | 40 x 2.5 FH nail or 40 x 2.8 FH nail | 35 mm | 150 mm centres | |
| Fibre cement weatherboards | | | | |
| Weatherboard DIRECT FIXED | 50 x 2.8 fibre cement nail | 35 mm | Single fixing 20 mm above lower board, through both thicknesses | |
| Weatherboard OVER CAVITY | 75 x 3.15 fibre cement nail | 35 mm | as above | |
| Timber weatherboards: paint finish DIRECT FIXED | | | | |
| Horizontal bevel-back | 75 x 3.15 JH nail | 35 mm | Single fixing 10 mm above top of lower board | |
| Horizontal rebated bevel-back | 60 x 2.8 JH nail | 35 mm | as above | |
| Horizontal rusticated | 60 x 2.8 JH nail | 35 mm | as above | |
| Vertical shiplap | 60 x 2.8 JH nail | 35 mm | Single fixing 10 mm from side lap (40 mm from edge of board) | <i>Dwangs</i> at maximum 480 mm centres. |
| Board and batten: board | 60 x 2.8 JH nail | 35 mm | Single fixing in centre or nails clenched over each side | as above |
| Board and batten: batten | 75 x 3.15 JH nail | 35 mm | Single fixing in centre of batten | as above |
| Timber weatherboards: paint finish OVER CAVITY | | | | |
| Horizontal bevel-back | 90 x 4.0 JH nail | 35 mm | Single fixing 10 mm above top of lower board | |
| | 75 x 3.15 annular grooved nail | 25 mm | Single fixing 10 mm above top of lower board | |
| Horizontal rebated bevel-back | 75 x 3.15 JH nail | 35 mm | as above | |
| LEGEND: | | | | |
| RH rose head | JH jolt head | FH flat head | | |
| NOTE: Nail lengths are designed for minimum penetration of <i>framing</i> . If thickness of the batten or <i>cladding</i> is varied, length shall be adjusted accordingly. | | | | |

Amend 5
Aug 2011

Amend 2
Jul 2005

Table 24: Fixing selection for wall claddings (*continued*)

| Joint | Length (mm) x diameter (mm) and type | Minimum framing penetration | Fixing pattern | Requirements |
|--|--------------------------------------|-----------------------------|--|---|
| Horizontal rusticated | 75 x 3.15 JH nail | 35 mm | Single fixing 10 mm above top of lower board | |
| Timber weatherboards: stained or bare finish | | | | |
| DIRECT FIXED | | | | |
| Horizontal bevel-back | 65 x 3.2 RH annular grooved nail | 30 mm | Single fixing 10 mm above top of lower board | |
| Horizontal rebated bevel-back | 50 x 3.2 RH annular grooved nail | 30 mm | as above | |
| Horizontal rusticated | 50 x 3.2 RH annular grooved nail | 30 mm | as above | |
| Vertical shiplap | 50 x 3.2 RH annular grooved nail | 30 mm | Single fixing 10 mm from side lap (40 mm from edge of board) | <i>Dwangs</i> at maximum 480 mm centres |
| Board and batten: board | 60 x 3.2 RH annular grooved nail | 30 mm | Single fixing in centre of board | as above |
| Board and batten: batten | 75 x 3.2 RH annular grooved nail | 30 mm | as above | as above |
| Timber weatherboards: stained or bare finish | | | | |
| OVER CAVITY | | | | |
| Horizontal bevel-back | 85 x 3.2 RH annular grooved nail | 30 mm | Single fixing 10 mm above top of lower board | |
| Horizontal rebated bevel-back | 70 x 3.2 RH annular grooved nail | 30 mm | as above | |
| Horizontal rusticated | 70 x 3.2 RH annular grooved nail | 30 mm | as above | |
| Vertical profiled metal: DIRECT FIXED | | | | Refer Paragraph 9.6.6 |
| Horizontal profiled metal: OVER CAVITY | | | | Refer Paragraph 9.6.6 |
| Plywood sheet: paint finish DIRECT FIXED | | | | |
| Plywood to stud or batten | 50 x 2.8 FH nail | 30 mm | 150 mm centres to sides, 300 mm centres in middle | |
| External cover batten | 65 x 3.2 RH annular grooved nail | 30 mm | 300 mm centres in centre of batten | |
| Plywood sheet: paint finish OVER CAVITY | | | | |
| Plywood | 60 x 2.8 FH nail | 30 mm | 150 mm centres to sides, 300 mm centres in middle | |
| Cover batten | 60 x 2.8 JH nail | To cavity battens only | 300 mm centres in centre of batten | |
| Plywood sheet: stained or bare finish DIRECT FIXED | | | | |
| Plywood to stud or batten | 50 x 2.8 FH nail | 30 mm | 150 mm centres to sides, 300 mm centres in middle | |
| External cover batten | 65 x 3.2 RH annular grooved nail | 30 mm | 300 mm centres in centre of batten | |
| LEGEND: | | | | |
| RH rose head | JH jolt head | FH flat head | | |
| NOTE: Nail lengths are designed for minimum penetration of <i>framing</i> . If thickness of the batten or <i>cladding</i> or <i>underlay</i> is varied, length shall be adjusted accordingly. | | | | |

Amend 5
Aug 2011Amend 2
Jul 2005Amend 5
Aug 2011Amend 2
Jul 2005Amend 5
Aug 2011

| Table 24: Fixing selection for wall claddings (continued) | | | | |
|---|---|------------------------------------|--|---------------------|
| Joint | Length (mm) x diameter (mm) and type | Minimum framing penetration | Fixing pattern | Requirements |
| Plywood sheet: stained or bare finish OVER CAVITY | | | | |
| Amend 5 Aug 2011 Plywood | 65 x 3.2 FH nail | 30 mm | 150 mm centres to sides, 300 mm centres in middle | |
| External cover batten | 65 x 3.2 RH annular grooved nail | To cavity battens only | 300 mm centres in centre of batten | |
| Amend 5 Aug 2011 | Fibre cement sheet: jointed DIRECT FIXED | | | |
| Amend 2 Jul 2005 Sheet | 40 x 2.8 fibre cement nail | 30 mm | 150 mm centres to sides, 300 mm centres in middle | |
| External cover batten | 65 x 3.15 JH nail | 30 mm | Single fixing in centre of batten | |
| Amend 5 Aug 2011 | Fibre cement sheet: jointed OVER CAVITY | | | |
| Amend 2 Jul 2005 Sheet | 60 x 3.15 fibre cement nail | 30 mm | 150 mm centres to sides, 300 mm centres in middle | |
| External cover batten | 65 x 3.15 JH nail | To cavity battens only | Single fixing in centre of batten | |
| Amend 2 Jul 2005 | Fibre cement sheet: flush-finish | | | |
| OVER CAVITY | 60 x 3.15 fibre cement nail | | as above | |
| EIFS | | | | |
| 40 mm polystyrene sheet OVER CAVITY | 90 x 4.0 nail | 30 mm | as above and with 40 mm plastic washers on external corner fixings | |
| LEGEND: RH rose head JH jolt head FH flat head | | | | |
| NOTE: 1. Galvanised nails shall be hot-dipped galvanised; galvanised screws shall be mechanically zinc plated in accordance with AS 3566 Class 4. 2. Stainless steel nails shall have annular grooves to provide similar withdrawal resistance to hot-dip galvanised nails. | | | | |

Amend 5
Aug 2011

Amend 5
Aug 2011

ARCHIVED

Acceptable Solution E2/AS2

1.0 Earth buildings

Earth buildings complying with NZS 4299 as modified by this Acceptable Solution meet the performance criteria of NZBC E2.

Where *buildings* are based on NZS 4299 but require specific structural engineering design input, the structure must be of at least equivalent stiffness to the provisions of NZS 4299. Such designs are outside the scope of this Acceptable Solution and proposals must be submitted to, and approved by, the building consent authority as part of the normal building consent process.

1.1 Modifications to NZS 4299

Clause 2.1.8.5 Add new Clause:

2.1.8.5

Install a damp proof course (DPC) to separate timber from concrete, cement stabilised earth and lime stabilised earth. DPC material must be bituminous paint or sheet material as specified in Clause 4.9.1.

Figure 4.1 Replace Figure 4.1 with:

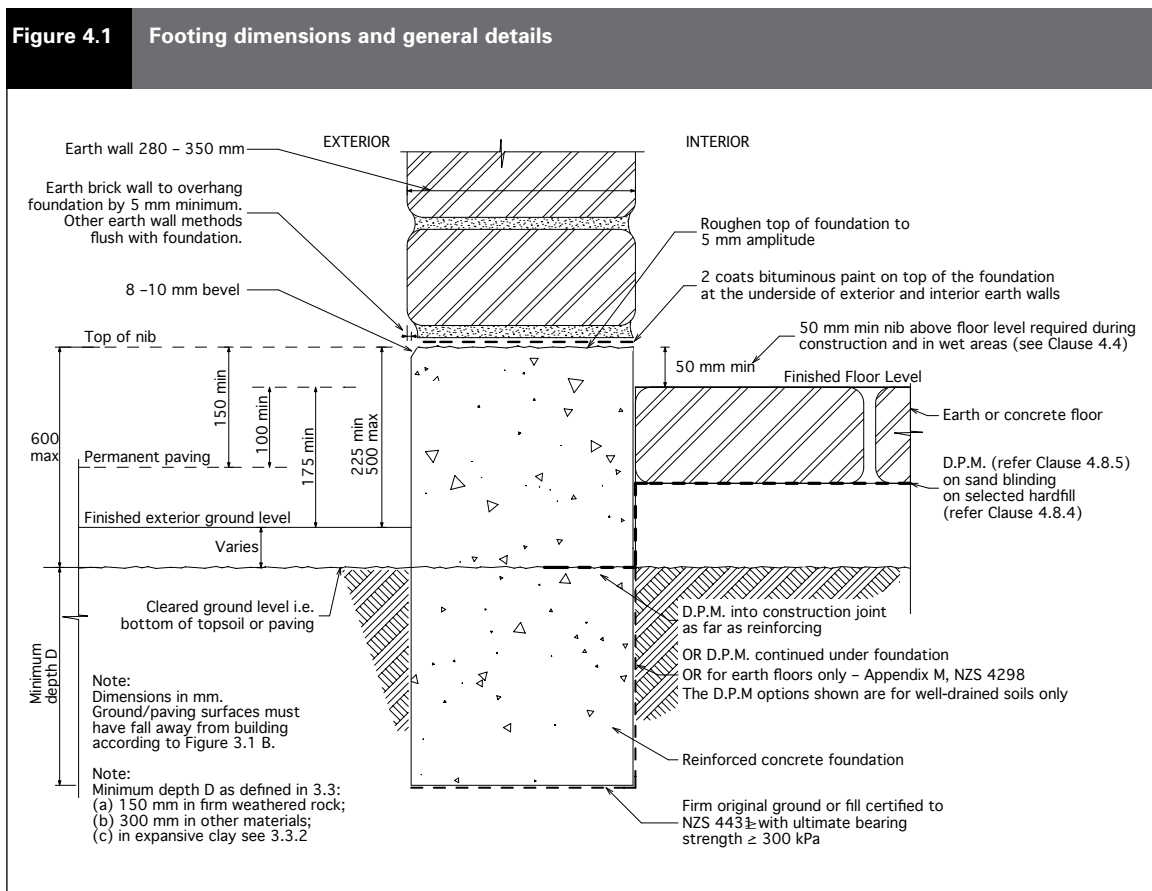

Clause 5.1.8 Add new Clause:

5.1.8

The external surface of earth walls must be finished in accordance with Clauses 2.2.3.5, 2.2.4.2 and 2.2.4.3 of NZS 4298. The external surface of earth walls must be free from features, such as horizontal protrusions, that could cause water to become trapped or directed towards the inside of the building.

C5.1.8

Water must be able to flow downwards and off the external surface of earth walls.

External earth wall surfaces are not required to have a surface coating to meet this Acceptable Solution.

The use of surface coatings does not replace or diminish the need for eaves as required by Clause 2.10.

Clause 5.12 Add new Clause and Figure:

5.12 Soffit to wall junction

The junction between the soffit and the earth wall must be constructed as shown in Figure 5.11.

Figure 5.11 Soffit to wall junction
A) Flat soffit

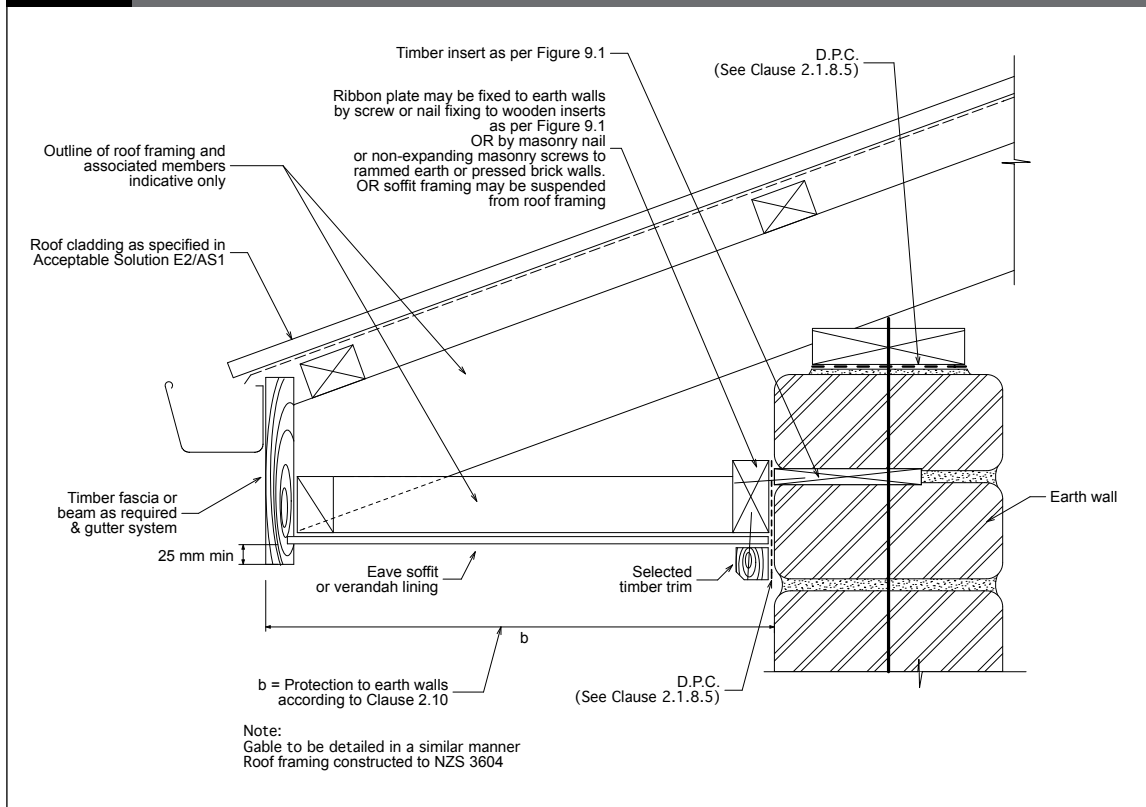

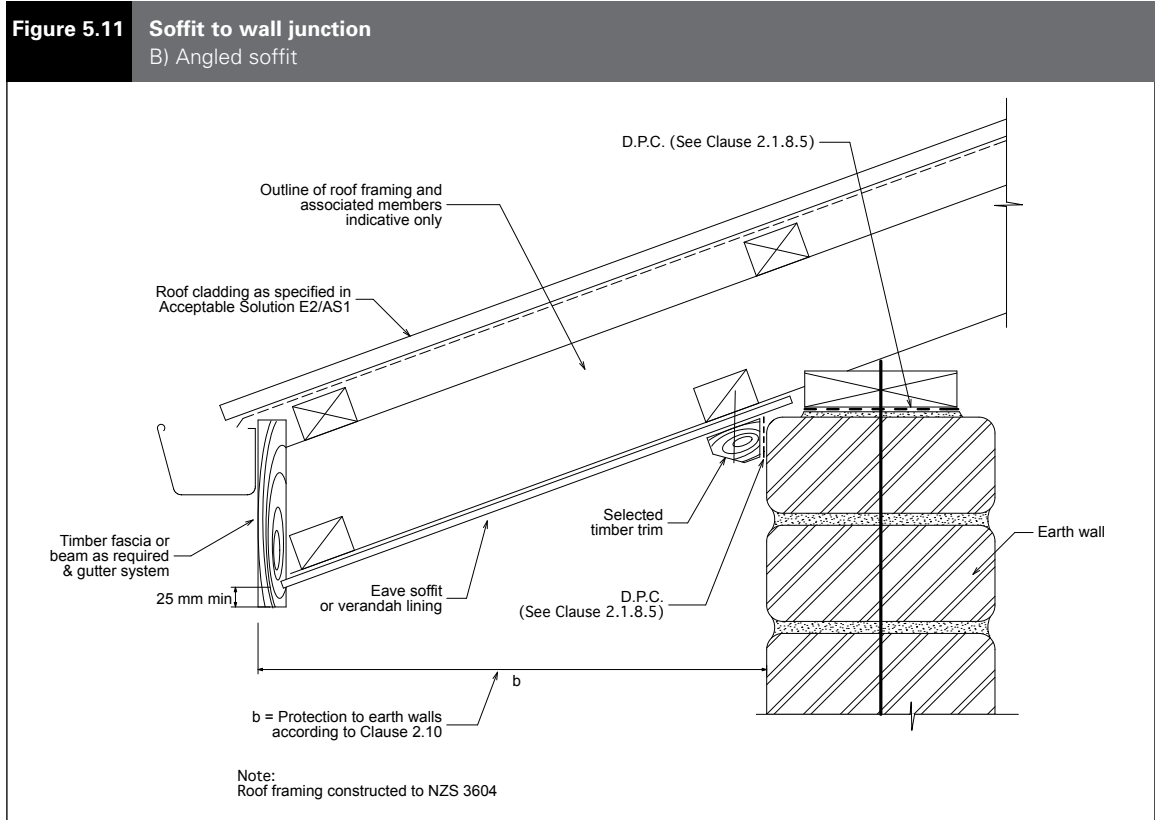

Clause 5.13 Add new Clause and Figure:

5.13 Timber-framed gable wall

The junction between timber-framed gable walls and earth walls must be constructed as shown in Figure 5.12.

Figure 5.12 Timber-framed gable to earth wall

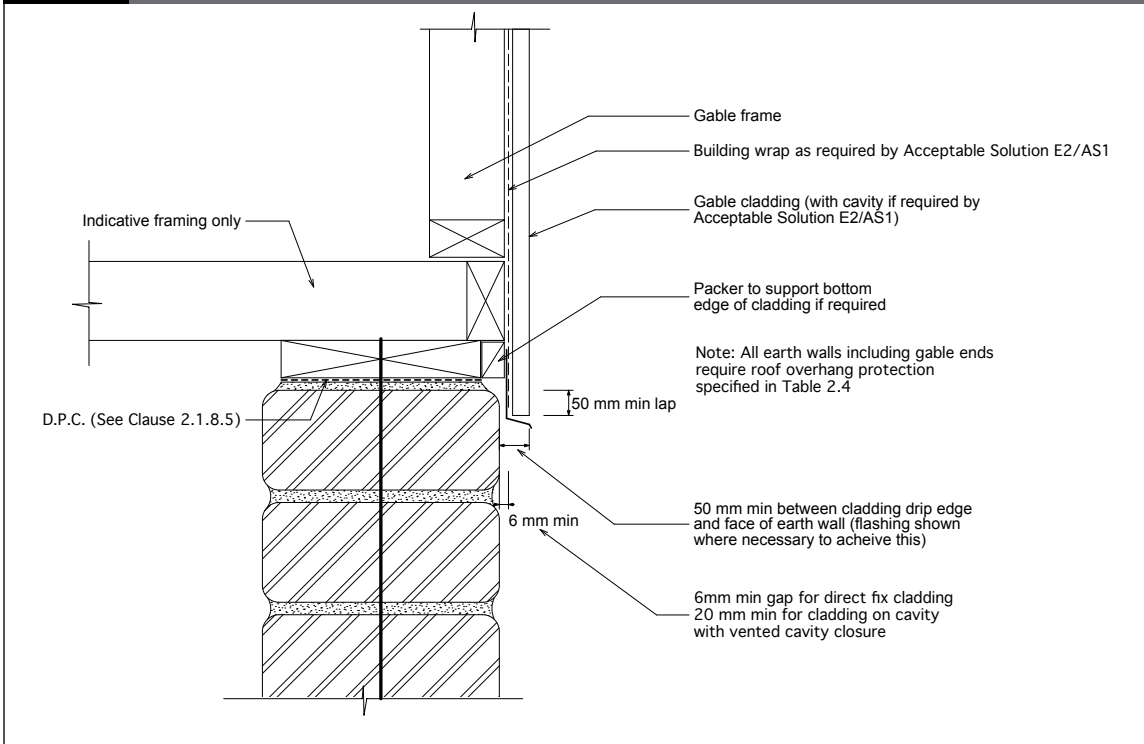

Clause 9.2 Add the following new paragraph to end of Clause 9.2:

“Windows and doors with arched or sloping heads are outside the scope of this Standard”.

Clause C9.2 Add the following new paragraph to end of commentary Clause C9.2:

Amend 5
Aug 2011

COMMENT:

Requirements for window and door joinery are not included in this Acceptable Solution. For more information, designers may refer to:

- NZS 3504: 1979 *Specification for aluminium windows*
- NZS 3610: 1979 *Specification for profiles of mouldings and joinery*
- NZS 3619: 1979 *Specification for timber windows.*

Figure 9.2 Replace Figure 9.2 with:

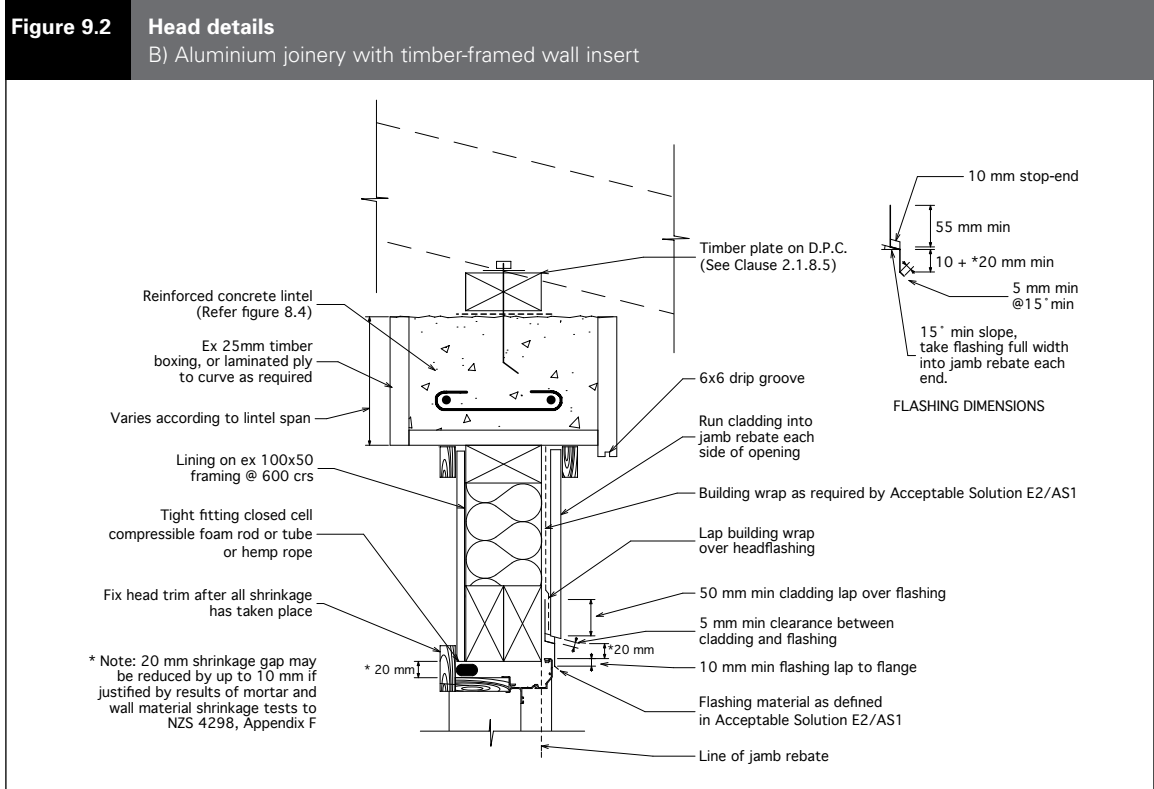
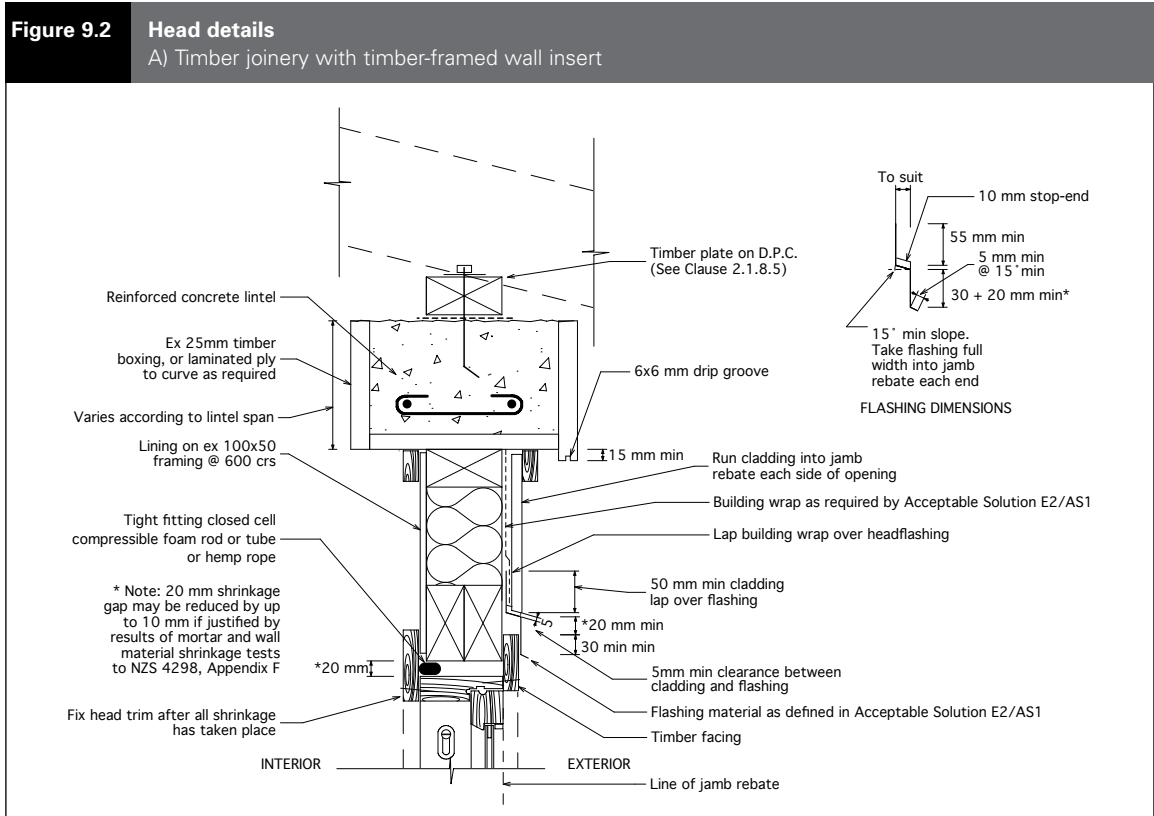

Figure 9.2 Head details
C) Timber joinery with timber lintel

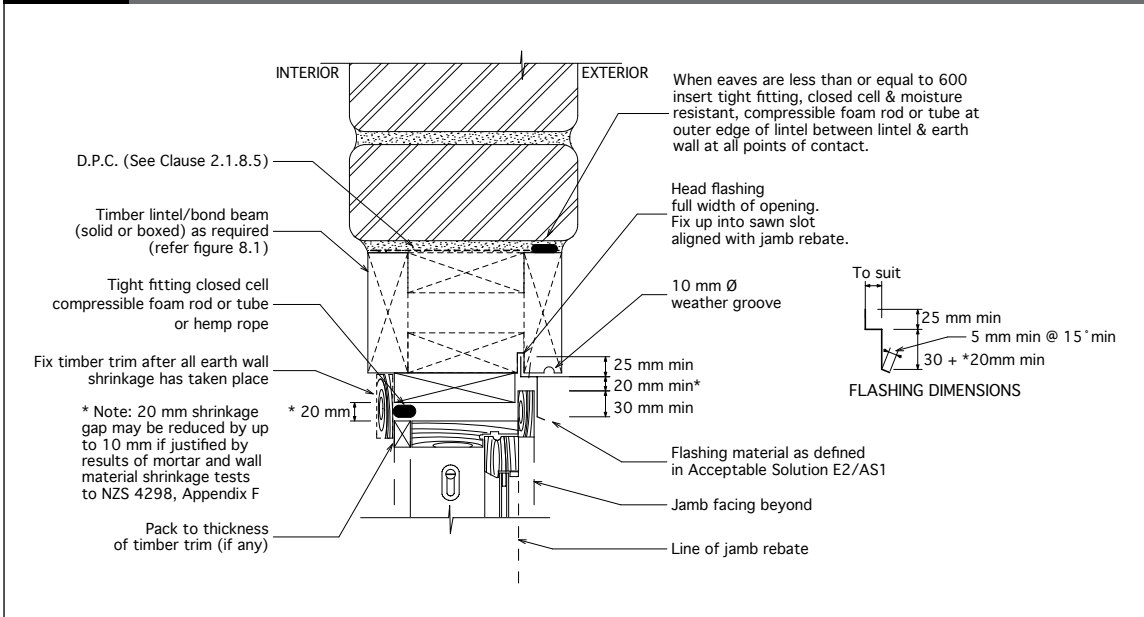

Figure 9.2 Head details
D) Aluminium joinery with timber lintel

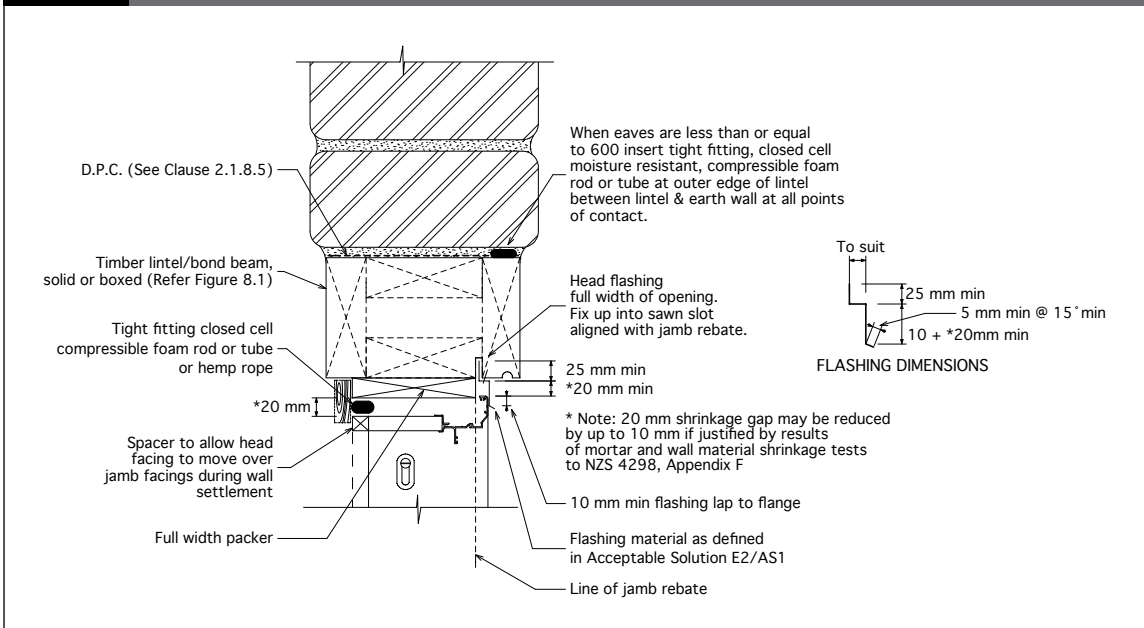

Figure 9.3 Replace Figure 9.3 with:

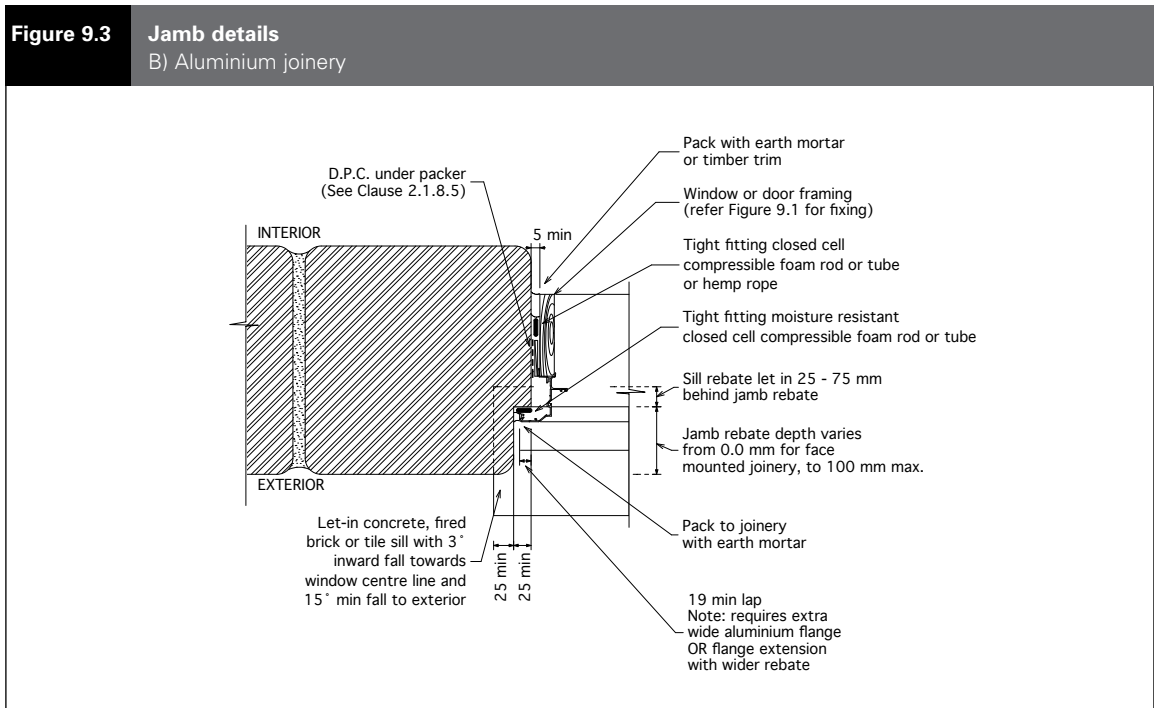
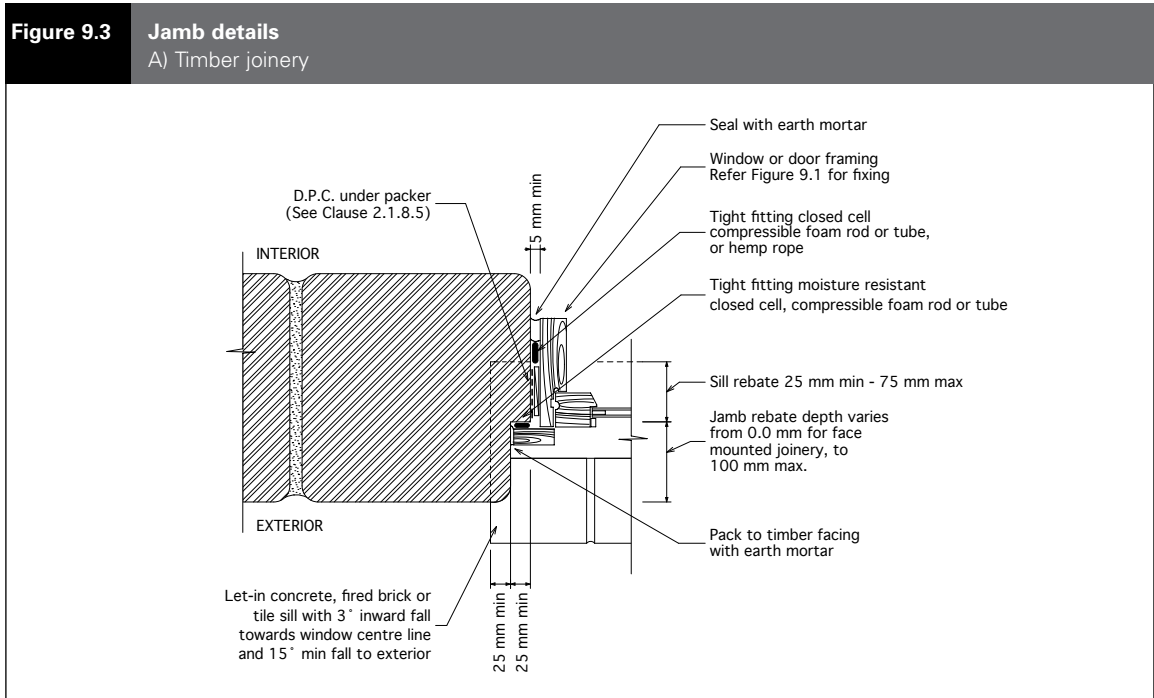

Figure 9.4 Replace Figure 9.4 with:

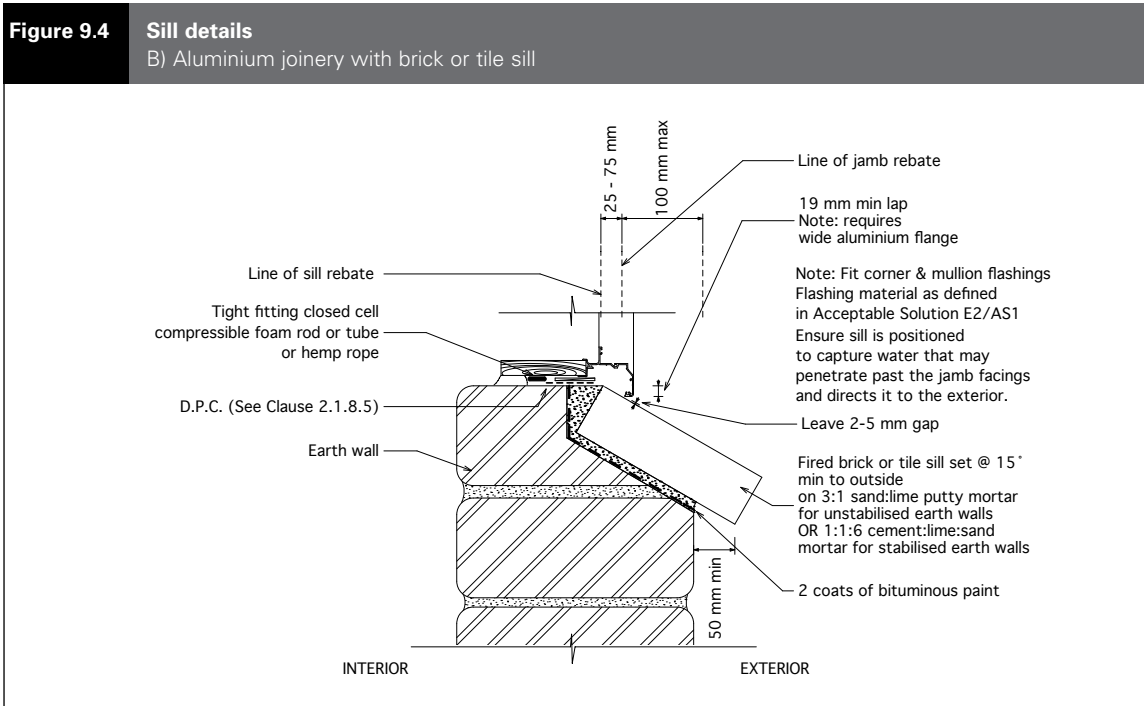
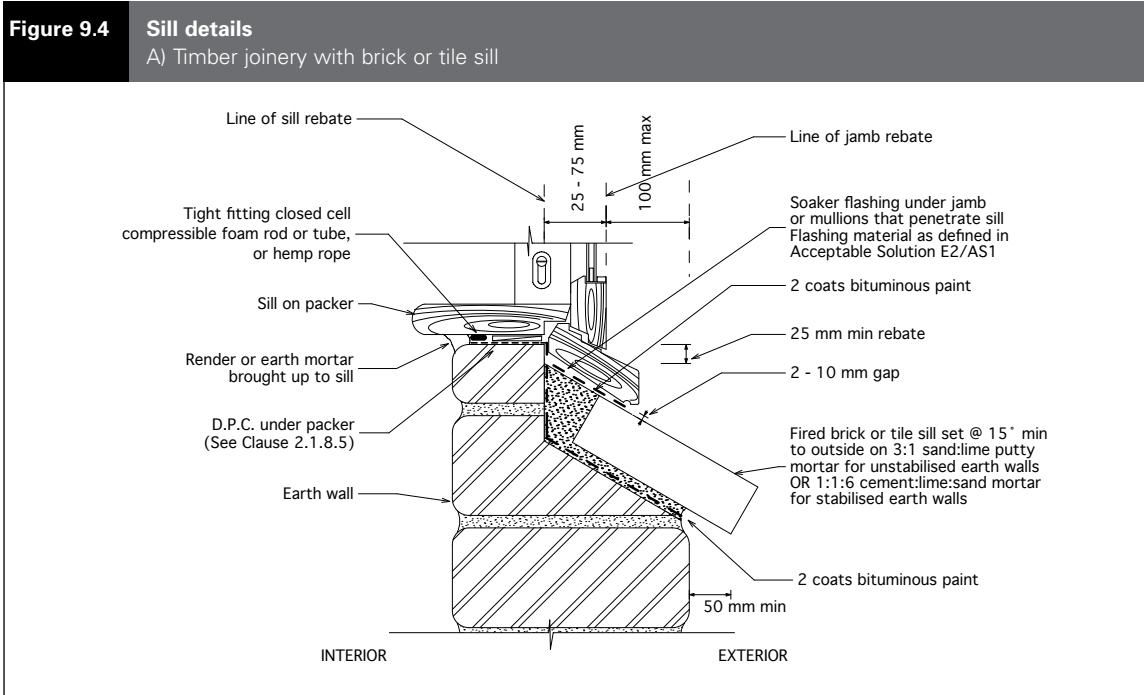

Figure 9.4 Sill details
C) Timber joinery with concrete sill

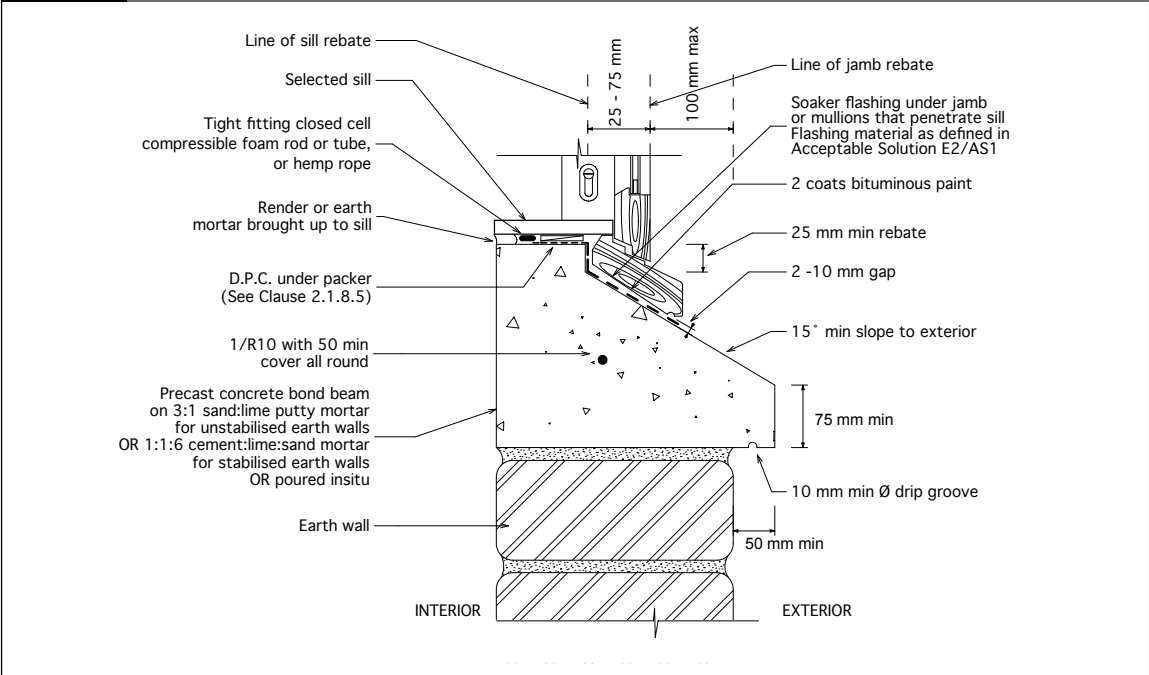
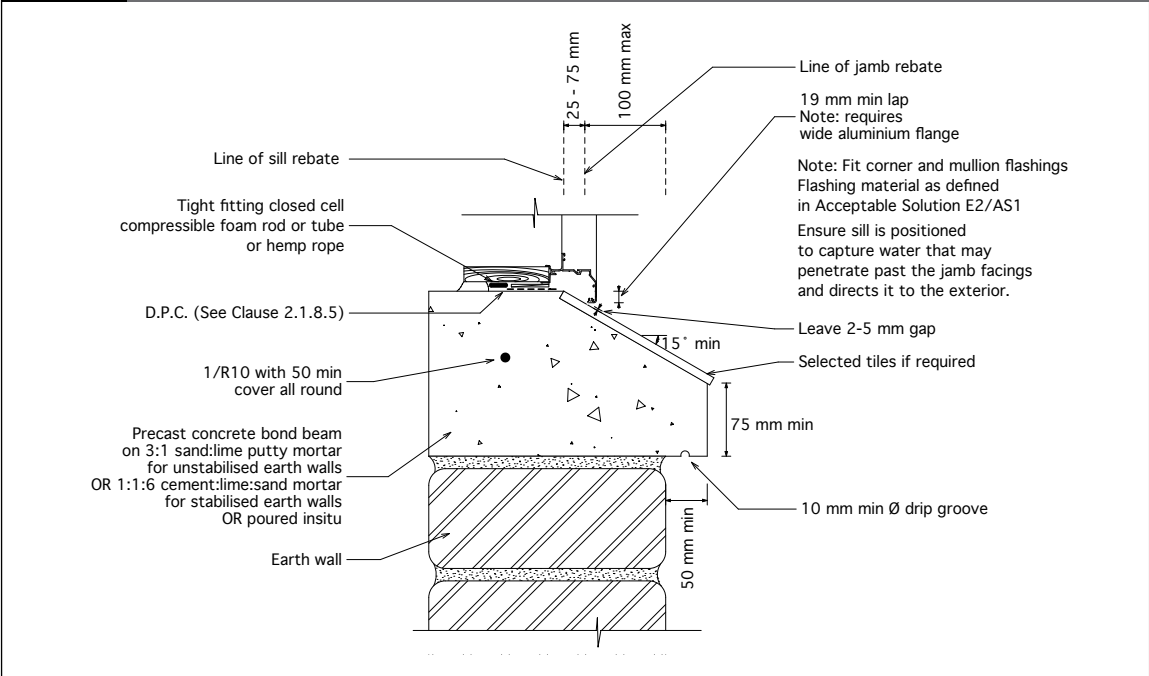

Figure 9.4 Sill details
D) Aluminium joinery with concrete sill



Clause 9.7 Add new Clause:

9.7 Penetrations

9.7.1

The upper surface of elements (e.g. pipes and meterboxes) that penetrate external walls must be sloped downwards to the exterior to direct moisture away from the wall and to discharge it clear of the wall surface.

COMMENT:

C9.7.1

Penetrations should be located where they are sheltered from wind-driven rain – this may be achieved by positioning the penetration in a sheltered location or as high as practical under eaves on the wall.

9.7.2

Penetrations less than 200mm wide must meet the requirements of NZS 4298 Clause 2.1.12 and must be sealed all round with a tight-fitting moisture resistant compressible closed cell foam rod or tube that is finished 25 mm behind the wall surface, with the resulting gap filled with:

- i) for unstabilised earth construction, a compatible unstabilised mortar
- ii) for stabilised earth construction, a compatible stabilised mortar.

COMMENT:

C9.7.2

Generally sealants do not adhere well to earthen surfaces with the possible exception of dense stabilised rammed earth or pressed earth brick.

9.7.3

Penetrations more than 200mm wide (e.g. meterboxes) must be anchored as required in Clause 9.1 and must meet the following requirements:

- a) Where the depth of the penetration is more than 1/3 of the wall depth, the penetration must incorporate head, jamb and sill details similar to those required for windows.
- b) Where the depth of the penetration is less than 1/3 of the wall depth, the penetration must be sealed all round with a compatible mortar as required by Clause 9.7.2.

Amend 5
Aug 2011

Amend 5
Aug 2011

Acceptable Solution E2/AS3

1.0 Concrete and Concrete Masonry Buildings

Concrete and concrete masonry construction with the scope of CCANZ CP 01, and that complies with CCANZ CP 01, will meet the performance criteria of NZBC E2.

Errata 2
Dec 2011
Amend 5
Aug 2011

ARCHIVED

Index E2/VM1 & AS1/AS2/AS3

**Pages 193–204 INDEX deleted
by Amendment 5**

ARCHIVED