

GUIDANCE

Assessment, repair and rebuild of earthquake-affected industrial buildings in Canterbury



ISBN: 978-0-478-43347-0 (Online)

ISBN: 978-0-478-43348-7 (Print)

Published December 2014

Infrastructure and Resource Markets

Ministry of Business Innovation & Employment (MBIE)

PO Box 1473, Wellington 6140, New Zealand

www.mbie.govt.nz

New Zealand Government

CROWN COPYRIGHT © 2015



This work is licensed under the Creative Commons Attribution 3.0 New Zealand licence. In essence, you are free to copy, distribute and adapt the work, as long as you attribute the work to the Crown and abide by the other licence terms. To view a copy of this licence, visit www.creativecommons.org/licenses/by/3.0/nz. Please note that no departmental or governmental emblem, logo or Coat of Arms may be used in any way which infringes any provision of the Flags, Emblems, and Names Protection Act 1981. Attribution to the Crown should be in written form and not by reproduction of any such emblem, logo or Coat of Arms.

Assessment, repair and rebuild of earthquake-affected industrial buildings in Canterbury

This document's status

Important note:

It is recommended that, when carrying out evaluations and reviews using this guidance, the responsibilities and liabilities that may be involved are recognised.

This document is guidance only and application may be different depending on the facts of a particular building. However, the guidance should provide a basis for structural and geotechnical engineers to undertake a more detailed evaluation of earthquake-affected industrial buildings.

This document is issued as guidance under section 175 of the Building Act 2004 (the Building Act). While the Ministry of Business, Innovation and Employment (the Ministry) has taken care in preparing the document, it is only a guide and, if used, does not relieve any person of the obligation to consider any matter to which that information relates according to the circumstances of the particular case. The document may be updated from time to time and the latest version is available from the Ministry's website at www.dbh.govt.nz.

This guidance is a standalone document, however for further information readers are referred to the following documents:

- › Guidance on Detailed Engineering Evaluation of Earthquake Affected Non-residential Buildings in Canterbury (draft prepared by the MBIE Engineering Advisory Group), available at www.sesoc.org.nz
- › Assessment and Improvement of the Structural Performance of Buildings in Earthquakes (prepared by the New Zealand Society for Earthquake Engineering Inc.), available at www.nzsee.org.nz

Audience

This guidance is intended for structural and geotechnical engineers and local authorities in the assessment and repair of earthquake-affected industrial buildings in Canterbury.

Foreword

This document, issued by the Ministry, provides technical and regulatory guidance for the assessment, repair and rebuild of industrial buildings in Canterbury, which were affected by the Canterbury earthquake sequence.

Christchurch has a substantial manufacturing and distribution industry sector. The imperatives for these businesses to keep running or return to work quickly are not only part of the overall need to get back to normal, but are also driven by the financial pressures of return-on-investment and maintenance of a skilled workforce. The resilience evident in this sector needs the support of building professionals to facilitate minimum disruption and cost-effective repair and rebuild within the building control framework prescribed by the Building Act. This document is targeting the engineering approach to this recovery.

The underlying purpose of this document is to assist owners, occupiers and their advisors to navigate the technical issues within the regulatory context. Its primary objective is to provide guidance on the appropriate criteria for continued use of buildings, particularly those on land prone to liquefaction.

The document is guidance and is therefore not mandatory. It aims to address perceived regulatory barriers in undertaking repairs to industrial buildings and provides robust and pragmatic solutions developed using the collective expertise of the Ministry's Engineering Advisory Group (Commercial), with input from a wider group of practitioners, from owners to advisors. By describing a process that is transparent and readily communicated, it is intended that the guidance will aid informed decision making.

The general philosophies and approaches in this guidance may be applied to a wider range of non-residential/low rise buildings.

Adrian Regnault

General Manager, Building System Performance
Ministry of Business, Innovation, and Employment

Mike Stannard

Chief Engineer
Ministry of Business, Innovation, and Employment

Acknowledgements

In preparing this document, the Ministry acknowledges and is grateful for the contributions from the Ministry's Engineering Advisory Group (Commercial), consisting of:

Name	Organisation
Barry Brown	Fraser Thomas Ltd
Dave Brunsdon	Kestrel Group Ltd
Des Bull	Holmes Consulting Group
Graeme Beattie	BRANZ Ltd
Ian McCahon	Geotech Consulting Ltd
John Hare	Holmes Consulting Group
Kevin McManus	McManus Geotech Ltd
Mike Stannard	Ministry of Business, Innovation & Employment
Nick Traylen	Geotech Consulting Ltd
Peter Millar	Tonkin & Taylor Ltd
Peter Smith	Spencer Holmes Ltd
Rob Jury	Beca Ltd

Contents

1. Introduction	1.1
1.1 Background	1.1
1.2 Scope.....	1.1
1.3 Guiding principles	1.2
1.4 Building construction types	1.2
1.5 Context	1.3
1.6 Building ownership.....	1.4
1.7 Building purpose.....	1.4
2. Performance expectations	2.1
2.1 Regulatory requirements.....	2.1
2.1.1 Regulatory considerations	2.1
2.1.2 Building regulatory framework.....	2.2
2.1.3 Building Code structural requirements - Clause B1.....	2.3
2.1.4 Rupture and instability (NZBC B1.3.1).....	2.4
2.1.5 Loss of amenity (NZBC B1.3.2)	2.4
2.1.6 Repairability.....	2.5
2.2 Liquefaction.....	2.6
2.3 Special legal issues	2.6
2.3.1 Safety in carrying out work.....	2.6
2.3.2 Seismic risk management and health and safety concerns	2.7
2.3.3 Flood risk and floor levels	2.9
3. Assessment	3.1
3.1 Recommended assessment approach.....	3.1
3.1.1 Observation	3.2
3.1.2 Site hazards	3.3
3.1.3 Vulnerability.....	3.3
3.1.4 Consequence	3.3
3.1.5 Amenity (use of the facility)	3.3
3.1.6 Repair or rebuild strategies.....	3.4

3.2	Geotechnical considerations	3.4
3.2.1	Ground performance	3.4
3.2.2	Building response to liquefaction	3.5
3.2.3	Lateral spread	3.7
3.2.4	Geotechnical investigation	3.7
3.2.5	Investigation parameters and methodology	3.10
3.3	Structural considerations	3.11
3.3.1	Primary structure	3.11
3.3.2	Differential settlement effects	3.12
3.3.3	Roof bracing	3.14
3.3.4	Out-of-plane failures	3.15
3.3.5	Assessing connections	3.16
3.3.6	Configuration issues	3.19
3.3.8	Fire considerations	3.22
3.3.9	Inter-tenancy (party) walls	3.22
3.3.10	Underground tanks and basements	3.22
3.4	Detailed assessment approach	3.23
3.4.1	Overview	3.23
3.4.2	Structural assessment	3.24
3.5	Example using assessment criteria	3.32
4.	Repairs	4.1
4.1	General	4.1
4.2	Regulatory requirements	4.2
4.2.1	Net Structural Benefit Test	4.3
4.2.2	Disabled access and fire provisions	4.3
4.2.3	Units across multiple titles	4.5
4.2.4	Party walls	4.5
4.2.5	Detailed Engineering Evaluation	4.6
4.3	Structural repairs using comparable limited replacement	4.6
4.3.1	Criteria applicable to comparable replacement	4.6
4.3.2	Remedial work where foundation settlement has contributed to damage	4.7
4.3.3	Remedial work where damage is due to excessive earthquake response	4.8
4.3.4	Compliance	4.9

4.4 Major structural repairs.....	4.10
4.4.1 Foundation performance.....	4.10
4.4.2 Superstructure performance.....	4.10
4.4.3 Compliance	4.11
4.5 Building element repair.....	4.11
4.5.1 Foundations.....	4.11
4.5.2 Releveling.....	4.12
4.5.3 Primary lateral load resisting systems.....	4.12
4.5.4 Secondary elements	4.16
4.5.5 Repairing connections.....	4.17
4.6 Common structural issues and options	4.20

5. Rebuilds in liquefaction-prone areas **5.1**

5.1 Introduction.....	5.1
5.2 Regulatory requirements.....	5.1
5.2.1 Building Code requirements	5.1
5.3 Recommended approach	5.2
5.3.1 Site considerations.....	5.2
5.3.2 General design concepts.....	5.2
5.3.3 Design decision consequences	5.3
5.4 Demonstrating compliance.....	5.4
5.4.1 Building Act.....	5.4
5.4.2 Building Code.....	5.4
5.4.3 Other considerations	5.4
5.4.4 Compliance.....	5.5
5.4.5 Foundations.....	5.5
5.4.6 Concrete floors.....	5.7
5.4.7 Primary structure	5.8
5.4.8 Secondary structural elements	5.8

Appendix A: Building vulnerabilities **A.1**

A.1 Key points.....	A.1
A.1.1 Structural assessment	A.1
A.1.2 Objective	A.1
A.1.3 Liquefaction.....	A.1
A.1.4 Connection details.....	A.2
A.1.5 Representative details.....	A.2

A.2	Sample list of typical vulnerabilities for industrial buildings	A.3
A.2.1	Floor or ceiling joist/wall connection	A.3
A.2.2	Floor joist/perimeter beam connection	A.4
A.2.3	Precast floor (eg hollow core slab seating)	A.5
A.2.4	Precast wall panel 'pull in' by secondary roof steelwork	A.6
A.2.5	Steel weld plate connecting horizontally spanning wall panels to steel portal frame.....	A.7
A.2.6	Precast lintel panel over doorway supported by weld plates and subject to differential settlement of supports	A.8

Appendix B: Tolerable impacts for reduced amenity **B.1**

Appendix C: Low-rise panel structures **C.1**

C.1	Acknowledgement.....	C.1
C.2	Introduction.....	C.1
C.3	Seismic response characteristics and common deficiencies	C.1
C.3.1	Precast panel system behaviour	C.1
C.3.2	Base connections	C.2
C.3.3	Vertical joints between panels.....	C.2
C.3.4	Foundation compliance	C.2
C.4	Single storey commercial applications	C.4
C.4.1	Reinforcement	C.4
C.4.2	Connections.....	C.4
C.4.3	Foundations.....	C.4
C.4.4	Out-of-plane support	C.4
C.4.5	Stiffness compatibility.....	C.4
C.5	Failure mode and repair assessment	C.5
C.5.1	In-plane and out-of-plane loading	C.5
C.6	Reporting results.....	C.8

Appendix D: Definitions **D.1**

Figures

Figure 2.1:	Building capacity through earthquakes	2.7
Figure 3.1:	General assessment approach	3.1
Figure 3.2:	Settlement patterns.....	3.6
Figure 3.3:	Soil and damage investigation selection criteria for liquefaction-prone sites	3.9
Figure 3.4:	Influence of wall and foundation stiffness on settlement	3.13

Figure 3.5:	Panel base fixing detail illustrating potential crack locations.....	3.18
Figure 3.6 (a):	Schematic plan layout of example building 1 featuring an incomplete load path	3.20
Figure 3.6 (b):	Schematic plan layout of example building 2 incorporating a lack of symmetry.....	3.21
Figure 3.7:	Detailed assessment process.....	3.23
Figure 3.8:	Indicator criteria for wall systems	3.30
Figure 3.9:	Indicator criteria for frame systems	3.31
Figure 3.10:	Example building	3.32
Figure 4.1:	Derivation of load actions from loss of support.....	4.14
Figure 4.2:	Possible panel restraint system for lintel elements	4.17
Figure A.1:	Section through suspended floor/bearing wall connection in timber-framed construction.....	A.3
Figure A.2:	Section through foundation to floor connection in Type B construction.....	A.4
Figure A.3:	Section through shell/precast beam to hollow core floor connection in suspended floor system	A.5
Figure A.4:	Section of precast panel wall and roof steelwork connection	A.6
Figure A.5:	Steel weld plate to wall panel connection	A.7
Figure A.6:	Wall elevation with lintel panels	A.8
Figure C1:	Vertical panel joints	C.3
Figure C2:	Free body analysis of panel behaviour.....	C.3
Figure C3:	Representative yield line pattern	C.5
Figure C4:	Possible arrangement of repair elements.....	C.6
Figure C5:	Tributary area to connections	C.8

Tables

Table 3.1:	Activity descriptions.....	3.2
Table 3.2:	Usage dependent floor level indicator criteria	3.26
Table 3.3:	Structure and foundation categorisation.....	3.27
Table 3.4:	Indicator criteria for damage assessment to superstructure (Table 3.4 extends over two pages: 3.28 and 3.29).....	3.28
Table 3.5:	Inferred level differential over 6m for wall system from Figures 3.8(a) and 3.8(b) above.....	3.30
Table 3.6:	Inferred level differential over 6m for frame system from 3.9(a) and 3.9(b) above	3.31
Table 4.1:	Recommended repair approach for panels and fixings	4.8
Table 4.2:	Common problems and solutions for industrial buildings.....	4.20
Table B1:	SLS performance expectations for industrial buildings.....	B.1

1. Introduction

1.1 Background

Industrial buildings are characterised by their use rather than their structural form or materials. Typically the building's value is low compared to the value of the process that is housed in the building. Often, the building may have been purpose built specifically for the industry requirements. This creates a different set of circumstances, for example, to commercial office buildings, where floor space is typically generic in nature.

The needs of industrial tenants and building owners are different from those of commercial office and retail buildings. Industrial building occupants cannot generally move because their plant is specialised. They may have long lead-times to replace and/or reinstall plant and have supply contracts that have to carry on uninterrupted.

The Canterbury earthquakes have caused severe damage to the local industrial building stock, particularly in eastern and southern Christchurch. There is a need to consider appropriate criteria for the occupancy and repair of the earthquake-damaged buildings.

1.2 Scope

This document is intended for the assessment and repair of industrial buildings potentially affected by the Canterbury earthquake sequence. The use of this document is limited to the three main Territorial Authorities in the Canterbury area: Christchurch, Waimakariri and Selwyn.

The focus of this document for existing buildings is:

- › emphasising the key initial step of understanding the building in its current (damaged) form
- › establishing the extent of pre-existing damage
- › establishing the extent of earthquake damage
- › following a triaging approach: do nothing; repair or relevel; or rebuild
- › assessing and repairing where necessary (including replacement of limited numbers of elements on a comparable basis)
- › identifying vulnerabilities and inadequacies
- › concentrating on existing use, not future resale.

The focus of this document for new buildings is on the reuse of potentially liquefiable sites in ways that do not render the redevelopment uneconomic. Refer to section 5.

Although this guidance is generally applicable to all industrial facilities, judgement must be exercised in respect of buildings or elements that require specialised engineering evaluation beyond the scope of this document. This may include:

- › heavy plant or equipment that forms part of (and modifies the behaviour of) the building structure
- › heavy plant or equipment foundations that have specific dynamic performance characteristics and/or that have specific settlement and movement criteria
- › buildings containing hazardous contents or processes
- › This guidance is NOT intended for use in the determination of insurance outcomes, which are a contractual matter between insurer and insured, and hence are outside the scope of this document.

1.3 Guiding principles

In the Canterbury Detailed Engineering Evaluation (DEE) guidance¹, the primary purpose was to identify where earthquake damage had occurred and what the implications of the damage might be to future performance. Repair was not specifically addressed, noting that the majority of buildings were subject to insurance claims and would have levels of repair and strengthening determined accordingly.

The need to maintain processing operations in industrial buildings requires a different approach to repair than would apply to other commercial buildings. Acknowledging this, the focus of this guidance is on the current occupancy and use, rather than on future resale or property value.

The guiding principles used in this document are:

- › to establish reasonable assessment criteria that recognise the particular requirements of these buildings, without being too restrictive
- › to enable continued occupancy and operation of industrial buildings while undertaking the necessary repairs
- › to establish a compliance path that will not impose requirements for upgrading or rebuilding that are more onerous than the baseline required by the legislation.

1.4 Building construction types

Industrial buildings are common throughout Christchurch and exist in various forms from unreinforced masonry (dating from the 1800s in some cases) through to the current most prevalent form of concrete tilt panels supported by steel frames. Tilt panels have been popular for industrial buildings since the introduction of tilt up construction in the late 1950s. Other forms of construction include concrete frames with masonry infill panels, fully or partially filled reinforced concrete masonry, and fully lightweight systems. Tilt panels may be full or partial height systems, depending on durability requirements and fire-rating issues.

¹ Ministry of Business, Innovation & Employment, Engineering Advisory Group. (2012). Draft Guidance on Detailed Engineering Evaluation of Earthquake Affected Non-residential Buildings in Canterbury, Part 2 Evaluation Procedure. Retrieved from <http://sesoc.org.nz/images/Detailed-Engineering-Evaluation-Procedure.pdf>

Most roof systems are lightweight, with most modern industrial buildings using profiled steel sheeting on metal purlins, supported by steel portal frames or trussed roofs. Older industrial buildings have asbestos cement roofing over timber or metal purlins with a range of roof profiles including conventional portal frames, south-light trusses, and post and frame construction.

Ground floors are typically concrete slabs on grade, often reinforced with cold drawn wire mesh, although more recent industrial buildings may incorporate conventional mild steel reinforcing or even post-tensioning. Older industrial buildings may use unreinforced floor slabs.

Some specialised buildings may incorporate lightweight insulated panel systems for the roof or walls.

Note:

An industrial building may contain asbestos, either as a result of its construction, or from a processing plant contained within the building. Engineers and other advisors should generally ensure that they have addressed this potential hazard in consultation with the owners and occupiers.²

1.5 Context

Many of the structures covered under this guidance are concentrated to the east and southeast side of Christchurch city, in suburbs such as Bromley and Woolston. Building behaviour in these areas has typically been governed by soft and liquefiable soil behaviour, making ground deformation a significant component of building assessments.

A number of these buildings are uninsured or at least under-insured. This, coupled with the occupiers' need to maintain their operation in spite of damage incurred, has dictated a different approach to damage assessment and subsequent repair or replacement.

These buildings have a relatively low ratio of total building area to plan footprint area, with most industrial facilities being single storey. Remediation is influenced by the (potentially) disproportionately high cost of deep foundations or ground improvement for such buildings. The cost of rebuilding could easily double if ground improvement or deep piling were to be considered for the entire area of such facilities. This could make redevelopment uneconomical and yet they currently support a significant proportion of the local economy.

This guidance is intended to explore ways of maintaining the viability of these areas by providing a pragmatic path through the assessment, repair and rebuilding process.

² Department of Labour. (2012). Factsheet: Disaster Recovery – Asbestos Management. Retrieved from www.dol.govt.nz/quake/asbestos-management.pdf

1.6 Building ownership

It is important to establish ownership obligations before commencing work. There are legal factors to consider where industrial buildings are not standalone. The nature of ownership has a bearing on whether repairs will be isolated or taken across whole buildings. The latter approach is the preferred alternative but may not always be possible.

1.7 Building purpose

While many industrial buildings are purpose built for a particular use, there are also many that are for general use and may be expected to have several changes of use during their design life. Tolerable deformation for an initial use may be unacceptable for a later use. To provide some level of protection for later owners and/or users, but allow flexibility in design, the design criteria must be explicitly and prominently stated in consent documentation if the design allows greater than normal deformation.

Building owners may decide to incorporate increased resilience into the building, possibly for future insurance considerations, by adopting an approach which may result in exceedance of generally accepted design criteria, eg settlement under seismic action. Designers are reminded that their role is not to make decisions about critical matters on behalf of their clients; rather they need to ensure that they provide good advice to their clients in order that clients have a good understanding of the implications of their decisions.

2. Performance expectations

This section covers regulatory and performance matters that are common to all industrial buildings, whether being repaired or rebuilt.

2.1 Regulatory requirements

2.1.1 Regulatory considerations

Applicable legislation and regulations include:

- › Building Act 2004, especially sections 17¹, 112, 121, 122, and 124
- › Canterbury Earthquake Recovery Act 2011 (CER Act)
- › Health and Safety in Employment Act 1992 (HSE Act)
- › Christchurch City Council's Earthquake-prone, dangerous and insanitary buildings policy 2010 (CCC's EPB policy)
- › Hazardous Substances and New Organisms Act 1996.

The need to complete assessment and repairs of buildings can be initiated in several ways, including:

- › by owners proactively considering the ongoing use of their building and the safety of the occupants
- › by action consequent to placarding of a building following the earthquakes
- › by the invocation of sections 29 or 51 of the CER Act, requiring owners to complete assessments of their buildings
- › consequent to a claim under an insurance policy.

No matter which of these has initiated the assessment, the assessment requirements are generally the same although the path to eventual repair or rebuilding may be different.

In addressing the assessment of buildings, the most immediately relevant legislation is the Building Act. The extensive repair requirements in Christchurch were not envisaged when the current legislation was enacted and this has led to challenges in interpretation. Repair work is included under the requirements for alterations under the Building Act. However, the assessment of earthquake-damaged buildings is not covered by any particular requirements. Detailed evaluations, where requested by the Canterbury Earthquake Recovery Authority (CERA) under the CER Act, have been required to comply with the Detailed Engineering Evaluation (DEE) Guidelines².

1 Section 17 of the Building Act 2004 states that "all building work must comply with the building code to the extent required by this Act, whether or not a building consent is required in respect of that building work."

2 MBIE Engineering Advisory Group. (2012). Draft Guidance on Detailed Engineering Evaluation of Earthquake Affected Non-residential Buildings in Canterbury, Part 2 Evaluation Procedure. Retrieved from <http://sesoc.org.nz/images/Detailed-Engineering-Evaluation-Procedure.pdf>

A key objective, but not the only objective, of the DEE assessment is to determine whether damage that has occurred is of significance, that is, whether the building's structural capacity has been significantly diminished by the earthquakes. The DEE will also provide an assessment of the post-earthquake building capacity. It is conceivable that a building that may be considered earthquake-prone under section 122 of the Building Act has suffered no significant damage. In such cases, the building may be required to comply with the CCC's EPB policy in the future, but there is no immediate compulsion on owners to do so.

The DEE reports requested by CERA are progressively being handed over to the territorial authorities, in the main Christchurch City Council. When presenting applications for building consent to the Building Consent Authority (BCA) to undertake repairs, the DEE report should be included. These reports will indicate the seismic capacity of building in the earthquake-affected state. The territorial authority will then use this information to update or populate their earthquake-prone building register. It will be important to notify the territorial authority of the new assessed capacity of the building, once the repairs have been undertaken. Otherwise the register will continue to have the pre-repair capacity recorded and may continue to be classified as an earthquake-prone building. It is important to note that in the Canterbury context an Initial Seismic Assessment (ISA) report may not pick up all of the earthquake damage that may have occurred and in order for owners to properly consider the safety of occupants and persons near their buildings a DEE report is recommended for all industrial buildings.

In cases where a building's capacity to resist future earthquakes has been significantly reduced, there is a need to consider carefully what repair or strengthening action might be required. If the building capacity has been reduced to a level where it is now earthquake-prone, it may still be in a condition to be considered dangerous. For a building to be dangerous under the Building Act (section 124) there needs to be an imminent danger to occupants. It is a different test to being earthquake-prone and earthquake action is not part of the consideration. For a time, immediately post the earthquakes in Canterbury, an Order in Council³ did consider aftershocks as a consideration for being dangerous, but this has now expired. However, a building that has demonstrably reduced in capacity through the earthquakes is clearly at risk of further deterioration and there may be no way to predict at what point it will become dangerous in the common usage sense.

2.1.2 Building regulatory framework

The Building Act is the primary legislation for regulating building work in New Zealand. Building regulations, provided for under the Building Act, are secondary legislation that includes, among other things, the New Zealand Building Code (Building Code), lists specified systems, defines change of use and the moderate earthquake. The Building Code sets performance requirements for new buildings. At a tertiary level, MBIE has issued Acceptable Solutions and Verification Methods that are one way, but not the only way, of demonstrating compliance with the Building Code. The Standards that designers use in the design of new buildings are typically referenced in Acceptable Solutions or Verification Methods as a means of satisfying the performance standards in the Building Code.

.....
3 Canterbury Earthquake (Building Act) Order 2011.

All building work must comply with the Building Code regardless of whether a building consent is required. This includes work for, or in connection with, the construction, alteration, repair, demolition, or removal of a building.

The scope of building work needing to be undertaken will depend on the assessment outcome and whether the building is to be rebuilt or repaired.

If a new or replacement building is required, the new building will need to comply with the performance requirements of the Building Code. For statutory requirements for rebuilds in liquefaction-prone areas, refer to section 5.2 of this document, in addition to the discussion in this section.

If repairs are to be undertaken, the extent of the work will depend on the outcomes of the assessment process, and the degree to which owners and/or users are able to accommodate a reduced level of amenity either in the repaired structure or in the event of future earthquakes. It is only the building work actually being undertaken as part of the repair that will need to fully comply with the Building Code. The overall performance of the repaired building may well not fully comply with all Building Code requirements, as is indeed the case for many existing buildings throughout New Zealand. However, in accordance with section 112 of the Building Act, the repaired building as a whole needs to comply with the Building Code to at least the same extent as before repairs took place (ie not to the state it was before the earthquake, but before repairs were carried out). Exceptions apply for means of escape from fire and for access and facilities for persons with disabilities. Both are required to comply, as nearly as is reasonably practicable, with the provisions of the Building Code.

Refer to section 4.2 of this document for further discussion on regulatory requirements for repairs and for technical guidance to design repair solutions.

2.1.3 Building Code structural requirements – Clause B1

As noted above, the extent to which a building must comply with the requirements of the Building Code will vary according to whether the building is being repaired or rebuilt; and if being repaired, the extent to which the relevant sections of the Building Act are triggered.

The Building Code requires buildings or building elements to be designed to “withstand the combination of loads that they are likely to experience . . . throughout their lives” (B1.2). In addition, “Buildings, building elements and siteworks shall have a low probability of rupturing, becoming unstable, losing equilibrium, or collapsing during construction or alteration and throughout their lives.” (B1.3.1); and “shall have a low probability of causing loss of amenity through undue deformation, vibratory response, degradation, or other physical characteristics throughout their lives...”(B1.3.2).

The performance standards of B1.3.1 and B1.3.2 split broadly into the ultimate limit state and serviceability limit states respectively, as described in AS/NZS 1170.0.

2.1.4 Rupture and instability (NZBC B1.3.1)

Rupture and instability is the primary issue to be addressed, as it impacts directly on life safety. Achieving an acceptable level of risk to life safety is a principal objective, whether the building is to undergo repair or replacement.

For the purposes of structural design, 'rupture' of a building should be considered as the condition of having exceeded the ultimate limit state capacity of the building as a whole, with regard to its ductility and deformation capacity. It is important that engineers consider the capability (or otherwise) of the building as a whole to redistribute seismic actions in the event of a single element reaching its limit, as well as the implications of increasing displacement for an element that has exceeded its capacity. In other words, a building's capacity is not limited by the capacity of its weakest element provided that the balance of the building can continue to resist increasing seismic actions.

This concept is widely used in design, where redistribution is an accepted practice. The 'deemed to comply' provisions of the Standards generally ensure that elements of the building will satisfy the more demanding drift requirements of large earthquakes without the need for extensive element drift and rotation checks.

Allowing for the redistribution of loads is equally acceptable in assessment, although the consequences of element deformation capacity may need to be considered explicitly where the elements do not otherwise comply with the 'deemed to comply' detailing requirements of current Standards. In these cases, reference should be made to the NZSEE Guidelines⁴ which give more detailed guidance on acceptable performance.

For isolated building elements whose failure may cause harm (such as parapets or lintels), this may be considered as the capacity of the element itself, but with regard to the consequence of failure of the element. That is, if an element fails in a way that does not present a danger to users or the public, it may not be a defining element for the assessed building capacity. Conversely, if the failure of an element does cause danger to users or the public, it will require mitigating to an acceptable level.

2.1.5 Loss of amenity (NZBC B1.3.2)

Loss of amenity is one of the critical issues to consider when determining a repair or replacement strategy, particularly when dealing with large (in plan area) structures on potentially liquefiable ground. Amenity is not required (by the Building Act) to be specifically addressed in simple repairs but its consideration should inform the decision making process, noting that continued use of buildings after future earthquakes is a desired outcome of the repair process.

.....
⁴ New Zealand Society for Earthquake Engineering Inc. (2014). Assessment and Improvement of the Structural Performance of Buildings in Earthquakes. Retrieved from [www.nzsee.org.nz/db/PUBS/2006AISBEGUIDELINESCorr3_\(incl_2014_updates\).pdf](http://www.nzsee.org.nz/db/PUBS/2006AISBEGUIDELINESCorr3_(incl_2014_updates).pdf)

Loss of amenity may be considered as the condition of exceeding the following tolerable impact:

All parts of the structure shall remain functional so that the building can continue to perform its intended purpose. Minor damage to structure. Some damage to building contents, fabric and lining. Readily repairable. Building accessible and safe to occupy. No loss of life. No injuries.⁵

The principal difference between industrial amenity and amenity in other categories of building (eg residential) is that the industrial operations can often tolerate a wider gap between new and repaired in respect of the scope of repair and future potential damage. This assumes that resale value is a significantly lower priority than maintenance of current use. This is a key consideration of the guiding principles noted in section 1.3 of this document.

Physical effects that may be considered with respect to loss of amenity could include loss of services including sewer and water connections, damage to sanitary fixtures, parts of the building being no longer available, significant cracking and deformation of flooring, or the building envelope not being weathertight. Measures should be taken when designing and building foundations on land with the potential for liquefaction to minimise the possibility of loss of amenity, should a significant earthquake event occur.

For sites that have significant liquefaction potential, closer consideration of the effects of future movement may be required. Particularly if the building use is generic and readily relocatable (eg low-level warehousing), owners and users may be prepared to accept future damage that is of the same order as that which has already been experienced. If the building requires minor repair only, the repair and compliance process is relatively straightforward. Refer to section 4.3 of this document for further guidance.

If this level of damage would be unacceptable in the future, then a repair or replacement strategy that changes future behaviour will have to be developed. Refer to section 4.4 of this document for further guidance on major repairs and section 5 for guidance on rebuilding.

2.1.6 Repairability

While not explicitly addressed in NZBC B1, a degree of repairability is implicit through the loss of amenity requirement. A further consideration is that for a building to be considered truly repairable, the required repairs should be economically viable. This becomes critical when considering the nature of future damage that may be tolerated when reviewing the repair or replacement strategy.

Appendix B provides guidance on the tolerable impacts for industrial buildings that may be considered acceptable in future SLS level earthquakes. These are recommendations provided for guidance only, and are generally focused on replacement buildings. However, they may also provide guidance on performance objectives to inform the repair process.

.....
⁵ Lawrance, G.M., Hopkins, D.C., Cheong, D.P.H., & Stannard, M. C. (2014, March). Review of the Building Code Structural Provisions. Paper presented at the 2014 NZSEE Conference, Auckland. Retrieved from http://db.nzsee.org.nz/2014/oral/37_Lawrance.pdf

2.2 Liquefaction

Buildings on soils which have suffered liquefaction have generally provided adequate protection against injury or loss of life, except where elements have had inadequate capacity to absorb the significant imposed deformations that have resulted from differential settlement. However, the function of buildings has in many cases been compromised and not all such buildings have been readily repairable.

It is important to consider the intensity of shaking (and hence the return period) at which liquefaction may become significant. By convention, if the shaking level at which liquefaction is initiated is greater than the serviceability limit state (SLS) event (typically a 25 year earthquake, noting that, for Canterbury only, this equates to $R=0.33$), then loss of amenity is considered to have been satisfied. However, it should be noted that liquefaction tends not to follow a linear progression.

With the increased Z and R factors there is more land in Christchurch that is likely to liquefy at an SLS level of shaking. For residential buildings, the MBIE Residential Guidance recommends that differential settlement across the building should be no more than 50mm with the building remaining functional and without damage that would impact on the structure's amenity. However, for large industrial buildings these criteria may be unnecessarily severe and a greater tolerance may be permissible for some buildings, provided that the structure remains functional. On the other hand, there are also buildings where even small settlements may impact on the functioning of the housed activity (eg forklift access for high racking or machine alignment). The owners' and users' expectations should be discussed and taken into account in addressing amenity after future earthquakes and this should determine the repair or rebuild strategy.

The acceptance or mitigation of liquefaction settlement needs to be looked at carefully for the particular use of each structure. On liquefiable sites, this may also require geotechnical testing of the site to determine likely ground behaviour and deformation. Refer to section 3.2 of this document for further guidance.

2.3 Special legal issues

2.3.1 Safety in carrying out work

In undertaking assessment, repairs, and rebuilding, particular attention needs to be paid to health and safety requirements. Work must comply with the Health and Safety in Employment Act 1992 (HSE Act), the Hazardous Substances and Organisms Act 1996, and the various regulations made under these Acts. Where assessment and repairs are being carried out on damaged buildings, access plans should be prepared to highlight areas of concern and to put in place management strategies to avoid or minimise risk. In the first instance, this should include a detailed hazard assessment of the building. Shoring and temporary repairs may need to be implemented before full assessment can be undertaken.

Where repairs are undertaken and there is a possibility of asbestos being present in the building, refer to the MBIE fact sheet 'Disaster Recovery – Asbestos Management'⁶.

⁶ Department of Labour. (2012). Factsheet: Disaster Recovery – Asbestos Management. Retrieved from www.dol.govt.nz/quake/asbestos-management.pdf

2.3.2 Seismic risk management and health and safety concerns

Health and safety objectives are central to any remedial work. Industrial buildings have their own requirements that must be in place before a property is recommissioned. However, it is necessary to consider the difference between health and safety in the normal operations of the facility and concerns arising out of seismic hazard.

Commencing with a macro assessment, it is then necessary to follow through to the detail due to the wide variety of industrial structures. The macro issue is illustrated in Figure 2.1. In this case, building A, which is technically earthquake prone, has had no reduction in capacity; whereas building B has steadily reduced in capacity over the course of the earthquake series. Even though it may be assessed as initially having greater capacity than building A, building B is in more need of repair. This is because the earthquake-prone building (EPB) rating is a coarse prediction of future performance, whereas the actual performance is observation based. The observation confirms that building A has reserve capacity while the deterioration in building B is evidence of vulnerability.

It is also accepted that the status of building A should be addressed either by closer review of the EPB rating or by upgrade to 33% to meet the expectation of a wide range of earthquake scenarios. However, this is not linked to earthquake repairs and could be undertaken at a later date in accordance with the earthquake-prone building policy.

Figure 2.1: Building capacity through earthquakes

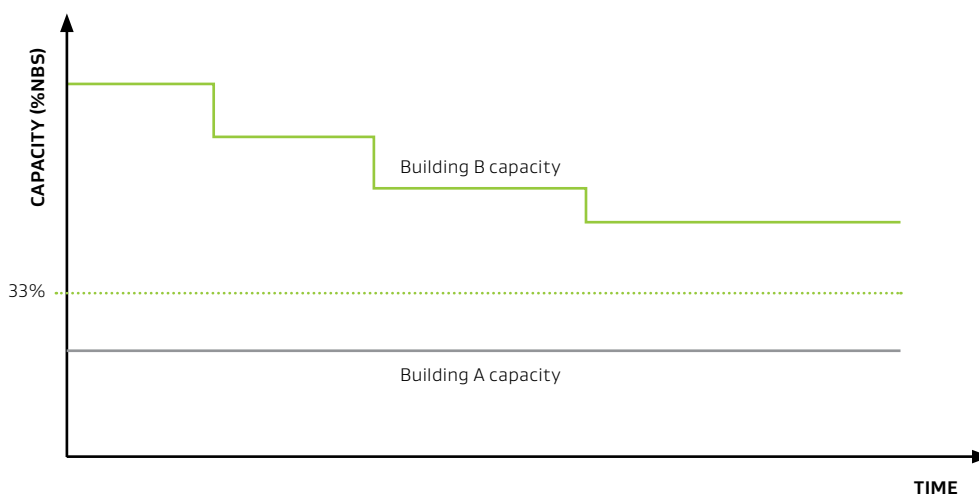

Section 6 of the HSE Act requires employers to take all practicable steps to ensure the safety of employees, including to “provide and maintain for employees a safe working environment”. The standard to apply is that of a well-informed owner taking reasonable care to protect the health and safety of occupants. Worksafe New Zealand has advised:

If you are doing what you're supposed to be doing under the Building Act, (including following a plan over the timeframe set by the Territorial Authority, to address an earthquake-prone building's status), then we are not going to enforce to a higher standard in relation to your building's earthquake resilience under the HSE Act. If you're not doing what you should be doing under the Building Act, we expect the relevant local council to take action.⁷

If you're not doing what you're supposed to be doing under the Building Act and someone is seriously harmed following an earthquake you could face enforcement action under the HSE Act.

This is not intended to mean that earthquake-prone buildings should be immediately strengthened. Rather, it allows for a long term hazard reduction programme to be developed and followed, whereby a building will comply with the local Territorial Authority EPB policy within the allotted time. Hence, building performance during and after earthquakes should not be considered an HSE Act issue unless the building is in a deteriorating condition as noted above (Figure 2.1) or inadequate action has been taken over direct potential harm hazards.

Temporary propping or repairs to allow occupation for assessment and repair or for normal operations to continue must address worker safety and may be required to allow an accelerated return to occupancy and use. Temporary repairs that have been implemented to allow continued use of buildings should be replaced with permanent repairs at the soonest opportunity, or should be consented and made permanent. This will require consideration of matters other than strength, with durability being an obvious consideration in many cases.

Of further significance in respect of the HSE Act are the possible secondary impacts of movement and damage, particularly to floors. Significant movement in ground floor slabs, due to liquefaction and/or settlement, can lead to offsets or changes in slope that may increase risk of accident. This may be highly subjective, depending on the nature of the use. For example a warehouse with high level stacking may have considerably tighter tolerances on floor slope and offsets than a light manufacturing facility. Assessors must take the time to understand the appropriate tolerances for the nature of the business being conducted in a facility in order to address short term and long term solutions.

Secondary effects of movement must also be considered, that is the impact of movement and damage to non-structural elements. In particular, in-ground services may have been damaged by the earthquakes, either through movement causing fracture of pipes, or with differential settlement causing a change in falls, potentially affecting drainage at either roof or ground level.

⁷ WorkSafe New Zealand. (2014). Position Statement – Dealing with earthquake-related hazards: Information for employers and owners of workplace buildings. Retrieved from www.business.govt.nz/worksafe/information-guidance/all-guidance-items/position-statements/position-statement-dealing-with-earthquake-related-hazards/

Finally, assessors should remember to include consideration of all sections of the Building Code to arrive at solutions that provide compliance. Fire regulations in particular may require specific consideration, noting that matters affecting escape from fire must be addressed under section 112 of the Building Act. The building's pre-event evacuation scheme may have been dependent on protected egress that has been disturbed by damage or modification. Similarly where disabled access requires reinstatement to meet section 112 requirements the requirements need to be addressed in the early stages of repair and before the facility is recommissioned.

2.3.3 Flood risk and floor levels

The flood risk in Christchurch has increased in many areas, due to a number of factors including constriction of the waterways and global settlement.

Building Code Clause E1 requires buildings and site work to be constructed in a way that protects people and other property from the adverse effects of surface water.

Clause E1.3.2 requires floor levels for Housing, Communal Residential and Communal Non-residential buildings to be set above the 50-year flood level. This requirement does not apply to industrial buildings.

There may be instances of buildings within the scope of this guidance for which E1.3.2 does apply (eg a mixed use development with a residential component). For these, refer to Part B Section 8.4 of the MBIE [Guidance: repairing and rebuilding houses affected by the Canterbury earthquakes](#) (MBIE Residential Guidance).

This will only be an issue for the construction of a new building and in this case it would be recommended that floor levels meet the one in 50-year provision.

In cases where the residential component of the building occurs at a level above the ground floor, further specialist advice or a Determination (ie a binding decision made by the Ministry under section 177 of the Building Act) may be required.

3. Assessment

3.1 Recommended assessment approach

This section presents a general approach to the engineering assessment of industrial buildings. Emphasis is given to the unique aspects of industrial buildings including recognition of the relative importance and inflexibility of plant within the buildings. The assessment approach needs to balance the structural vulnerabilities, amenity values, and repair strategies.

The general purpose of the assessment is to determine whether movement has impaired the future structural performance of the buildings or not.

A staged approach to assessing earthquake-damaged industrial buildings is recommended. In a staged approach, broad options are developed for the repair and/or rebuild to assess the project's feasibility. This may be achieved with minimal geotechnical investigation (as described in section 3.2 of this document) provided that building vulnerabilities and repair or replacement requirements are identified considering the range of future behaviours.

A high-level structural assessment is the key initial stage, allowing consideration of alternative repair or rebuild strategies that focuses on the user's needs. Once a strategy decision has been made, further investigation and the engagement of engineers and advisors may follow.

Figure 3.1 illustrates the iterative nature of the assessment process. The steps in the assessment are summarised in the following subsections, noting that the focus of the overall process is to develop an understanding of the vulnerability of the building.

Figure 3.1: General assessment approach

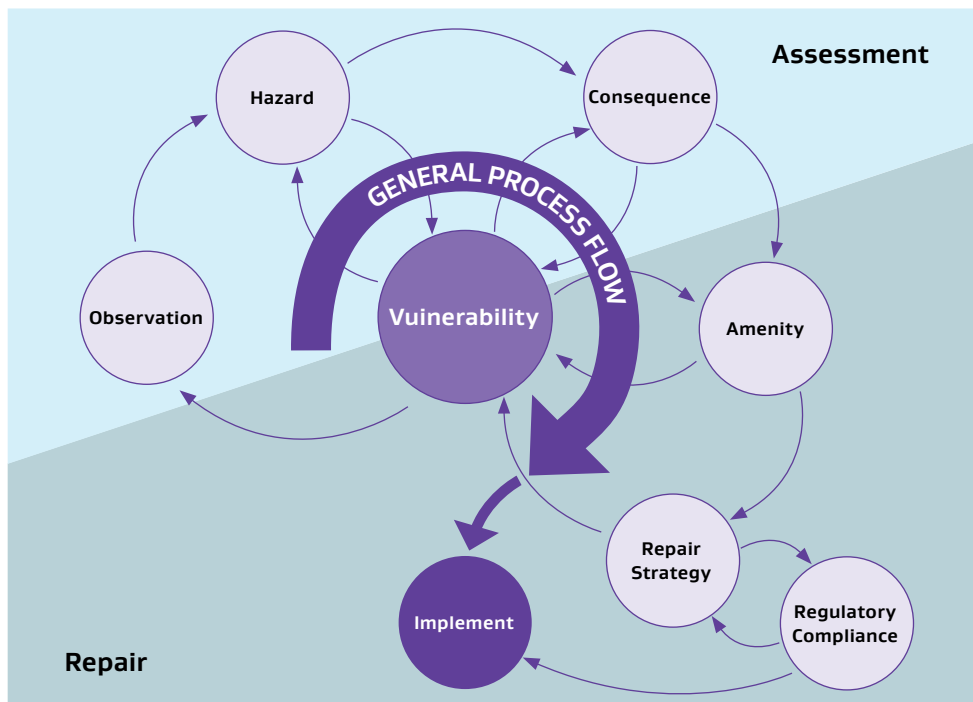

3.1.1 Observation

This covers all of the information and data gathering activities that will inform the assessment, including (but not limited to) the activities listed in Table 3.1.

Table 3.1: Activity descriptions

Activity	Description
Building records	The assessor should gain a sound understanding of the building. This may include, where possible, drawings, specifications and other data from construction or subsequent alterations. Sources include the owner, original designers and local BCA.
Visual survey and photographic record	The assessor should look for visual indications of movement that may indicate damage and the need for a more detailed assessment.
Assess building site	The assessor must consider global aspects of the site behaviour that may impact on the performance of the building. The purpose of this is not to consider land damage as a component of the overall property damage, but rather to ensure that matters that affect the building behaviour have been identified. Typical matters to consider include: <ul style="list-style-type: none"> › If significant settlement has occurred, is there an increased likelihood of liquefaction as a consequence, or is the likelihood of future settlement unchanged? › Is there lateral spread and if so, how has this impacted on the building? › Is the surface drainage around the building still working acceptably and is there an acceptable margin between the ground floor level and/or cladding and the surrounding finished ground level?
Survey	This may include a verticality and floor level survey. A floor level survey should include levels along the line of rigid elements such as wall lines, as well as open areas of floor on a grid basis.
Geotechnical investigation	This should be appropriate to the observed movements and hazards. For further guidance on the form and extent of the geotechnical survey refer to section 3.2 of this document.

For buildings where differential settlement or foundation movement is suspected, a detailed level survey should be undertaken. In order to assess the effect of movement, this survey will need to include measurement of levels on the main structural support lines as well as a simple grid survey on the ground floor slab. To identify pre-existing floor settlement, the level surveys should also measure suspended floors to get a comparative measure of overall vertical settlement.

It is critical that assessors consider not only the movement and damage that is observed but also its possible causes. Many untrained or inexperienced observers may be tempted to conclude that all visible movement or damage is related to the earthquakes, but this is often not the case and may lead to incorrect assumptions and recommendations. This may not always lead to a conservative or desirable outcome.

The passage of time since the events that may have caused the damage must also be carefully considered. There are often tell-tale signs of the original locations of key elements that can be used as a guide to the earthquake movement. Equally, care should be taken to recognise where repairs (of acceptable quality or not) may conceal damage that should be accounted for in the assessment. It is also worthwhile to check whether an earlier inspection has been carried out (under Civil Defence authority or otherwise) and if so, what records exist. It is often useful to understand an earlier assessor's opinion even if that opinion was based on incomplete observations.

3.1.2 Site hazards

Given the observed building performance and damage, determine the possible site hazards that should be considered in the assessment.

While earthquake damage is the primary consideration of the assessment, consideration must be given to other hazards that may have been triggered or exacerbated by the earthquake damage, for example increased liquefaction hazard or flood hazard. The impact of land contamination may have been magnified.

3.1.3 Vulnerability

Following the hazard assessment, the facility's vulnerabilities may be assessed. This may, in turn, trigger the need for further observation (review of damage observations in key areas of assessed vulnerability) and revision or reassessment of the potential damage issues that may have been identified during the review of the building records.

3.1.4 Consequence

The criticality of the vulnerabilities and hazards must be considered. This should take into account both life safety hazard (the primary issue) and potential impact on the use of the facility. Where the potential consequence of future hazard events is unacceptable, temporary repairs or shoring may be required to allow continued use until permanent repairs can be completed.

3.1.5 Amenity (use of the facility)

It is important to note that unlike many commercial structures for which the building itself is the primary source of revenue (eg an office building for lease); industrial buildings generally house a process that is the main source of revenue. As many industrial buildings have been designed or adapted around a particular process, it is important that the users' requirements are thoroughly considered. Special attention should be paid to health and safety matters that may be affected by building movement or damage (refer also sections 2.3.1 and 2.3.2), in particular:

- › floor slopes, noting that displacements in excess of normally acceptable limits may be tolerable, provided that there is no disruption to the building use, and there is no significant increase in hazard to workers, eg trip hazards
- › reduced clearances and/or restricted access caused by building movement and propping or shoring.

3.1.6 Repair or rebuild strategies

One or more repair or rebuild strategies may be developed based on an understanding of the damage, consequence, and continuing use requirements for the building, as determined from the assessment. The repair strategies developed should include consideration of:

- › legal requirements under the Building Act with regard to whether the proposed building work will require a building consent, noting that all building work must in any case comply with section 17 of the Building Act
- › the users' health and safety policy, as may be amended to suit any building reconfiguration or alteration as a result of the repairs
- › an integration of structural and geotechnical considerations.

Repair and rebuild strategies are covered in more detail in sections 4 and 5 of this document.

3.2 Geotechnical considerations

This section frames the industrial building sites where there is potential for liquefaction and lateral spread.

3.2.1 Ground performance

Industrial/commercial buildings in the west of Christchurch city from north of the airport through to Hornby and Sockburn, have generally not suffered significant foundation damage, as these areas are generally underlain with better gravel soils and lower water tables. Other industrial/commercial zones in the city, including Sydenham, Waltham, Linwood, Woolston, Ferrymead and Bromley, contain areas with significant liquefaction damage. On some of these sites the existing damaged buildings have been demolished because of the liquefaction damage. The underlying soil profiles vary, but often there are liquefiable sands to depths of 10-15m and in some parts of Linwood and Bromley it can be as deep as 20-25m. Most industrial land in Christchurch is removed from steep river banks that might induce lateral spread. One area that is close to river banks is the lower Heathcote area, yet this was well tested in the February 2011 earthquake, with lateral spread limited in both extent and magnitude. Therefore, lateral spread has not been observed to be a significant problem for most industrial buildings in Christchurch.

The primary issue is how to establish assessment criteria for industrial/commercial buildings on sites with significant liquefaction and ground damage where lateral spread is largely absent.

Readers are referred to the MBIE Residential Guidance. Although that document was prepared primarily for the repair and rebuilding of residential buildings, there may often be similarities in behaviour and performance of some elements of industrial or commercial buildings. In such cases, the same approaches may be used with adaptations and by applying engineering judgement, noting that:

- › the standards required for industrial buildings are not the same as those which apply for residential uses
- › buildings are typically larger and thresholds for acceptable floor levels and floor gradients are different.

Refer also to interpretation and comments in Appendix B.

3.2.2 Building response to liquefaction

The previously published general guidance for geotechnical assessment for commercial buildings was directed primarily towards commercial development of a different scale and in different circumstances to the buildings under consideration in this document. A key difference is that for industrial buildings that have suffered only moderate damage and require repair on a limited (or comparable) basis, it is not considered that a full-scale deep soil investigation is required as a matter of course.

A key consideration is the extent of future shaking damage that may be expected to occur, relative to what has happened as a consequence of the shaking experienced at the site to date. For the eastern areas of the city such as Bromley and Woolston, it may be considered that the cumulative extent of shaking damage and consequential site effects such as liquefaction may be reasonably representative of future earthquakes approaching a full ULS event. The Sydenham – Waltham – Linwood area was not as strongly shaken in the February and June 2011 earthquakes, but has still been tested to well above SLS levels.

Industrial buildings often have a high tolerance to ground movement, provided that the stiff elements such as walls are strong enough to impose a uniform behaviour on the soil. This may manifest in either (or a combination of) two forms of movement:

- › uniform tilt on a constant or near constant slope, or
- › uniform settlement of the structure, with differential settlement across the ground floor.

These are represented in Figures 3.2a and 3.2b.

Alternatively, differential settlement will result if the structure does not have the strength and stiffness to impose uniform movement. This is represented in Figures 3.2c and 3.2d.

Figure 3.2: Settlement patterns

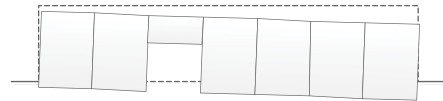
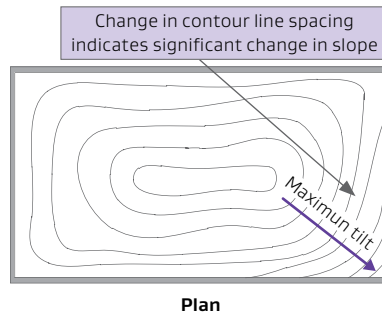
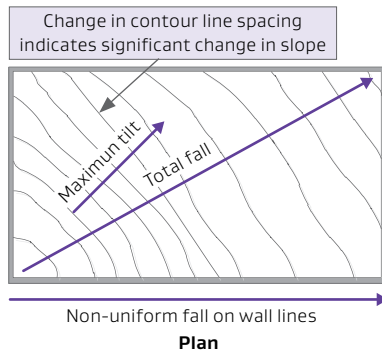
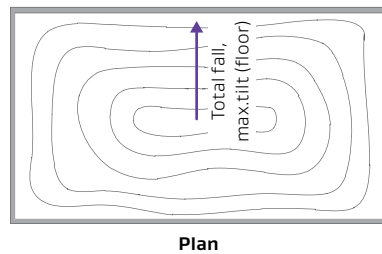
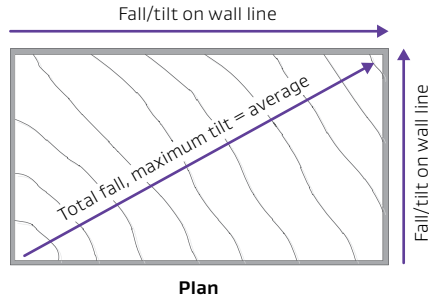

a) Uniform tilt. Indicated by approximately even spacing of contours. Minimal impact of movement on structure although residual stresses in connections should be considered carefully.



b) Uniform settlement. Indicated by approximately level perimeter structure, accompanied by apparent 'heave' of floor. Minimal impact of movement on structure although residual stresses in connections should be considered carefully.

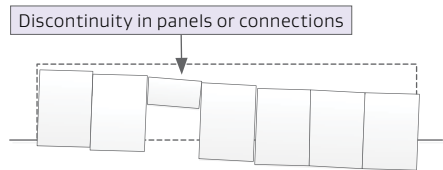

c) Differential settlement (tilt). Indicated by variable spacing of contours. May result in stress and/or fracture of structural elements or connections.



d) Differential settlement. Indicated by variable spacing of contours, with apparent 'heave' of floor and/or drop-off in isolated areas, often towards corners. May result in stress and/or fracture of structural elements or connections.

3.2.3 Lateral spread

Although lateral spread has not been a significant problem for most industrial buildings in Christchurch there are some sites where it will need to be considered.

Note:

Lateral spread does not only occur adjacent to existing watercourses; it may also affect other sites including historic watercourses.

Where a site is subject to lateral spread, any structure is likely to suffer settlement and some damage. The consequences of lateral spread of untied foundations (such as isolated pile caps or pads) on the structure's integrity at ULS should be considered in building assessments on vulnerable sites. It is important to note that if the ground floor slab is being relied upon to provide a lateral tie across the building, the effect of large cracks on the reinforcement should be considered. Conventional reinforcement may have sufficient ductility to maintain a tie force, but cold-drawn wire mesh is unlikely to survive a crack in excess of about 2mm. Piles also can be particularly problematic in lateral spread areas, as lateral ground movement can induce very large horizontal and eccentric vertical loads onto them, resulting in shear or bending failures.

Away from lateral spread zones, ground over liquefied soils can still experience lateral movements and permanent lateral displacements in either compression or extension. Lateral movement should be considered in the assessment of existing buildings and in the design of new ones. It is good practice to tie all foundations together to reduce the possibility of foundation displacement, ie separation. On vulnerable sites the consequences of lateral spread of 'untied' foundation elements, eg pads or pile heads, on the superstructure's integrity under ultimate limit state condition needs to be considered as part of any hazard assessment undertaken under section 3.1.

3.2.4 Geotechnical investigation

In determining the scope of soils investigation required, assessors should consider the nature of the work that is likely to be required and the additional information required to support it. There may be little to be gained from extensive deep soil investigations for the assessment and repair of many existing industrial buildings, even on sites where extensive liquefaction may have previously occurred. In such cases, the extent of investigation should instead be informed by the amount of movement to the structure, and consideration of whether further movement of the same magnitude could be tolerated. However, further investigation may be required if a releveling strategy is to be followed. This may be required by a specialist subcontractor, who may normally want to complete an investigation of their own, noting that some releveling techniques may have specific requirements that would not necessarily be anticipated by a more general geotechnical investigation.

It is recommended that engineers make owners aware that there is the potential for further geotechnical investigation being required, over and above what may be suitable during the assessment phase. This is most likely to apply in cases where releveling is being attempted, or where rebuilding is required.

3.2.4.1 Determining whether investigation is required

Figure 3.3 presents a general procedure to assist engineers in determining the scope of geotechnical investigation required.

Note:

In most cases, an initial structural assessment should first be completed in order to determine a likely foundation assessment strategy.

In keeping with the general assessment approach outlined in Figure 3.1, it may be necessary to iterate this process if subsequent findings change the earlier assumptions that inform this process.

Figure 3.3: Soil and damage investigation selection criteria for liquefaction-prone sites

Note: CGD = Canterbury Geotechnical Database

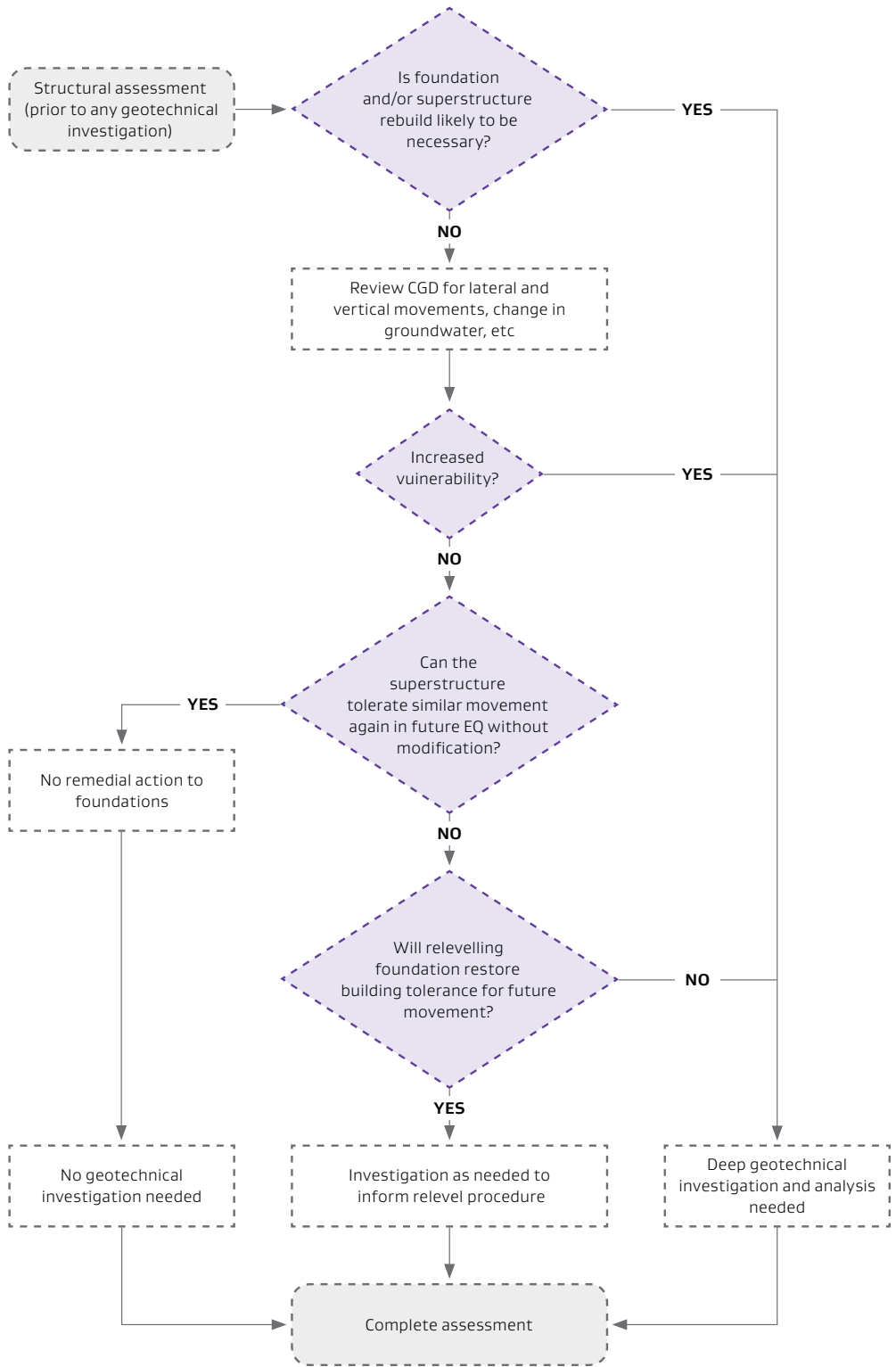

3.2.5 Investigation parameters and methodology

Where deep geotechnical investigation is to be undertaken, the following guidance applies with reference to section 13 of MBIE's Residential Guidance (noting that many industrial building sites have soil profiles equivalent to residential TC3 land):

- › the geotechnical investigations should be determined and overseen by a CPEng Geotechnical Engineer competent in geotechnical earthquake engineering
- › industrial buildings have a wide range of plan areas and loading conditions and the number and depth of tests required will vary accordingly. The extent of testing required will be subject to the judgement of the geotechnical engineer according to the variations in soil profile found across the site and the scale and type of structure planned. The number and depth of tests needed may also be informed by the number and proximity of existing deeper information in the area available on the Canterbury Geotechnical Database
- › the depth of testing is subject to the discretion of the geotechnical engineer involved. In general, a depth of 15m will encompass the extent of the most damaging liquefaction, however with the larger building size and generally higher building loads, it may be prudent for most industrial buildings to extend some tests to greater depths to be able to properly assess a piled foundation option. The early termination of tests, cone penetration tests (CPT) in particular, may result in the loss of potentially useful information regarding possible pile founding depths, ground improvement options, overall site settlements and general site characterisation
- › CPT tests are usually suitable for the type of site being considered and are likely to be the predominant investigation test, and are preferred to borehole standard penetration tests (SPTs) in determining liquefaction susceptibility. CPT equipment should be calibrated, and procedures carried out to ASTM D5778-12. Where SPTs are used, it is important that the equipment is properly energy rated so that an appropriate energy ratio can be used to correct the SPT 'N' values
- › the MBIE Residential Guidance requires a standard liquefaction analysis methodology in order to obtain liquefaction settlement index numbers related to the Technical Category (TC) classes. Non-residential land has not been zoned in TC classes, and equivalent foundation options have not been developed for industrial buildings. Consequently, there is not the same need to adopt a standard analysis methodology. However, there is merit in using the standard method as it then links the site into the broad damage categories of the MBIE Residential Guidance and may provide useful parallels to expected foundation performance and foundation systems of residential buildings. The recommended method is to use report UCD/GCM-14/01 "CPT and SPT Based Liquefaction Triggering Procedures" by R Boulanger and I Idriss (2014) (available at <http://cgm.engr.ucdavis.edu/library/reports/>) ensuring that the following requirements are met:
 - at SLS for sites in the Canterbury earthquake region, both the M7.5 / 0.13g and a M6 / 0.19g design case should be analysed (and the highest calculated total volumetric strain from either scenario adopted)
 - at ULS it may be sufficient to simply analyse the M7.5 / 0.35g case for sites in the Canterbury earthquake region.

If fines contents are being derived from CPT data, the new FC / I_c relationship in the 2014 methodology should be adopted. A CFC fitting parameter of 0.0 should be used, unless appropriate lab data or other evidence supports a different value. For example, Robinson et al (2013) suggests a value of $CFC = -0.07$ could be adopted for liquefiable soils along the Avon River. Refer to 'Clarifications and Updates to the Guidance', Issue 7 October 2014, Question and Answer 50 and 51 for more detail. Only data obtained directly from CPT or SPT measurements should be used in carrying out liquefaction assessments

- › ground motion inputs for SLS and ULS liquefaction analysis for deep soft soil (Class D), for IL2 building sites are:
 - SLS 0.13g at M 7.5, and 0.19g at M6
 - ULS 0.35g at M7.5

Further information on these peak ground accelerations is found in Appendix C2 of the MBIE Residential Guidance and in Question and Answer 50.

3.3 Structural considerations

Although every building should be considered on its own merits, there are some trends in performance that have been observed, many of which relate to particular structural characteristics of the buildings.

The following is a summary list of issues that may be considered, some of which are addressed in more detail in the following topics:

- › differential settlement - local versus global settlement:
 - effect of significant variations in bearing pressure under foundations
 - flexibility and effect of differential settlements
 - panel connection distress.
- › roof bracing issues (or lack of roof bracing)
- › stiffness compatibility issues
- › non-ductile or brittle behaviour
- › large building effects (pre-existing issues with regard to temperature or shrinkage movement)
- › load path issues
- › poor distribution of mass/strength
- › reduced functionality of floor and foundation systems.

3.3.1 Primary structure

The primary structural systems of industrial buildings have generally performed adequately. As single storey structures, the seismic actions are generally relatively low and frequently earthquake loading is not the governing load case. This has been an important factor in many older structures that may not have been designed for seismic load. Even where the direct seismic loads have significantly exceeded the original design load, the buildings have had sufficient reserve capacity. In addition, the ductility demand is usually low.

Hence, many of the problems that have been observed with the primary structure are the result of differential settlement and compatibility issues, rather than direct shaking related outcomes.

A detailed methodology for the assessment of damage to the primary structure is presented in section 3.4 of this document.

Tension-only bracing is an exception where the actual ductility demand may have significantly exceeded the system capacity, particularly in older buildings. In such cases, the bracing is frequently poorly detailed by current standards. The outcomes in such cases may have been fractured bracing or connections.

Tension-only systems may also have performed poorly where there has been differential settlement, as this adds significantly to the ductility demand. This should be given careful consideration when repairing these systems, noting that it is not always easy to add ductility, and that differential settlement will generally result in the bracing in one direction going slack while the other direction ductility demand may be exceeded.

Unless specifically detailed for the effects of overstrength actions, tension-only bracing should be treated as elastic or nominally ductile for the purposes of assessment. Care should be taken to include the C_s factor in assessing demand, in accordance with NZS 3404.

3.3.2 Differential settlement effects

Where the strength and stiffness of the wall and foundation assembly are high enough, the soil deformation may be normalised – that is, the resulting differential settlement will have resulted in a constant slope along the line of the wall(s). However, where there are significant strength and/or stiffness changes in the wall and foundation assembly, the differential settlement may be concentrated in a discrete location, resulting in damage to adjacent elements of the structure. This is illustrated in Figure 3.4, particularly items b, c, d, and e.

Figure 3.4: Influence of wall and foundation stiffness on settlement



a) Wall and foundation stiffness and connection strength result in constant slope.



b) Strength and stiffness discontinuity due to opening results in abrupt slope change.



c) Change in slope may indicate overstressing of panel connections.



d) Change in slope may indicate overstressing of panel connections.



e) Offset may indicate overstressing of panel connections.

A similar outcome may also result when panel connections fail or are highly flexible. Refer to section 3.3.4 of this document for more detail.

3.3.3 Roof bracing

3.3.3.1 Bracing performance

Roof bracing in industrial buildings generally consists of steel angle or rod diagonal braces often with double purlins or heavier steel elements to act as collectors and to resist the increased loads imparted by the bracing. The location of braced bays is variable, but they are often located in the end bays, adjacent to the end walls, where most of the wind or seismic load is applied.

Roof bracing (and in some cases diagonal tension bracing in walls) has failed due to earthquake action in a number of cases. The requirements for bracing and bracing connections in the pre-1976 New Zealand Standards did not reflect the demand on these systems. Many bracing elements have simply been overwhelmed due to the extremely high demand caused by shaking in excess of the design load. However, there are cases of premature failure where ductility has been assumed in excess of what the brace or its connections can reasonably tolerate.

It is also possible, in some cases, that excessive demand has resulted from differential settlement where the strength of the brace or its connections has not been enough to impose a uniform displacement on the foundations.

The implications of bracing failure have rarely resulted in a life safety hazard, as these systems are typically located in single storey structures with low gravity loads. However assessors should be careful to consider whether the failure results from direct shaking or is settlement induced. If the former, simple comparable replacement of the brace may be appropriate but if the failure results from differential settlement effects, a different approach may be required.

More commonly, the bracing may have yielded or loosened, resulting in increasing drifts and/or differential settlement. This may result in damage to non-structural elements but may also result in alternative load paths developing, often in non-structural elements (such as lightweight cladding systems) or in weak axis bending and shear of portal frames. The performance of those latter systems may have been compromised by the distortions imposed or the reduction in support provided.

3.3.3.2 Absent bracing

A number of industrial buildings have no roof bracing, by design. In these cases, lateral stability is generally provided by cantilevered columns and walls in one or more directions.

Observed issues with industrial buildings constructed to the 'no roof bracing' design approach include:

- › where the foundations are on soft or liquefiable ground, excessive deflections of the cantilevering columns may have resulted in significantly greater displacements in the superstructure than the designer anticipated, resulting in increased damage to other elements supported by these elements
- › although the designated systems may have sufficient strength, the flexibility of the system may result in displacement that exceeds the deformation capacity of the roof cladding. Consequently, the roofing has acted as a structural diaphragm and taken the initial load, resulting in overstressed connections and other non-structural damage, typically manifesting as tearing of the sheeting.

3.3.4 Out-of-plane failures

Failure under face loading of concrete panels, concrete block walls, or unreinforced masonry walls has often been observed. This may have resulted either from the level of shaking being higher than expected, or from under-design of the wall elements. In either case, the matters for consideration now include:

- › the ongoing ability of the panel to continue to resist face loads in the future
- › the extent to which the panels support gravity loads at high level beyond their own self weight
- › the required repairs to the panel to restore structural integrity.

It is important to determine the type and form of reinforcement in the panel, particularly at connections. This may vary according to the age and construction type.

In areas where panels have moved out-of-plane, the adequacy of the roof supporting members to provide continual gravity load support should be checked.

3.3.4.1 Reinforced concrete (RC) panels

Reinforced concrete (RC) panels are probably the most common form of exterior wall on industrial buildings. They often are required to resist in-plane loads as well as to act as cladding. Since the 1950s, RC walls have often been constructed using tilt up techniques, but have also been cast off-site and trucked to site for erection using similar methods.

A feature of many RC walls in Canterbury has been the use of cold-drawn welded wire mesh as reinforcement, apparently in some cases right up to the time of the earthquakes, notwithstanding limitations contained in the materials design standard, NZS 3101:2006 clause 5.3.2.6. This steel is generally not capable of developing any significant strain beyond yield. Ductile mesh has only been available in the New Zealand market since 2011. Furthermore, this reinforcement is often relatively light, reflecting the low demand anticipated at the time of design, which was often governed by lifting considerations for tilt panels.

As the assessed demand under face loading may now be significantly greater than when the panel was designed, it is likely that some panels have inadequate reinforcement to resist even 33% of current code demand (in order to satisfy earthquake-prone building criteria). In these cases, it is also possible that the flexural capacity of the panel reinforcement may be less than the cracking moment of the panels.

Because the mesh is brittle, the implication of almost any level of inelastic displacement of the panel is that the mesh may fracture. Fracture or necking of mesh has been observed in other situations at crack widths of as little as 2mm.

This is dependent on the bond of the mesh to the concrete but even though the mesh is not deformed, it is not safe to rely on the bond being broken over the unanchored mesh wire length, typically 150mm between cross wires.

Panel aspect ratios have been progressively reduced over the years as construction methods and code changes have enabled thinner panels. A study in 2005⁸ quoted H/t ratios in excess of 70. Although these walls have apparently performed adequately for in-plane loading, very high deflections under face loading may result in significant P- δ effects, which may not have been allowed for in design. Some cases of excessive permanent deflections have been observed.

8 Poole, R.A. (2005). Report to Department of Building and Housing – Review of Design and Construction of Slender Precast Walls. Wellington, New Zealand: Department of Building and Housing.

Assessment and repair of panel buildings has been previously addressed in more detail in section 9C of the Detailed Engineering Evaluation Technical Guidance⁹. This section is reproduced in Appendix C5 of this document.

3.3.4.2 Concrete block walls

Major factors influencing the behaviour of concrete block walls are the extent of filling of the walls and the distribution of reinforcement in the walls. It can also be important to separate the design intent from the actual work as performed on site, as there have been many observed instances of the as-built construction not matching the available drawings.

Older concrete block construction was frequently unfilled or only partially filled. Use of bond beams only at the tops of unfilled block walls in these older construction examples is common. Partially filled walls are also common, with the filled cores being lightly reinforced, extending to bond beams. The bond beams are generally at the top of the wall, but sometimes also at intermediate levels. There were several observed instances of failed walls showing up construction defects whereby the filling and the reinforcement were in different cores.

Aspect ratios of block walls are generally not as high as for thin precast concrete wall panels and so additional P- δ effects are not generally a significant concern in concrete block walls.

3.3.4.3 Unreinforced masonry walls

Seismic behaviour of unreinforced masonry under face loading is generally poor. Unless there is sufficient confinement, masonry tends to topple at relatively low loads, particularly under cyclic loading where the mortar cracks and tensile capacity reduces to zero. This is more pronounced in light axial load situations, eg in the uppermost storeys of buildings or in infill walls where the frame carries the weight of the infill above.

Most unreinforced masonry walls in industrial buildings are brick, with larger structures often featuring infill panels within concrete frames. The degree of confinement offered by the concrete may provide a significant strengthening effect for out-of-plane actions where there is direct contact. However, this may also cause a short column effect in the frame under in-plane action. Guidance is given for analysing this in the NZSEE Guidelines¹⁰.

3.3.5 Assessing connections

Careful inspection for damage to precast panel connections is required. Typically damage is concentrated at connections and some connections may have been compromised by the earthquakes and require replacement.

All panel connections require consideration but, in general, will fall into two categories:

1. primary panel connections
2. other panel connections.

Aspects of each are discussed in the following topics.

9 MBIE, Engineering Advisory Group. (2006). Draft Guidance on Detailed Engineering Evaluation of Earthquake Affected Non-residential Buildings in Canterbury, Part 3 Technical Guidance. Retrieved from www.sesoc.org.nz/images/DEE_Part%203_Technical_Guide_S8_R4.pdf

10 New Zealand Society for Earthquake Engineering Inc. (2006). Assessment and Improvement of the Structural Performance of Buildings in Earthquakes. Retrieved from [www.nzsee.org.nz/db/PUBS/2006AISBEGUIDELINESCorr3_\(incl_2014_updates\).pdf](http://www.nzsee.org.nz/db/PUBS/2006AISBEGUIDELINESCorr3_(incl_2014_updates).pdf)

3.3.5.1 Primary panel connections

The primary panel connections are vulnerable in all cases where there are stiff panels that form part or all of the primary lateral load resisting mechanism and where discrete connections are transferring loads (as opposed to other jointing systems that result in fully integrated walls or frames). In this case, the distinction is twofold:

1. the connections may become the focus of imposed displacements because of the relative in-plane size and stiffness of the panel elements
2. the connection itself may be the determining factor in the capacity of the overall lateral load resisting system.

For industrial buildings, this type of connection mainly relates to precast concrete panels, but the same considerations may apply to other connections between primary elements. The connections may be either brittle or flexible/ductile and this may have considerable influence on the behaviour of the building.

The building's age may give some clues as to the likely type and format of connections, but there are many variations in design approaches. Consequently it is recommended that all panel connections are reviewed carefully, regardless of building age.

It is critical that the influence of 'locked-in' stresses that exist due to the effects of aggregated earthquake deformation is considered. This should be addressed in two ways:

1. Direct observation: a brittle connection that shows signs of cracking may be at the limits of its ability to resist further loads. Conversely a ductile or flexible connection that is only moderately deformed (say less than 50% of its potential movement capacity) may be considered to have adequate capacity to resist future earthquake displacements.
2. Analysis: the building analysis should allow for the effects of deformation including consideration of the connection ductility. That is, if the connections are brittle, the building should have been analysed as a brittle building.

The damage threshold indicators in section 3.4 of this document may give further guidance, noting that such cases should be assumed to be non-ductile for this assessment.

Many tilt panel structures in Canterbury use weld plate connectors. These are often brittle, and generally have no allowance for shrinkage over the structure's length. The concrete around the connections is often damaged by expansion due to the heat build-up from welding. Where multi-bay structures contain panels over a significant length, it was common even before the earthquakes to see cracked connections at reasonably frequent intervals, as a result of shrinkage or thermal movements. These 'prior failed' connections may have had an influence on the structure's behaviour as a whole, either by acting as stress relief points, focusing movement into a single location, or by reducing overall capacity. In such cases, the building's capacity with and without the weld plate connection may need to be separately considered.

Bolted connections offer more ductility, provided that the anchorage of the connection into the panels is fully developed. Cast-in sockets or similar, with the anchor rods that are typically (but not always) included, are not generally capable of preventing a crack occurring – instead they offer a back-up to prevent a full pull-out failure. The success or otherwise of this detail depends on the reinforcement detailing within the panel around the insert, requiring adequate continuous trimmers at panel edges to prevent the connection failing completely.

Another common practice in older tilt panel buildings is to have bolted connections into proprietary socket inserts welded to anchor bars. Many of these inserts were manufactured from easy-cutting steel that had a high content of alloy materials making it unsuitable for welding. These are likely to be brittle.

The assembly's ductility should be considered carefully. Although steel is a ductile material, the way that it is detailed determines the connection ductility. For example, in a panel to floor connection, if a hooked bar is inadequately anchored, it will cause a cone pull-out, well before the bar will yield at the panel-floor interface.

The location of panel fixings with respect to likely panel cracks should also be considered. For example, a common base detail in more recent years relies on cantilever action being achieved with cast-in fixings at the base (refer to Figure 3.5). In the event of a crack developing, the anchor has its capacity instantly reduced and cannot be relied on to intercept the compression struts required to complete the load path.

Figure 3.5: Panel base fixing detail illustrating potential crack locations

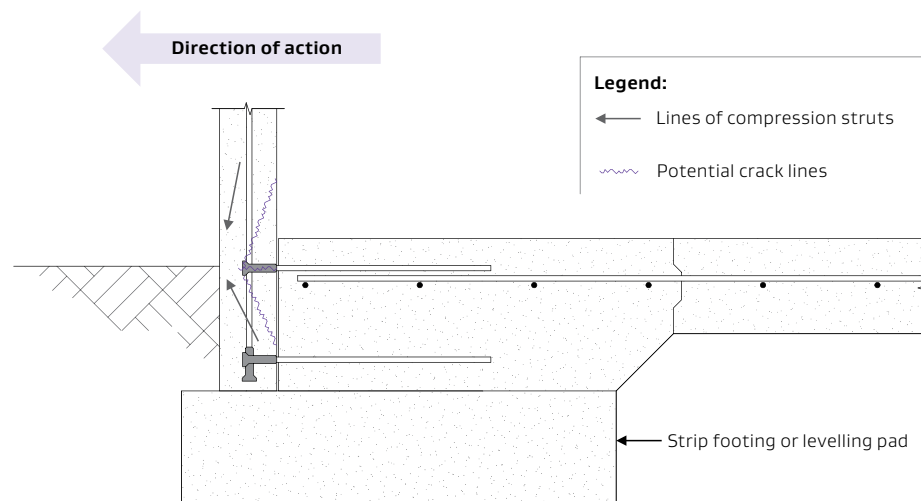

In order to identify issues with connections below ground level, localised external excavation and/or partial slab removal may be required.

Consideration also needs to be given to the behaviour of panel connections in fire, according to factors such as the proximity to the boundary and the spread of fire requirements to adjacent structures.

3.3.5.2 Other panel connections

Other connections typically involve the restraint of panels for face loading and do not determine the behaviour and capacity of the primary lateral load resisting system.

All other connections should be assessed for both strength and deformation capacity. In the case of connections that have failed, it is important to consider whether the failure is simply as a result of the loads being much higher than expected, or if it is an indicator of more unsatisfactory performance or substandard construction. In the latter case, this may be an outcome of gross under-sizing of the connection, or from premature failure of other parts of the system leading to an alternative load path that over-stresses the connections.

It is therefore critical that the assessor determine which of these has happened and use this to inform the subsequent repair or replacement strategy.

3.3.6 Configuration issues

The overall configuration of any building will have a significant influence on its behaviour. Specific configuration issues are described in the following topics.

3.3.6.1 Cantilevered columns

A significant number of industrial buildings have the primary lateral load resistance supplied by cantilevered columns, with base stability being provided either from postholes, or from large pads. Where such buildings are on soft or liquefiable material, large rotations may occur at the base, imposing significant displacements and/or forces at high level. This may also result in diagonal crack patterns at end bays, where the much stiffer end wall may result in significant warping actions on the end panels, with ensuing cracking and damage. These cracks may superficially resemble settlement cracks, but this may be ruled out by completing a level survey.

Where these elements provide gravity support to roof members the connections to the roof members need to be inspected to check that the vertical support has not been compromised.

3.3.6.2 Oversize lintel panels

In many tilt panel industrial buildings, the entire perimeter wall cladding system consists of precast concrete panels, even where there are large (often multi-bay) openings in the walls. Typically this form of opening incorporates precast concrete lintel panels spanning horizontally between adjacent panels either side of the opening. This creates a stiffness incompatibility with the adjacent solid wall elements, often resulting in differential settlement being concentrated at the openings. This puts considerable further stress on the lintel panel connections at these locations, in excess of the demands resulting from shaking damage alone.

The connections to these lintel panel elements should be carefully checked, particularly where the panels are located above key egress points for the building.

3.3.6.3 End bay compatibility

Where there has been excessive movement in the portal frames adjacent to stiff end walls, there is potential for excessive damage to the cladding. Guidance is given on acceptable deflection limits in Table C1 of NZS 1170.0, relating to deflection of portals under E_s or W_s (SLS earthquake and wind actions respectively) load cases, noting that this is recommended guidance only.

3.3.6.4 Uneven mass and lateral load resistance distribution.

Several instances were observed where poor configuration of mass and lateral load resistance was a significant factor in the poor performance outcome in the earthquake. Two cases are described below:

› Example building 1

In this case, the building has a partial first floor at one end, supported in the longitudinal (Y) direction by a line of panels at each side (refer to Figure 3.6). Although there was probably sufficient in-plane capacity in the panels at each side of the building to support the additional load of the first floor and end panels, there were no (or insufficient, in either stiffness or strength) collector elements to drag the load back along the entire length of the wall. In the absence of such collector elements, there was insufficient strength and/or stiffness in the panel connections and so the front of the building separated from the remaining structure.

Figure 3.6 (a): Schematic plan layout of example building 1 featuring an incomplete load path

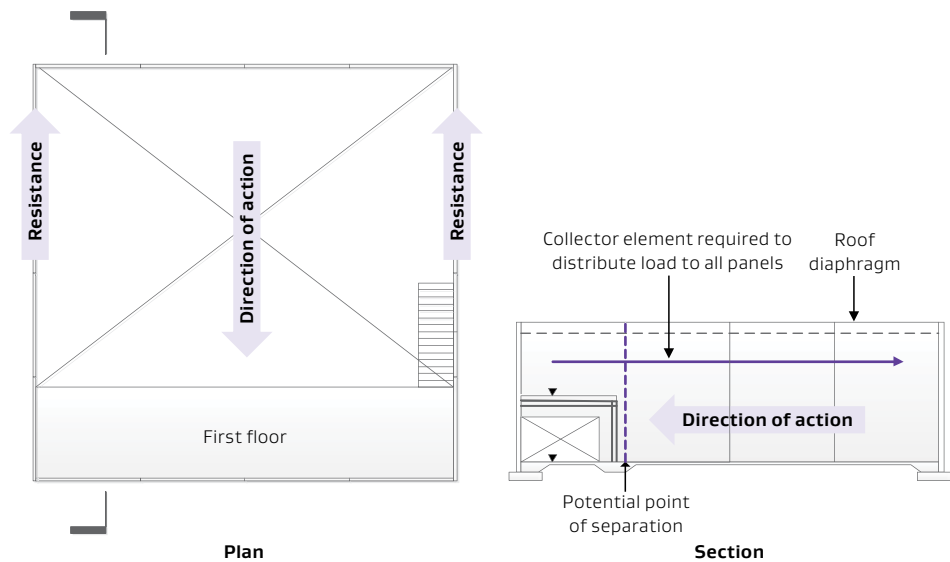

› Example building 2

Another typical example of this type of failure is in buildings with isolated areas of mezzanine floor, typically in corners of buildings, where one or two sides of the mezzanine have their lateral load resistance provided by open structural steel frames. Although the frames (shown as dotted lines) may have been designed on a tributary width basis, on the assumption of floor diaphragm flexibility, the stiffness incompatibility may result in additional seismic loads being applied to the panels, with resulting overstressing of panels or (more likely) the connections.

Figure 3.6 (b): Schematic plan layout of example building 2 incorporating a lack of symmetry

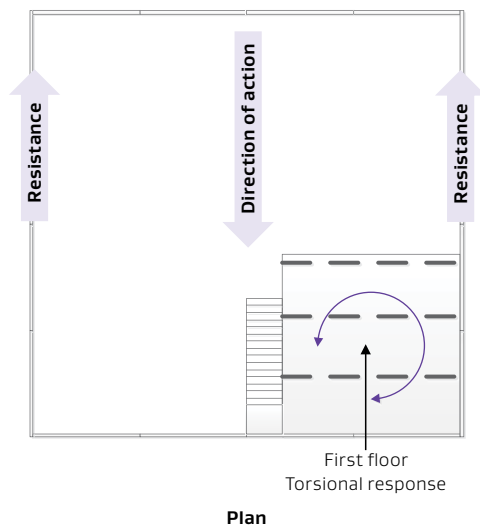

3.3.7 Slab on grade performance

The ground floors of most industrial buildings are concrete slabs on grade.

Note:

This section is not applicable to industrial buildings with suspended ground floors.

Slabs on grade are susceptible to the effects of liquefaction and differential settlement. In many cases liquefaction may have occurred at depth but has not resulted in surface expression through ejecta. In such cases, there may still be severe differential settlement at ground level. Differential settlement can also result from consolidation of soft soils without liquefaction, particularly under the action of vibration from specialised plant and equipment or heavy foundation loads. This is generally of less concern under industrial buildings, which typically do not have heavy foundation loads. Such effects should be ruled out of consideration before coming to any conclusion regarding settlement.

In assessing slabs on grade it is critical to ascertain the structural function (if any) of the slab. In some cases, the slab on grade may be required to act as a tie element across the building, or may be required to assist in providing out-of-plane stability of cantilevering walls under fire or post-fire actions.

The form of reinforcement in the slab should be determined. There are four main categories of slab reinforcement:

1. Unreinforced
2. Cold-drawn mesh reinforced
3. Ductile mild steel reinforced
4. Post-tensioned (with high-tensile steel)

Assessment of the impacts of slab movement is highly dependent on building use. Refer to section 3.4 of this document.

In areas where liquefaction has been identified, sub-floor investigation to detect voids under the slab may be appropriate to ensure uniform support is still provided for the floor. This could be by falling weight deflectometer (FWD), or ground penetrating radar (GPR).

Where possible, it is important to consider the significance of prior movement (construction tolerance and historical settlement). If it is assumed that all variation is a consequence of the earthquake sequence, the impact of the earthquake movement on the structure may be over-estimated.

3.3.8 Fire considerations

The extent to which fire needs to be considered depends on the repair or rebuild approach. This is addressed with respect to the applicable sections of the Building Act in sections 4 and 5 which follow.

It is important in the assessment phase to note information that may be required in the subsequent phases. This includes:

- › where the title boundaries may require specific fire separations to be repaired or maintained

Note:

in buildings that cross title boundaries, this may impact on internal structure as well as exterior walls.

- › the location of fire egress paths that need to be considered with respect to maintenance of the protection systems
- › where elements of vulnerable structure may adjoin egress paths or mustering points.

3.3.9 Inter-tenancy (party) walls

Inter-tenancy walls are generally performing more than one function. In addition to providing seismic load resistance, they will almost certainly have to satisfy fire (and possibly acoustic) separation requirements. Care is needed to establish if fire performance is dependent on lateral support provided by elements each side of the adjoining structure. This will apply to all walls on title boundaries even if the structure is continuous over more than one title, unless there are legal covenants in place that allow fire-rating requirements to be waived. This should be verified with the owner.

3.3.10 Underground tanks and basements

Many underground tanks and basements have floated as a consequence of liquefaction. Where these structures are under buildings or parts of buildings, this can have a significant influence on the structure above. In particular, where the underground structure is not under the entire building's footprint, increased differential settlement has often resulted. While basements are generally easy to detect, underground tanks are not always obvious. Assessors are advised to ensure that they have checked with owners for the presence of these structures before commencing work on site.

Note:

Many underground tanks have been simply abandoned over the years, rather than fully removed. If unusual ground movement is observed, the presence of abandoned tanks should be considered. This may mean that there is ground contamination, which may require special treatment if soil is to be removed from the site.

3.4 Detailed assessment approach

3.4.1 Overview

A procedure for assessing the effects of damage on industrial buildings is presented in Figure 3.7. This procedure follows a similar approach to the MBIE Residential Guidance, but is extended to cover a greater range of building and foundation configurations.

Figure 3.7: Detailed assessment process

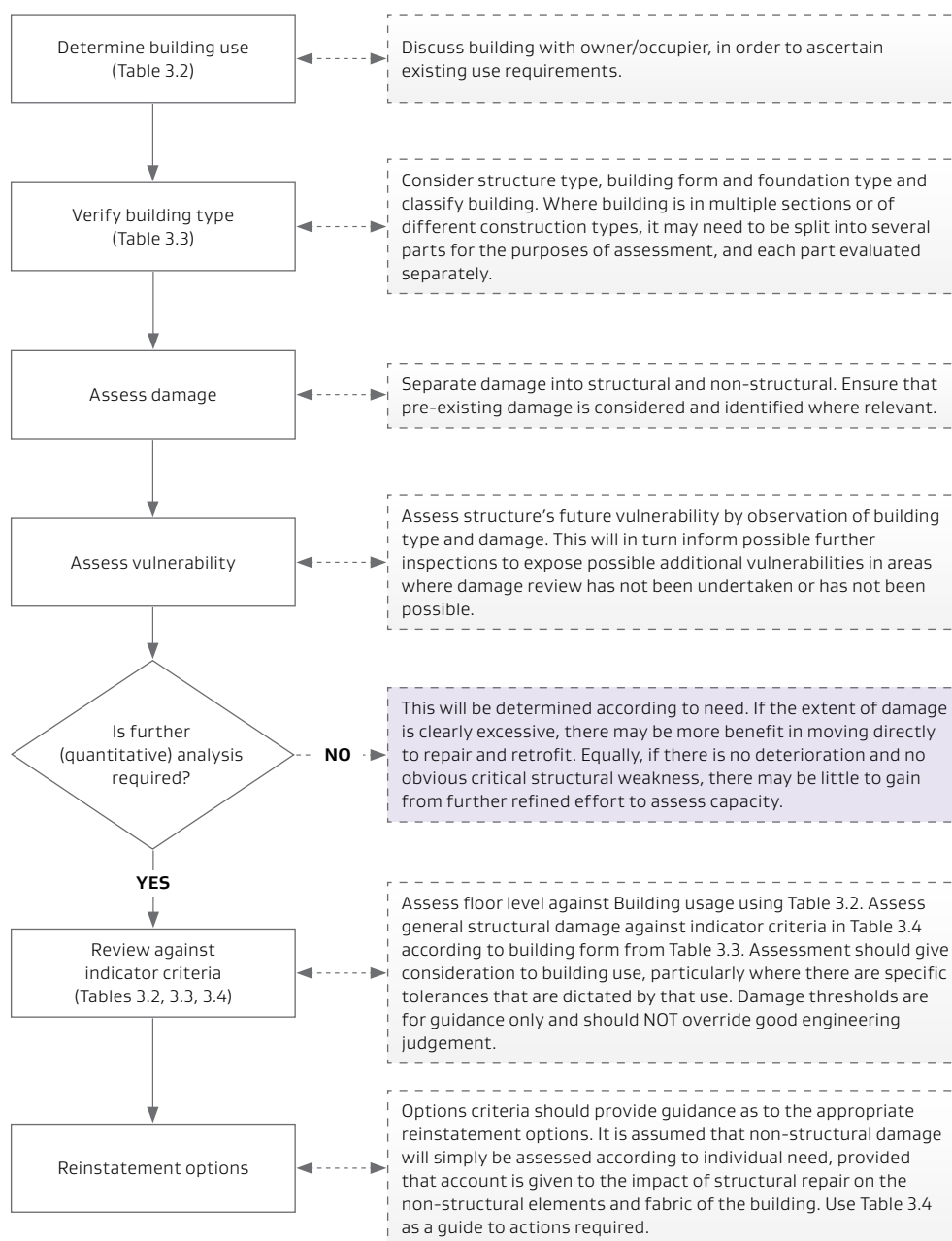

As implied above, the first part of the assessment is mainly qualitative, the second part quantitative. Quantitative assessment is not required as a matter of course – it should only be undertaken if it will add value. A quantitative evaluation may provide a more accurate assessment of the building's seismic capacity, but this may be of limited value to the owners or users, particularly if the building in question is a relatively low-risk structure. Equally, if significant repairs or retrofit are obviously required, time may be better spent considering alternatives for repair and strengthening, or replacement.

If full quantitative assessment is required, the following tables and figures provide a methodology for assessing the primary structure. It is not critical that the assessment is applied to all of the structure. Instead, it should focus on the critical elements and bypass those that are undamaged or otherwise clearly not critical to the future performance of the building.

The damage thresholds used in the qualitative assessment may also inform the development of repair and strengthening strategies. By considering the available displacement capacity of the structure, engineers can consider whether the building requires significant additional strength, stiffness or a complete alternative lateral load resisting system.

If implementing the quantitative assessment procedures, it should be noted that the connections may determine the available system ductility. This may be particularly critical in tilt panel structures with brittle connections (such as weld plate connections or bolted connections with shallow post-fixed anchors).

3.4.2 Structural assessment

There are two sets of indicator criteria provided for the structural assessment. The first (in Table 3.2) considers the impact of level variations on the ground floor, related to the building use, and is for general guidance. If the indicator criteria are exceeded, it does not automatically necessitate removal of all or part of the slab. However, further more detailed evaluation may be required, which should consider the specific needs of the user. In some situations, greater level variations may be acceptable, provided that there are no operational safety-related problems.

The second set of indicator criteria (in Table 3.4) provides damage thresholds for the assessment of the effects of imposed displacements on the superstructure and is for general guidance. As an alternative to the recommended actions, if the indicator criteria for a particular element are exceeded, further more detailed evaluation may be completed using established methods (such as the NZSEE Guidelines¹¹), noting that the evaluation of drift or settlement for a future event should include an allowance for the displacement that has already occurred.

3.4.2.1 Floor level assessment

The acceptability of differential settlements in the ground floor of industrial buildings will be influenced by the current or immediately proposed use. Many existing buildings have significant variations in floor level, and yet are used successfully for many industrial uses. Each situation should be assessed on the basis of health and safety and functionality.

.....
¹¹ New Zealand Society for Earthquake Engineering Inc. (2014). Assessment and Improvement of the Structural Performance of Buildings in Earthquakes. Retrieved from [www.nzsee.org.nz/db/PUBS/2006AISBEGUIDELINESCorr3_\(incl_2014_updates\).pdf](http://www.nzsee.org.nz/db/PUBS/2006AISBEGUIDELINESCorr3_(incl_2014_updates).pdf)

The floor level and slope criteria presented in Table 3.2 are for general guidance only. If criteria are exceeded, it may be possible to reconsider use of the affected areas of the building, or whether the specific usage of the building may allow wider tolerances. If this is not possible, releveling or rebuilding of affected areas may be necessary. Separation of the structural and usage functions of the ground floor slab may be considered, with reference to sections 4.4.1 and 5.3.2 of this document.

3.4.2.2 Superstructure assessment

While the floor indicator criteria are based on building use, Table 3.3 takes an engineering view in order to highlight the differences in treatment that arise for ductile and non-ductile structures of different structural form and behaviour.

Occasionally there will be circumstances where the damage thresholds selected from Table 3.4 are inappropriate because the building has historically functioned with greater levels of deformation not related to earthquake damage. Special attention in these circumstances is required to determine whether the most recent deformations take the building into an unstable state.

Additional indicator criteria for wall and frame systems are provided in Figures 3.8 and 3.9 respectively.

Table 3.2: Usage dependent floor level indicator criteria

Usage category/Characteristics	Description	Criteria for overall building	Criteria for affected area (refer to note 3)
1 Low-level storage (refer to note 1) (<5m) Industrial factory spaces Vehicle storage	Higher variation in floor levels tolerable without compromising the functionality of the space	Refer to note 1	Maximum level difference less than 150mm Maximum floor gradient due to differential settlement less than 1 in 100
2 Warehousing with medium height storage (5-8m) Industrial or factory spaces requiring transportation of materials and equipment on hand-operated wheeled equipment	Moderate variations in floor levels tolerable without compromising the functionality of the space	Refer to note 1	Maximum level difference less than 100mm Maximum floor gradient due to differential settlement less than 1 in 150
3 Warehousing with high stacking and/or high floor loads (>8m) Uses involving precise equipment that require level floors	Low variations in floor levels tolerable for these buildings	To meet the specific requirements of the current usage/occupant	

Explanatory notes for Table 3.2

1. In addition to the level difference criteria for the affected area(s), the planar tilt of a building needs to be considered in terms of both the structural implications and other functional (amenity) implications. Refer to section 3.1.5.
2. Non-structural criteria are not included and require separate consideration in terms of the effect of settlement on performance and overall functionality.
3. These criteria define damage threshold 1 (DT1) for building usage in Table 3.4.

Table 3.3: Structure and foundation categorisation

This table categorises different superstructure types and the different foundation types. It is intended to inform Table 3.4.

Foundation types	Concrete/Masonry						Steel or structural timber	
	Structure Category	3	4	5	6	7	8	9
Type A4: Timber floor with piles	URM ¹	Non-ductile walls ²	Ductile walls ($\mu > 2$) ³	Non-ductile frames ²	Ductile frames ($\mu > 2$) ³	Braced frames	Moment frames	
Type B4: Timber floor with perimeter concrete beam	Sometimes applicable – refer to the MBIE Residential Guidance for further assessment	Generally not applicable for these foundation types						
Type C4: Slab on grade								
Type D: Slab on grade not integral with separate pads or strip footings under walls/frame	Da	Da	Db	Da	Db	Db	Db	
Type E: Raft foundation or slab on grade integral with pad or strip footings	Ea	Ea	Eb	Ea	Eb	Eb	Eb	
Type F: Deep piles supporting foundations only (ie floating floor)	Fa	Fa	Fb	Fa	Fb	Fb	Fb	
Type G: Deep piles supporting foundations and floor	Ga	Ga	Gb	Ga	Gb	Gb	Gb	

Explanatory notes for Table 3.3:

- 1 Lower case 'categorisation' postscripts, eg 'a' or 'b', designate the assumed ductility and/or robustness of the structure category referred to, ie 'a' non-ductile behaviour, and 'b' implies some (albeit nominal) level of ductile behaviour.
- 2 Foundation types continue utilising the categorisation used in the MBIE Residential Guidance (Types A, B and C) with others added that are more normally associated with industrial buildings (D to G).
- 3 Treat all URMs with the same level of caution, whether strengthened or not, unless strengthening consists of a completely separate lateral load resisting system.
- 4 Non-ductile concrete includes all concrete block and all pre-1965 reinforced concrete buildings, unless structural drawings are available and a level of ductility of two or more can be demonstrated by specific analysis. This category also includes pre-cast concrete wall panel systems with non-ductile connections.
- 5 Includes pre-cast concrete wall panel systems with ductile connections, provided that connections can be demonstrated by analysis either to have sufficient clearance for full inter-storey drift, or have a ductile mechanism protecting any non-ductile failure.

**Table 3.4: Indicator criteria for damage assessment to superstructure
(Table 3.4 extends over two pages: 3.28 and 3.29)**

Refer to section 3.5, Example using assessment criteria, to assist in using this table.

	Damage threshold 1 (DT1)
For building usage (normally related to out of level floors)	Refer to floor indicator criteria provided in Table 3.2.
For structural systems	<p>Applies to Da and Ea (from Table 3.3)</p> <p>The maximum change in slope along the line of any structural wall, between any two points >2m apart is $\phi < 0.2\%$ (1 in 500) [B1051.001], (refer Figure 3.8a) or</p> <p>The maximum vertical offset of any column from a line drawn between the columns either side is $\phi < 0.42\%$ (1 in 240 or 25mm in 6m) (refer Figure 3.9a) [settlement].</p> <p>Applies to Db and Eb</p> <p>The maximum change in slope along the line of any structural wall, between any two points >2m apart is $< 0.4\%$ (1 in 250) [B1044.091], (Figure 3.8a) or</p> <p>The maximum vertical offset of any column from a line drawn between the columns either side is $< 0.8\%$ (1 in 125 or approx 50mm in 6m) (refer Figure 3.9a) [B1041.021].</p> <p>Applies to Fa and Ga</p> <p>The maximum change in slope along the line of any structural wall, between any two points > 2 m apart is $\phi < 0.2\%$ (1 in 500) [B1051.001], (refer Figure 3.8a) or</p> <p>The maximum vertical offset of any column from a line drawn between the columns either side is $\phi < 0.42\%$ (1 in 240 or 25mm in 6m) (refer Figure 3.9a) [settlement], and</p> <p>Piles must be undamaged at the pile/pile cap interface. Pile should not exceed Damage State 1 (minor cracking, repairable by epoxy). Moment-curvature analysis may be required to demonstrate sufficient pile displacement capacity with reduced lateral support from ground.</p> <p>Applies to Fb and Gb</p> <p>The maximum change in slope along the line of any structural wall, between any two points >2m apart is $< 0.4\%$ (1 in 250) [B1044.091], (refer Figure 3.8a) or</p> <p>The maximum vertical offset of any column from a line drawn between the columns either side is $< 0.8\%$ (1 in 125 or approx 50mm in 6m) (refer Figure 3.9a) [B1041.021]], and</p> <p>Piles must be undamaged at the pile/pile cap interface. Pile should not exceed Damage State 1 (minor cracking, repairable by epoxy). Moment-curvature analysis may be required to demonstrate sufficient pile displacement capacity with reduced lateral support from ground.</p>
For non-structural	<p>Ponding or fall generally away from downpipes.</p> <p>Falls in floors away from surface drainage.</p> <p>Subfloor services are functioning.</p>

Explanatory note for Table 3.4

The square bracket numbers in the form [Bxxx.xxx] are Structural Fragility classifications from Seismic Performance Assessment of Buildings, Volume 2 – Implementation Guide, FEMA P-58-2 / September 2012. Retrieved from www.fema.gov/media-library-data/1396495019848-0c9252aac91dd1854dc378feb9e69216/FEMAP-58_Volume2_508.pdf

Action required if >DT1	Damage threshold 2 (DT2)	Action required if >DT2
<p>Re-level or repair affected parts of building. May be restricted to slab only if structural systems are unaffected.</p>		
<p>Applies to Da, Ea, and Eb Re-level of structure or affected parts of structure. May not require re-level of ground floor slab, if usage criteria are not exceeded.</p> <p>Applies to Db Re-level of structure or affected parts of structure to within tolerances. May not require re-level of ground floor slab, according to overall criteria.</p> <p>Applies to Fa, Fb, Ga, and Gb Re-level of structure or affected parts of structure to within tolerances. Retention of piles may be acceptable if piles undamaged.</p>	<p>Applies to Da, Ea, Fa, and Ga The maximum change in slope along the line of any structural wall, between any two points >2m apart is $\phi < 0.33\%$ (1 in 300) (Figure 3.8b) [B1051.001], or The maximum vertical offset of any column from a line drawn between the columns either side is $\phi < 0.8\%$ (1 in 120 or approx 50mm in 6 m) (refer Figure 3.9b). [1.5$\times\phi$ y].</p> <p>Applies to Db, Eb, Fb, and Gb The maximum change in slope along the line of any structural wall, between any two points >2m apart is <1.2% (1 in 80) (Figure 3.8b) [B1044.091], or The maximum vertical offset of any column from a line drawn between the columns either side is <1.2% (less than 1 in 80 or approx 75mm in 6m) (refer Figure 3.9b). [2$\times\phi$ y].</p>	<p>Applies to all building types Repair or rebuild of affected structural elements and foundations. May require new floor, to extent that floor must be removed to facilitate structure rebuild, or to satisfy other criteria.</p>
<p>Some localised releveling may be required to reinstate floor or roof falls. This may also be accomplished with selected jacking and packing of super-structure elements, or by removing and refixing elements such as guttering.</p>	<p>Generally as DT1, but subfloor services are not functioning</p>	<p>If there is irreparable damage to buried services within the building footprint, then replacement of affected services may require removal of the slab for access to carry out replacement, or alternatively, services may be rerouted above the slab to the perimeter. Flexible connections should be installed when replacement services are introduced, provided there are no other detrimental effects.</p>

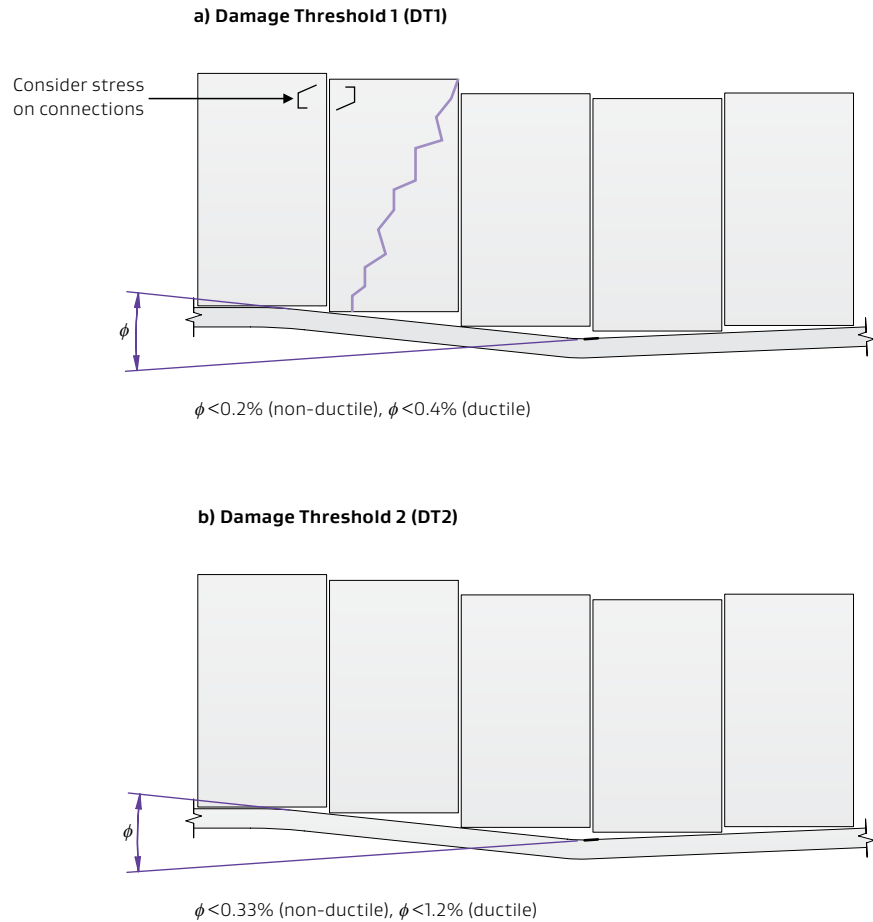
Figure 3.8: Indicator criteria for wall systems**Table 3.5: Inferred level differential over 6m for wall system from Figures 3.8(a) and 3.8(b) above**

Wall structure category	Applicable damage threshold (DT)			
	DT1		DT2	
	Angular rotation	Level differential (mm)	Angular rotation	Level differential (mm)
Non-ductile	0.2%	12mm	0.33%	20mm
Ductile ($\mu > 2$)	0.4%	24mm	1.2%	72mm

Figure 3.9: Indicator criteria for frame systems

a) Damage Threshold 1 (DT1)

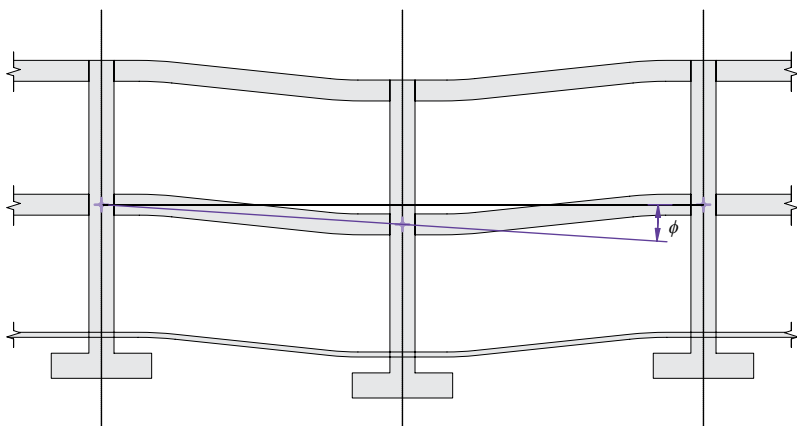

$\phi < 0.42\%$ (non-ductile), $\phi < 0.8\%$ (ductile)

b) Damage Threshold 2 (DT2)

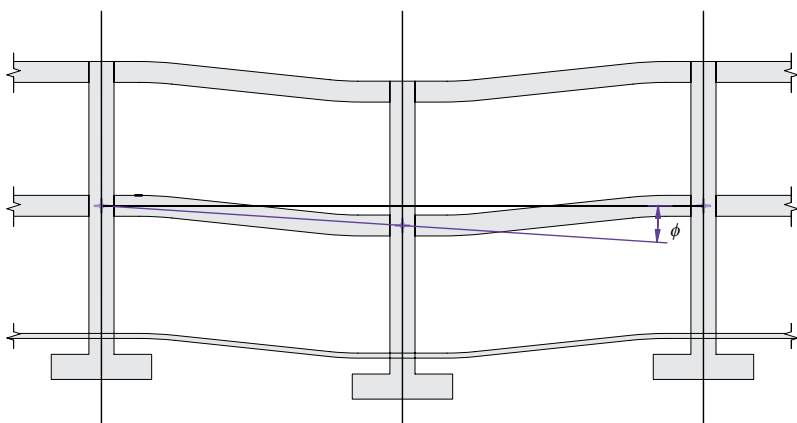

$\phi < 0.8\%$ (non-ductile), $\phi < 1.2\%$ (ductile)

Table 3.6: Inferred level differential over 6m for frame system from 3.9(a) and 3.9(b) above

Wall structure category	Applicable damage threshold (DT)			
	DT1		DT2	
	Angular rotation	Level differential (mm)	Angular rotation	Level differential (mm)
Non-ductile	0.42%	25mm*	0.8%	48mm
Ductile ($\mu > 2$)	0.8%	48mm	1.2%	72mm

* Corresponds to B1/VM4 Appendix B

3.5 Example using assessment criteria

Consider a standard tilt panel warehouse structure, with portal frames in the transverse direction, supported by the panels themselves in the longitudinal direction. Refer to Figure 3.10.

The building has suffered maximum differential settlement in the order of 150mm, with localised floor slopes of 1 in 150.

The building is used for storage, with racks of up to 6m.

Figure 3.10: Example building

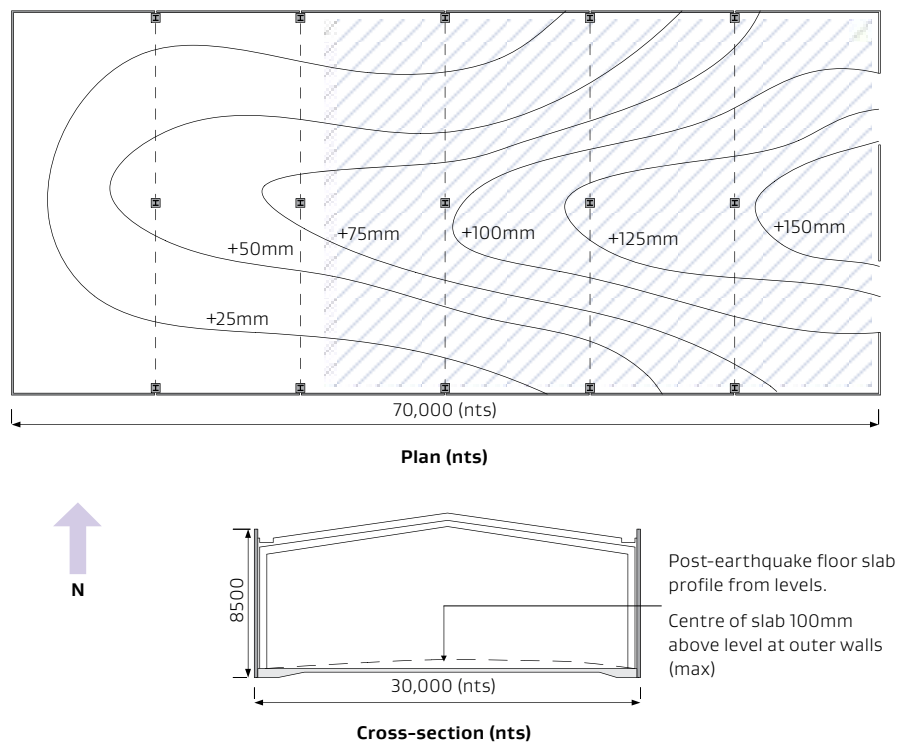

The building has medium-height storage, refer Table 3.2. The worst case slope is from a fall of 100mm in approximately 10m, giving a slope of 1 in 100. The total fall is approximately 150mm. Therefore, both the slope criteria and total level difference criteria from Table 3.2 are exceeded, although it would fit within the broader criteria for low-level storage. Approximately two-thirds of the floor slab is affected (shaded). Options may include releveling or rebuilding this portion of the slab, or alternatively, to reduce the storage height to a level within which forklifts can safely operate in the space.

Using Table 3.3

The structure has an integral slab on grade and therefore from Table 3.3 is a Type E structure. As the walls in this case have welded (non-ductile) connections, it is Type Ea in the longitudinal direction. As the transverse frames may be considered to have ductility capacity in excess of $\mu=2$, it is Type Eb in the transverse direction, apart from the end walls, which are Type Ea to match the side walls.

Note:

If the panel connections were ductile, the building could be Type Eb in both directions.

Analysis of example using Table 3.4

For the longitudinal direction

Along the north and south walls, the building is close to level over the first 30m, from the west end, after which the falls increase up to a maximum slope of approximately 25mm over the last 9m at the east end, or 1 in 360. This change in slope exceeds the Damage Threshold (DT) 1 criteria from Table 3.4 of 1 in 500, but is less than the DT2 criteria of 1 in 300. The indicated action is to relevel the structure. Alternatively, the connections in the affected areas may be disconnected and reconnected, or replaced with ductile connections. Re-assessing against the Type Eb criteria, this then falls within the DT1 criteria of 1 in 250, which would be structurally acceptable.

For the transverse steel frames

Even though there has been a change in level of some of the portals, the base of both north and south columns are at approximately the same level. Therefore there will be little differential displacement of each of the portals. This is within the DT1 criteria for Type Eb frames so no action is required.

For the end walls

The west end is essentially level, so no action is required. The centre of the east end is approximately 60mm higher at the centre, but most of this is focussed in the openings, which have concrete lintels over. With two openings of approximately 6m width on the east end, the slope is approximately 50mm in 6m, or 1 in 120. This exceeds both the DT1 and DT2 criteria for Type Ea walls from Table 3.4 and would exceed the DT1 criterion for Type Eb walls. Therefore, if the lintel panels are repairable, the connections should be replaced by ductile connections. Refer following sections for guidance on revised connection types. If the panels are damaged, they should be replaced either with lightweight construction, or with new panels in accordance with section 4 of this document.

4. Repairs

4.1 General

The intent of this section is primarily to outline simple approaches that will encourage repair of damaged buildings in order to facilitate continuity or early resumption of use where the levels of damage are moderate. The emphasis of this guidance is to enable rather than prescribe, recognising that the technical repair aspects of damaged elements is well understood, but requires further guidance regarding regulatory aspects.

Engineers, owners, and occupiers are encouraged to discuss matters relating to risk and the potential for future damage in detail before coming to conclusions regarding a repair strategy for damaged buildings. While the cost of repairs and strengthening may be greater than desired, it is important to consider possible future damage in the context of business interruption, insurance, and investment value. In some cases, future insurability may be a significant consideration, requiring consultation with brokers.

Remedial work is not necessarily best accomplished using a direct approach of simply adding strength. It is true of most buildings, but particularly those on ground prone to liquefaction-induced movement, that the addition of resilience may often be a more effective approach. This may involve the introduction of articulation and/or the removal of isolated stiff elements.

Creative approaches to repair and strengthening that enhance the potential use of a building may also be a more effective way to encourage owners and occupiers to adopt greater levels of seismic protection. For example, it may be possible to add out-of-plane bracing to vulnerable walls by horizontal additions that provide more usable space and minimise the need for potentially disruptive internal structural alterations. In some cases it may prove more cost-effective to bypass damaged lateral load resisting elements through the addition of new systems with alternate load paths, provided that the necessary consideration is also given to other primary load cases (such as gravity and wind).

In all cases, it is critical that stiffness compatibility is considered, to ensure that the new structure effectively mitigates future damage.

The repair section of this guidance commences with the regulatory requirements for repairing buildings in section 4.2. Section 4.3 deals with the subset of repairs that involve direct substitution of parts rather than repairs that redefine structural performance. The latter is included in section 4.4. Section 4.5 addresses building elements with a particular emphasis on tilt slab and lintels. There is a brief table of common structural problems and their solutions are contained in section 4.6.

4.2 Regulatory requirements

The most relevant sections of the Building Act for repair and strengthening of existing buildings are as follows:

› **Section 17: All building work must comply with Building Code**

The new work being undertaken must comply with relevant code provisions relating to that work. For example, if a new building element is being built, say a new structural wall, then the wall itself should be detailed with ductile detailing expected within current design standards, but it won't have to be designed so that the resulting repaired building can take 100% of the lateral load demand required of a new building. The repaired building will need to be designed to be above the earthquake-prone threshold of 33% New Building Standard (NBS) and preferably significantly higher. Code clause B1 for Structure requires the new building element to have a "low probability of rupturing . . .". Providing the new element itself is not the weak link then the new element will comply with the Building Code for B1. Other code clauses such as B2 Durability for the new work will need to be complied with.

› **Section 112: Alterations to existing buildings**

This requires simply that after the alteration, the building should comply as nearly as reasonably practicable with provisions of the Building Code regarding disabled access and means of escape from fire; and otherwise to no less an extent than before the alteration. Note that section 112 relates to the situation immediately prior to the repair (alteration), not prior to the earthquake. Repairs are included in the definition of alter in section 7 of the Building Act.

› **Section 115: Code compliance requirements: change of use**

This requires that a building which is undergoing change of use may be required by the territorial authority to comply as nearly as reasonably practicable with the Building Code for a range of provisions, including structure performance, and, similarly as for section 112, continue to comply with other Building Code provisions to at least the same extent as before. This means that, where there is a change of use, there will normally need to be some level of upgrade to fire, access, structure and sanitary facilities if the existing building is less than current Building Code level, while, at the same time, the repair results in other Building Code provisions being no worse than before the repair was undertaken. Change of use is defined in the Building (Specific Systems, Change the Use, and Earthquake-prone Buildings) Regulations 2005. Essentially if there is a change in fire purpose group to all or parts of the building, then section 115 of the Building Act will apply. In the case of industrial buildings, care must be taken with respect to fire, as the fire hazard between different uses may vary considerably, resulting in a change of purpose group for only a subtle change in actual use.

› **Section 121: Meaning of dangerous building; section 122: Meaning of earthquake-prone building; and section 124: Dangerous, affected, earthquake-prone, or insanitary buildings: powers of territorial authority**

Collectively, these sections cover the definition of dangerous and earthquake-prone buildings and how they may be dealt with by the territorial authority.

The level of repair or strengthening required for a building will depend on whether sections 112, 115 or 121 are triggered.

4.2.1 Net Structural Benefit Test

As noted above, both section 112 and section 115 require that building performance after the repair shall be no worse than it was before the repair takes place. These sections also require that for certain clauses of the Building Code, the performance of the building shall be upgraded (section 112 - means of escape from fire and access and facilities for persons with disabilities; section 115 - means of escape from fire, protection of other property, sanitary facilities, structural performance, fire rating performance, and access and facilities for people with disabilities). In the majority of cases repairs to industrial buildings needed as a result of the earthquakes will be subject to section 112, meaning that the structural performance will be no worse than before the repair.

From a regulatory perspective the repair has to be considered in the context of the 'whole building'. This approach enables the repair and/or replacement of parts of the building, provided it is considered that; *the structural benefit to the whole building from the introduction of a stiffer and/or more resilient part means the structural performance of the whole building will be better than before the alteration, even though in some future events there may be a possible negative impact of the alteration on the existing structure.*

In other words while the interface between the replacement and existing parts could be adversely affected in future earthquakes, the repairs and rebuilds will comply with section 112(1) (b) of the Building Act if, as a result of the works, the improved structural performance of the building as a whole will be greater than the building before the alteration, notwithstanding the possible adverse local effects to the structure in a future earthquake event.

Consideration of the net structural benefit relates particularly to buildings with multiple tenancies and/or different ownership. Refer Section E of the MBIE Residential Guidance for further background.

4.2.2 Disabled access and fire provisions

The territorial authority does have the discretion under section 112(2) of the Building Act to allow the repair to take place without full Building Code compliance if the alteration would not otherwise go ahead (if full compliance was required), and there will be some improvement in means of escape or access and facilities for people with disabilities, ie the 'access provision', and that the improvement will outweigh any detriment arising as a result of not complying.

4.2.2.1 Disabled access

It is not generally considered that the access provisions will be a significant factor for most industrial buildings, provided that they are either single storey or single storey with a partial mezzanine and their occupancy will be less than 10 people (refer Building Act section 118 and Schedule 2). Where there is a requirement, some ramping may be required at ground floor levels, and bathrooms may need to be assessed, but this is not generally onerous for industrial buildings. Refer to section D1 of the Building Code for further guidance.

4.2.2.2 Fire performance

It should be noted that the section 112 requirement (to comply as nearly as is reasonably practical with the Building Code) is not across all of the fire provisions, only those relating to means of escape from fire. Spread of fire and fire protection are not required to be assessed specifically unless there is a change of use, but the alteration (or repair) should otherwise make those aspects no worse than they were before the damage. However, means of escape from fire may require spread of fire issues to be addressed alongside safe egress paths, for example in the case of concrete panels alongside a right of way, if that is part of a protected path.

For most industrial buildings, this should mean that some signage or emergency lighting upgrade may be required. However, the 'as near as reasonably practicable' test needs to be applied bearing in mind costs and benefits. The context in Canterbury is to repair buildings rather than voluntarily undertaking building work. It is not appropriate to require major emergency lighting upgrades when relatively minor structural repairs are being undertaken. Early discussion with the BCA is advised in order to clarify an acceptable level of compliance.

Involvement of, and input from, a fire engineer may be required in particular circumstances, especially in warehousing with rack storage exceeding 5m in height.

When the building work being undertaken involves connections for precast panels (either new connections for existing panels, or new connections for new panels), the performance requirements of the Building Code need to be considered in order to satisfy section 17 of the Building Act. There are three conditions that need consideration with respect to fire:

1. Normal loading condition, ie no fire.
2. During fire: Under this condition, the connections must maintain the integrity of the building envelope, to prevent spread of fire, and must prevent collapse in order to offer protection for firefighters, neighbouring property and buildings. For further guidance on the requirements during fire, refer to Acceptable Solution C/AS1 of the Building Code.
3. Post-fire: Under this condition, the panels must maintain a minimum level of support under face loads to prevent collapse under reduced loadings, refer to AS/NZS 1170.0, section 6.

The most critical issue is the type of connection being used to connect the panels, giving consideration to performance under elevated temperatures. Neither chemical anchors (which may lose integrity at temperatures in excess of 60-100°C) nor shallow anchors (as cover concrete may spall) should be considered effective under full fire conditions.

The behaviour of the panel under elevated temperature should also be accounted for. With a steep thermal gradient across the panel, the panel will hog on the fire side. If the panel has a fixed base, the high level connections should be strong enough to yield the reinforcement at the base, or the connection may fail. Conversely, in cases where the columns have been encased over all or part of the height of the wall, the columns and base connections of the panels may make the upper level panel connections redundant.

Generally, the preference will be for connections that hold the panels tight through the fire, as these will also be robust enough to achieve lateral load transfer under seismic loading conditions.

On vulnerable sites the consequences of lateral spread of 'untied' foundation elements, eg pads or pile heads, on the superstructure's integrity under ultimate limit state condition, needs to be considered as part of any hazard assessment undertaken under section 3.1.

4.2.3 Units across multiple titles

A key consideration for buildings across multiple titles is that a building is defined by the extent of the physical structure, not by the title itself. That is, if a single structure is split into contiguous multiple titles, it must still be considered as a single integrated entity with respect to the requirements of the Building Act.

Where a building has flexible diaphragms, this may only require consideration of the additional tributary width in the immediate vicinity of the boundary walls, provided that the lateral load resistance is evenly shared among the parts of the building defined by the separate titles. However, if there are rigid diaphragms or load resistance is not evenly shared, the entire building may need to be considered as one. This may require owners to cooperate fully in getting an assessment completed.

Evidence of the treatment of the whole building should accompany any building consent application.

In assessing repairs of buildings in such cases, consideration must be given to the impact of the repairs. Where the repair is a simple like-for-like repair that has no significant impact on the behaviour of the building in the immediate area of the repair, no further assessment is required.

4.2.4 Party walls

Some additional considerations apply specifically to party walls. There is an obligation on the owners of the property on either side to consider the implications of the work they propose on both existing and future configurations. There may be some legal constraints if there are specific agreements in place (for example a party wall agreement or right of support). However, the support of or by the wall should be considered both with and without the adjacent building in place.

If separating the building under consideration from the neighbouring property, the adverse effect of the separation to the adjacent building must be considered. In such cases, it is the responsibility of the party doing the work to ensure that the adjacent property is made no worse by the alteration. This may require new roof or floor to wall anchors to be provided in the other property in order to enable the separation.

By common convention, when considering party walls in buildings with flexible diaphragms, the following procedure is generally followed:

- a. for in-plane loading of party walls, the loading to the wall should be based on the worst case of the tributary width from both sides of the wall (ie both titles)
- b. for out-of-plane loading, the wall should be assessed for support from the side under consideration only, as if the building on the other side is not there (ie the other building may be demolished at some stage in the future).

Care should be taken in the case of older buildings, where one side or the other of a party wall may have been constructed at different times and/or using different structural forms. Some common features include:

- a. load transfer between titles: where there are stiffness incompatibilities between adjacent parts of the building. This should be considered carefully when designing strengthening systems
- b. disparate floor levels: it is reasonably common for buildings on opposing sides of party walls to have different floor and roof levels. Where these are significantly different, stiffness incompatibility between the two parts may be exaggerated.

Although it was reasonably common for older buildings to have some form of tie from joists into party walls, (later) infill buildings often simply had joists toothed in, with no further connection. This lack of positive tie is particularly critical for seismic performance, for either in-plane or out-of-plane actions.

4.2.5 Detailed Engineering Evaluation

Refer to Section 2.1.1 of this document for the requirements to provide the DEE report with applications for consent and the need to inform the territorial authorities once the repairs have been carried out in order that the status of the building is updated on the earthquake-prone building register.

4.3 Structural repairs using comparable limited replacement

These recommendations are provided to establish guidelines for the replacement of earthquake-damaged components to industrial buildings where the damage is limited in extent and the majority of the building has suffered little more than minor cracking.

The recommendations given relate to appropriate technical and regulatory considerations to allow comparable limited replacement of building elements. This guidance may not align with the terms and conditions of insurance policies and may only be appropriate for repair and/or replacement of uninsured or under-insured property.

Examples where this may apply include replacement of:

- › a failed or extensively damaged precast panel
- › an isolated damaged wall
- › an isolated damaged column
- › an isolated damaged beam.

4.3.1 Criteria applicable to comparable replacement

The criteria to be applied to allow replacement under these recommendations based on comparability should be limited to cases where:

- › the building element concerned is **not** critical to the building as a whole achieving compliance with the Building Code to the extent required by section 112(1)(b) of the Building Act
- › the extent of repairs is not substantial, eg in the case of a ground bearing floor slab, the replacement area not exceeding 50% of the floor area at ground floor of the building
- › the cause of the failure of the element is identified
- › repairs of damaged elements are technically possible, but it is more practical to replace (ie rebuild the element in question) subject to enhanced resilience.

Replacement based on comparability in accordance with the above criteria should not apply to building elements within:

- › buildings defined as being dangerous in terms of section 121
- › buildings defined as being earthquake-prone in terms of section 122
- › buildings defined as being insanitary in terms of section 123.

Sufficient investigation and analysis should be undertaken to reliably establish the cause of the damage in order to ensure future events do not generate the same or greater damage. Possible causes of damage may be:

- › foundation settlement
- › earthquake shaking beyond design levels
- › design deficiency
- › structural incompatibility.

4.3.2 Remedial work where foundation settlement has contributed to damage

Where foundation settlement has contributed to damage, an assessment of the condition of the existing foundation elements is required. Foundation repair or replacement should be undertaken as appropriate where the foundation is damaged. Exposure of the foundation for inspection may be necessary.

Where a building has suffered significant foundation settlement, the implications on the balance of the building need to be tracked. The superstructure will also have been displaced with resulting rotation magnifying the impact on the elevated building components.

In addition to the main structural elements, heavy wall cladding is often supported directly off the foundation. Concrete panels can either be providing direct structural support to the roof structure or are a form of cladding supported off the primary structure. In either situation, foundation movement may result in alteration of the distribution of loads, which can be critical to stability.

The condition of panel fixings should be inspected in areas likely to be highly stressed as a result of the settlements. The fixings, including the integrity of the embedment of the fixing in the panel, should be assessed for overstress that may limit the performance of the fixing in a future earthquake.

Detailing of the connections for a replacement panel where the panel fixings were damaged by foundation settlement should be enhanced to be resilient to further foundation settlement.

In these cases, precast panel fixings should be upgraded to current code requirements with connections designed to be resilient in the event of further foundation settlement.

4.3.3 Remedial work where damage is due to excessive earthquake response

Where the damage is established as not being due to a design deficiency in the building, significant foundation settlement, or structural incompatibility, a proposal for reinstatement on a comparable basis is likely to be acceptable. Where the precast panel fixings (or other primary load path connections) would not comply with the current code requirements, the fixings should be redesigned in accordance with the following table and where appropriate the detailing modified to provide improved seismic resilience.

As significant changes have occurred in the design of fixings to precast panels with the introduction of NZS 4203:1976, the fixings for replacement panels should comply with the requirements in Table 4.1.

Table 4.1: Recommended repair approach for panels and fixings

Age of building	Limited panel replacement*	Panel fixings
Unreinforced masonry buildings	Not applicable	Not applicable
Precast panel construction pre-1965	To comply NZS 1170 for strength	Upgraded to 2/3 NZS 1170
Precast panel construction 1965-1976	To comply NZS 1170 for strength	Upgraded to 2/3 NZS 1170
Precast panel construction 1976 to 2004	To comply NZS 1170 for strength	To comply NZS 1170
Precast panel construction post 2004	To comply NZS 1170	To comply NZS 1170

* Replacement of 1 or 2 panels in a larger building.

Where design deficiency has contributed to the failure (as opposed to compliance with obsolete codes) the design deficiency should be addressed as part of the repair. Providing the design deficiency is minor, replacement should proceed on a comparable basis with the design deficiency appropriately addressed and precast panel fixings upgraded as necessary to comply with the requirements in Table 4.1.

In the event that structural incompatibility has contributed to the damage, the structural incompatibility should be addressed. Providing the structural incompatibility is minor, replacement should proceed on a comparable basis with the design deficiency appropriately addressed and precast panel fixings upgraded as necessary to comply with the requirements in Table 4.1.

In some cases, there may be historical under-capacity. When repair work is undertaken, it is recommended that the owner take the opportunity to address weaknesses in the historical loadings or materials design standard.

4.3.4 Compliance

4.3.4.1 Documentation

- › Where replacement is on a comparable basis, identifying the extent of the elements to be replaced on the original plans should be sufficient.
- › Where panel fixings need to be upgraded, revised details and supporting calculations should be provided.
- › Where the work involves addressing a design deficiency or structural incompatibility, a brief report identifying the issue and the proposed method of rectifying the issue should be provided with supporting calculations.
- › Where the work involves a building that has suffered settlement, a detailed report providing levels and extent of damage together with an explanation of the proposed use and details of revised fixings should be provided with supporting calculations.

4.3.4.2 Consenting requirements

Repair work for an industrial building involving comparable limited replacement will require a building consent unless the work is exempt from the requirement in accordance with section 41 of the Building Act. Schedule 1 of the Building Act lists details of building work that does not require a building consent. Even though the work may not require a building consent, the work undertaken still needs to comply with the Building Code. For details on exemptions, refer to the MBIE guidance document [Building work that does not require a building consent \(2014\)](#).¹²

If it is proposed that the work is exempt and may be replaced or repaired on a comparable basis, it is advised to apply for an exemption under Schedule 1(2) to ensure that a record of the repairs is maintained on the territorial authority property file.

Where significant modifications are required to the original construction, a building consent is likely to be required.

In both cases a full set of documentation of the repair work should be prepared, accompanied by a Design Features Report that outlines the approaches taken and the methodologies adopted as well as the means of compliance. A model Design Features Report has been prepared by Structural Engineering Society New Zealand (SESOC) and is available for use by members. A description of the Design Features Report is also available from the MBIE website.¹³

12 Ministry of Business, Innovation and Employment. (2014). Building work that does not require a building consent, 3rd edition. Retrieved from www.dbh.govt.nz/UserFiles/File/Publications/Building/Guidance-information/pdf/building-work-consent-not-required-guidance-3rd-edition.pdf

13 Ministry of Business, Innovation and Employment. (2014). Guidance on the use of Certificates of Work, Producer Statements, and Design Features Reports by Chartered Professional Engineers under the new Restricted Building Work regime. Retrieved from www.dbh.govt.nz/UserFiles/File/Publications/Building/rbw/certificates-of-work-guidance.pdf

4.4 Major structural repairs

Where the damage suffered is more extensive and/or severe, different approaches may be required for the repairs. By contrast with local repairs being undertaken to section 4.3, such buildings generally will have exhibited unacceptable behaviour, in whole or in part, and the repair process will therefore be focussed on changing the future building behaviour in an earthquake. At the extreme, this may include total replacement of significant areas of the building.

Where sections of the building are being completely rebuilt, designers will generally have to comply in full with the Building Code and reference should be made to section 5 for further guidance.

Where the repairs are less extensive (than a full rebuild) the following matters may be considered.

4.4.1 Foundation performance

Improvement in foundation performance on liquefiable ground may be limited to simple repairs (as noted in section 4.5.1), due to the impracticality of more extensive ground improvement or upgrading under existing buildings. This results from the relatively high ratio of building plan area to foundation area. If the perimeter foundation is to have ground improvement or piling, the ground floor will generally need the same improvement, if it is integral.

The approach noted in section 5.3.2 (separation of ground floor from the foundations) may allow the upgrading to be applied only to the foundations, provided that a tie system is added which will ensure satisfactory performance of the superstructure in the event of separation or failure of the ground floor slab.

4.4.2 Superstructure performance

If a building has suffered damage that is repairable, but would be considered unacceptable if it were to happen again, or if it has suffered sufficient damage that lies within, but close to the limit of, the damage thresholds defined in section 3.4, the building may require a repair method (or strengthening) that will change the behaviour of the building, either in whole or in part.

Examples of this may include:

- › insertion of a steel braced frame to relieve load from understrength or poorly detailed concrete panels
- › retrofit of steel roof bracing in buildings that were designed with an unbraced roof
- › retrofitting steel waler elements in cracked (mesh-reinforced) wall panels to force an alternative yield pattern.

In all cases, it is important that sufficient analysis is performed to ensure that:

1. a full load path is established and maintained
2. detailing appropriate to the ductility of the new system is followed
3. stiffness compatibility is maintained with the existing building.

Although the new elements must comply with the appropriate detailing provisions of the Building Code, the overall capacity of the building need not be higher than the lesser of 34% or the capacity of the building as it was before the repair. Hence the capacity of the introduced elements may not be 100% of the code demand as if the building were to be designed as a new building, but should be 100% of the capacity required for the building to achieve the minimum overall load level prescribed by the Building Act. In this way the building will comply with section 112.

In general, the insertion of new elements requires consideration on a case-by-case basis. As noted in section 4.1, creative approaches may be possible to achieve improvements to the building above and beyond the value of the simple repairs and engineers are advised to work with owners and users to achieve such outcomes.

4.4.3 Compliance

Major structural repair work will require a building consent in all cases. Designers should supply full documentation of the repair work on the same basis as new building work, to which should be added a detailed assessment of the whole building that establishes:

- › what damage the building has suffered
- › what implications the damage has for future performance
- › a summary (at least) of the total extent of repairs and retrofit required, specifically noting work that is not being undertaken if some elements have been deferred. If the work is being staged, note which areas of the building may be occupied and which must not at the various stages.

4.5 Building element repair

4.5.1 Foundations

Foundation repair of industrial building structures, where ground damage has occurred, will generally be confined to releveling or underpinning of existing shallow foundations. If floors are badly out of level, it may be possible to relevel them with injection grouting under the slab, or else they may have to be removed and re-laid. Options to mitigate future liquefaction hazard are limited in such cases, and in many instances repair will be on a comparable basis, or by treating concrete floor slabs as non-structural items where this is appropriate. Refer also to the tables within section 3.4 for factors to be considered in this assessment.

Construction of a compacted gravel base under a replacement floor slab could go some way in reducing vulnerability to damage in future earthquakes. Other methods that should provide improved performance in future earthquakes include compaction grouting or piling to underpin the walls or to support the floor.

4.5.2 Releveling

The need for releveling may be determined from the appropriate tables in section 3.4 of this document. The extent of releveling, if required, may be determined using the same criteria, but may also be further influenced by the practicality of actually performing the work.

Primary structure releveling, if required by the indicator criteria, should restore the primary structure as nearly as practicably possible to its original relative levels. That is, it should de-stress the building elements and connections to the greatest extent possible.

Slab on grade releveling may be required in order to meet the requirements of the indicator criteria of Table 3.2 and, if necessary, any HSE Act requirement, or any other building owner objective. This may include use of an overlay slab, noting that thickness of the overlay may cause issues (typically with edge frittering). This may be user-dependent from a serviceability perspective.

Releveling may be achieved by a variety of means, including mechanical jacking or grouting. However, industrial buildings will generally require lifting of the existing foundations (there are few structures where releveling the structure off the foundations is feasible) and geotechnical testing will usually be required to determine the ground conditions and appropriate releveling techniques. The extent of geotechnical investigations will vary from site to site and building to building, but should adequately identify the soils to below the depth of any underpinning and any significant variation across the site. If differential settlement has occurred it is recommended that testing is carried out adjacent to the unsettled section as well as the settled part to identify the possible causes of the settlement and the extent of underpinning that might be needed.

Where the subgrade is firm enough, lifting directly under the foundations may be possible. In many cases underpinning to a firm layer at depth with piles, compaction-grouting, or concrete may be needed. Where deeper underpinning is needed, the effect on future behaviour must be considered as the work needed to lift a settled area may stiffen the response such that a differential movement in the opposite direction could occur in a future earthquake. For many buildings, underpinning of one part of a building will force similar underpinning under the whole building. In general, underpinning must provide consistent stiffness capacity across the whole foundation in order to avoid future differential settlement.

4.5.3 Primary lateral load resisting systems

4.5.3.1 General

Depending on damage suffered, the repair of the primary lateral load resisting elements may adopt one of two general directions:

- › either a direct repair of the damage suffered in order to restore the integrity and capacity of the systems, or
- › provision of an alternative load path for the lateral load resistance, in which case repairs may be limited to work required to ensure gravity load resistance is maintained and the system is capable of withstanding the assessed displacements of the alternative lateral load resisting system, and that durability requirements are satisfied.

In practice, the determination of which approach to adopt requires consideration of a number of factors. The first of these is whether the primary system is compatible with the other elements of the structure. Where the primary system is too flexible, there may be compatibility issues with other elements of the structure that may be brittle and potentially require greater protection than can be reasonably provided by the primary system. Examples include end bay frames with brittle connections to panel elements or portal frames adjacent to end bay walls where a lack of roof bracing has resulted in damage to roofing and brittle cladding panels.

A second consideration is whether the primary mechanism is inherently brittle or incapable of resisting the effects of imposed ground deformations. An example of this is where brittle weld plate connections have been used to allow concrete wall panels to resist in-plane loads, on soft ground where localised displacement can overstress connections.

A third consideration is whether the damage can be readily repaired. In some cases, it may be more practical to simply provide an alternative load path, subject to consenting and/or exemption considerations.

In all cases, it is important to consider future resilience. Whether contemplating a direct repair or an alternative system, engineers are advised to consider whether more ductility or redundancy (as opposed to more strength) can be added to a system to deliver better performance in the future. In particular, the direct repair of brittle elements in kind should be avoided where possible. Noting that the extent of future movement could match the aggregate movement that has been experienced in the earthquakes to date, it is advised that sufficient ductility to accommodate future movements is incorporated into repaired or replacement systems, even if they are designed to the same lateral load level as the original structure.

4.5.3.2 Load demand

For buildings that are earthquake-prone, it is recommended that the building is improved to at least 34% NBS concurrent with the damage repair, rather than wait for earthquake-prone building policy to enforce strengthening at a later date.

A recommended additional design action on sites prone to liquefaction or differential settlement is to allow for future vertical displacement as a consequence of settlement. It is recommended that connections and bracing systems are design and detailed to accommodate loss of support from the greater of 6m, two full panel widths, or a single column. This is illustrated in Figure 4.1. Note that the lateral restraint of the system must be addressed in order to support the assumed deep beam behaviour. The connections must be detailed with due regard to the eccentricity of the connections and their stability in both compression and tension as well as in-plane actions.

The assessment of the foundation support provided by the adjacent wall panels should include consideration of stiffness of the underlying soils (crust).

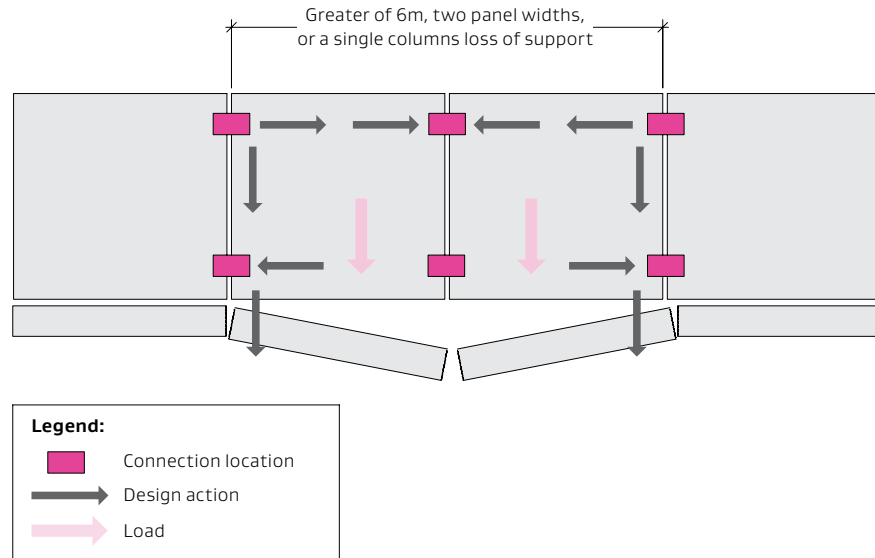
Figure 4.1: Derivation of load actions from loss of support

4.5.3.3 Moment resisting frames

The most common form of frame system in industrial buildings is the steel portal frame. In practice, these are highly flexible and have inherent ductility, even when lacking the degree of lateral bracing that might be expected to be present in order to meet current code requirements. These are unlikely to have direct damage, but their flexibility may have contributed to damage to other elements.

Similarly, timber frames are flexible and may have contributed to damage to secondary elements, but are rarely used with heavy cladding and so are unlikely to be of concern.

Full reinforced concrete moment frame systems are uncommon in industrial buildings although they may exist in older industrial facilities. Such frames are unlikely to be detailed with significant confinement and in many cases, may have plain round bar reinforcement with short and/or poorly located laps. These systems may be best dealt with by adding supplementary systems with compatible stiffness. New systems should be sized and detailed to maintain drifts within the indicator limits recommended in Table 3.4.

4.5.3.4 Braced frames

Some industrial buildings use braced frames in at least one direction. It is common for portal frames to use braced frames in the longitudinal (portal minor axis) direction particularly where lightweight cladding has been used over the full height or part of the height of the building.

In older braced frames, the bracing tends to be considerably lighter than would be required to meet current code, and generally has been detailed without consideration of the effects of inelastic deformation. These vulnerabilities may result in fractured braces, overstressed connections, or compatibility issues with cladding or other building elements.

In most cases where tension-only bracing is used, whether it is adequately sized or not, the bracing has been observed to have loosened. The bracing should generally be retightened in order to remove ‘slop’ from the system. Care should be taken in tightening bracing to ensure that the structure as a whole is not distorted, or that connections are not overstressed. This may require tightening from both ends of the braces, or even a sequence of partial tightening of all braces before final tightening, in order to control this. It is also important to first verify that there are no other factors contributing to the bracing having loosened that may require further evaluation of the system as a whole.

It is recommended that where tension-only bracing is being repaired, engineers follow the design and detailing provisions of the NZS 3404¹⁴. Assuming that the repairs are to meet the original capacity (or otherwise to any level less than 100% NBS), the braces and connections should be detailed for ductility, with notching to protect connections and other primary elements (especially those that carry gravity loads).

Proprietary connection systems should only be used where either the system is not subjected to inelastic actions or where the whole system or assembly (not just the individual components) has been tested and can be demonstrated to meet anticipated demand.

Proprietary bracing systems should only be used where they have been:

- a) tested to dynamic loading conditions and shown not to suffer brittle failure, and
- b) installed in accordance with the manufacturer’s instructions and will dependably remain in the installed state in service. That means that any locating or restraining nuts on rods must remain in the installed condition and not loosen.

It is the engineer’s responsibility to verify, on reasonable grounds, that any proprietary systems are capable of sustaining the imposed loads and displacements. Where bracing systems comprise both compression and tension bracing, consideration should be given to altered secondary structural behaviour that will follow the yield of the system (buckling of the compression brace).

4.5.3.5 Shear wall systems

Most industrial buildings that use tilt panels to provide seismic resistance have considerable redundancy in overall area of the panels and shear demand is low. The weakness of such systems is more likely to be in the connections used to transfer load from or to the panels.

Older tilt panel structures may have used bolted connections with shallow inserts. In such cases, the inserts are vulnerable to pull-out following cone failure. Anchors to the inserts may provide an element of security against complete failure but do not prevent the cone failure forming. A means of assessing this performance is available in NZS 3101¹⁵.

Many other industrial buildings use welded connections, with various forms of cast-in weld plates used in combination with site-welded plates. These details are also vulnerable due to their limited tolerance for movement and a number of other factors, eg brittle failure, corrosion impacts, insufficient capacity and the level of stress is indeterminate. In many cases, shrinkage, creep and thermal effects may have cracked these connections before the earthquakes. Depending on the method of the anchoring of the weld plates, these connections may continue to hold after the initial cone failure.

.....
14 NZS 3404:1997, Steel Structures Standard, Standards New Zealand.

15 NZS 3101:2006, Concrete Structures Standard, Standards New Zealand.

New connections will need to provide sufficient capacity to resist both the shear demand calculated from the seismic loading and the added demand that may result from future settlement.

4.5.4 Secondary elements

4.5.4.1 General

Secondary elements (ie those not part of the primary lateral load resisting system) may be considered in two ways:

- › elements that are part of the primary gravity system. These must be able to maintain their gravity load capacity (albeit under reduced actions according to AS/NZS 1170¹⁶) while undergoing the implied displacements (including settlement) from the lateral load resisting systems, or
- › other non-structural elements such as cladding. These must remain attached to the structure while subject to imposed seismic actions including both forces and displacements.

4.5.4.2 Slabs on grade (where not required to be part of the primary structure)

Where the ground floor slab is, or is able to be, separated from the primary structure (possibly by insertion of separate ground beams to act as lateral ties), it may be considered a secondary element, with no contribution to the structural performance. In this case, repair requirements will be determined by the usage of the building, potentially subject to health and safety requirements. This should be specifically discussed with the users in order to ascertain that the proposed repairs will be suitable.

Repair or replacement may be limited to areas where there are vertical dislocations in the slabs that may represent a tripping hazard. Care should be taken to avoid unnecessary damage to the damp proof membrane (DPM).

4.5.4.3 Wall panel repairs (secondary elements)

Repairs or replacement of wall panel elements may be required where panels have failed or been severely damaged. In general, repairs to panels may follow the approach described in section 4.3.

In cases where cold-drawn wire mesh has been used, the presence of a fully developed yield-line crack pattern may indicate complete or partial failure of the reinforcement. As these panels may need to resist a combination of both in-plane and out-of-plane loads, both need to be considered in assessing repair methods.

In-plane demand on panels is generally relatively low, with the most significant determining factor for panel reinforcement being out-of-plane actions arising either from erection loads or in-service design actions (wind or seismic). However, there may be a requirement to verify that instability (buckling) failure modes are prescribed in panels with high slenderness ratio (refer to NZS 3101 methodology).

.....
16 AS/NZS 1170.0, Structural Design Actions, Part 0, General Principles, Standards New Zealand.

Out-of-plane capacity may be achieved either by changing the load path (by adding structural steel or reinforced concrete transom or mullion elements), or by repair if the reinforcement is adequate. Previous guidance¹⁷ offered further advice on the assessment and repair of panels. This guidance is reproduced in full in Appendix C.

Where panels are suspended (such as spandrel elements), care must be taken to ensure that the connections are able to accommodate the possible increased design actions that may result from differential settlement, taking into account the potential focusing of settlement as noted in Figure 3.4(b). In such cases, further consideration should be given to whether the panel has a collector role, ie it carries tension/compression loads from roof bracing from one part of the building to another. A possible solution is to have all tension/compression loads carried at one level and to use face load restraint only in other connections as illustrated in Figure 4.2. This will allow the panel to articulate safely, provided that there is sufficient clearance for the possible panel rotation. Alternatively, consider replacement with lightweight deformable materials.

Figure 4.2: Possible panel restraint system for lintel elements

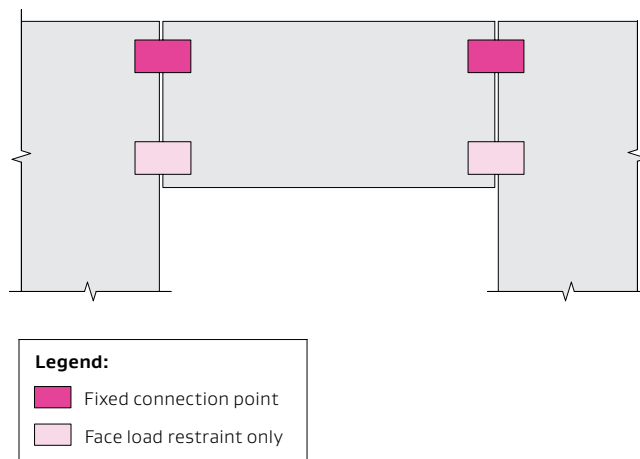

4.5.5 Repairing connections

Connections may be easily overlooked due to concerns over primary elements, but in many cases, the connections may be the major influencing factor on future performance.

4.5.5.1 Primary panel connections

As noted in section 3.3.4, precast panel connections may have 'locked-in' stresses as a result of building deformation, particularly in cases where there has been significant ground movement. This is particularly important in cases where the connections are considered to be brittle.

¹⁷ MBIE, Engineering Advisory Group. (2012). Draft Guidance on Detailed Engineering Evaluation of Earthquake Affected Non-residential Buildings in Canterbury, Part 3 Technical Guidance. Retrieved from www.sesoc.org.nz/images/DEE_Part%203_Technical_Guide_S8_R4.pdf

If the connections are considered to be potentially over-stressed, there are several actions that can be taken:

1. Easing. Connections may be progressively released and then re-fixed, having de-stressed the connection. For this method to be effective, it is important to consider the sequence of releasing and re-fixing carefully, in order to avoid transferring the overstressed condition to adjacent connections. This may need to be extended to adjacent panels also, if their movement could influence the panel under consideration.

All connections to a panel should be released before re-fixing the panel to avoid overstressing other connections to the panel or re-stressing connections that have already been eased. This will require consideration of temporary shoring or connections as panels are disconnected.

2. Add alternative connectors in the same general location. It may in many cases be more straightforward to put alternative connections in place in order to make potentially overstressed and/or damaged connections redundant. New connections should be designed to have inherent ductility. It may be acceptable to leave the existing damaged or brittle connections in place, provided that they do not adversely affect durability and that their eventual failure will not cause unnecessary damage.
3. In this case, the new connections should be designed to resist the entire demand, as the brittle connections may have to fail fully in order for the new connections to take up the load. The demand should be calculated to take account of Building Act requirements, including change of use and earthquake-prone buildings if applicable.
4. Provide alternative load paths. In some cases, the general connection configuration may be inappropriate to the performance of the panels. In such cases, it may be prudent to consider a change of structural configuration to either remove the affected panels from the primary load path, or to change the load path to the panel. An example of this may be to add a transom member to act as a collector element between portal frames, instead of relying on the panels and panel connections to perform this role.

In all cases, edge effects must be carefully considered in reviewing connections to thin panels. Caution should be exercised in fixing too near to an edge where (even if following manufacturers' recommended edge distance) fixings should be contained within panel trimmers, to avoid completely letting go in the event of failure. Shallow embedded post-fixed anchors should be avoided for the same reason. Epoxied anchors may be effective, but consideration of fire conditions is required.

4.5.5.2 Other connections

All other connections should be repaired in reflection of possible future demand. In general, the connection may have failed for one of two reasons – either it is undersized and therefore failed due to being over-stressed, or it has been subjected to excessive deformation due to the overall structural performance, which results in a compatibility-induced failure.

Each of these cases may demand a different approach, as follows:

Connection overstressed

If the building generally behaved adequately, the connection may be repaired in accordance with section 4.5.5, or increased in capacity to avoid future failure.

Note:

If it is elected to increase the connection capacity, downstream capacity should also be considered. That means that the remainder of the load path should be assessed for the increased loads that the new connection may transfer, to ensure that the increased capacity is able to be used.

If the building performed unexpectedly, leading to overstressing of the connection, the connection should be repaired and the building should be strengthened and/or have the load paths re-established in order to avoid future premature overstressing of the connection.

Excessive deformation leading to compatibility generated failure

In cases where there has been excessive deformation, it is important to determine whether this has been as a result of ground movement, or of unexpected building behaviour (including possible failure of other elements leading to alternative load paths developing).

In the case of excessive ground movement, unless the repairs include extensive foundation upgrading or ground improvement, future movement should be assumed to be at least as much again. In this case, the repair to the connections should allow for this movement without damage, and/or incorporate sufficient ductility to be able to maintain gravity capacity under reduced demand ($G + \psi_c Q$) while undergoing deformations.

If the building has performed unexpectedly, a decision is required as to whether to retrofit the building in order to either strengthen or change behaviour; or whether to accept the damage that has occurred and simply repair the building, ie restore it to its former capacity and accept the potential for future damage of the same order.

The decision making in this case must be by the owner/user, informed by engineering advice, provided that the minimum requirements of the Building Act are complied with.

Repair to connections should be considered in accordance with section 4.5.

Demand on new connections should be as derived from NZS 1170.5, section 8, with appropriate multipliers to achieve the required level of shaking resistance (%NBS). Note however, that in order to achieve compliance with section 17 of the Building Act, the relevant detailing and durability provisions of the Building Code should be met in full for the relevant design life. Subject to agreement with the owner and the BCA, it may be possible to use a reduced building life with respect to durability requirements, in order to more closely fit the remaining building life.

4.6 Common structural issues and options

A summary of common issues for the performance of industrial buildings is presented in Table 4.2 with recommendations on possible repair or retrofit solutions.

Table 4.2: Common problems and solutions for industrial buildings

Problem	Fix	Impact
Wall panels		
Brittle panel connections and/or cracked panels at the connection	a. Retrofit supplementary ductile connections. Epoxy cracks where weatherproofing compromised	Minimal, provided connections are accessible (usually the case)
Hard-drawn wire mesh reinforcing or inadequate reinforcing contents making panels prone to non-ductile face loading failure	a. Strengthen panels with externally applied fibre-reinforced polymer (FRP) sheets or strips	Expensive solution, but non-intrusive. Must be strong enough to remain elastic as FRP has minimal ductility.
	b. Introduce secondary steel or reinforced concrete members to reduce spans and strengthen panels	Possibly less expensive than FRP, but more intrusive, and may require supplementary foundations
	c. Replace affected panels	Expensive option in most cases, but may be practical where other changes are proposed
Panel span/thickness ratio too high, leading to panel buckling concerns (particularly in panels with minimal edge restraint)	a. Add intermediate steel or reinforced concrete elements to reduce spans and decrease span/thickness ratio	Very intrusive solution and new foundations may be required
	b. Replace affected panels	Expensive option in most cases, but may be practical where other changes are proposed
Roof level bracing		
Steel bracing inadequate	a. Retrofit new bracing or upgrade existing members and/or connections	Relatively simple fix, although may be extensive
Building separation		
Inadequate seismic separation	a. Increase width of seismic separation	Very extensive work will be required Likely to be very intrusive
	b. Tie adjacent structures together to prevent pounding	Requires common ownership or complex legal structures Structures must have compatible strength and stiffness and/or require strengthening to achieve this
	c. Specifically detailed connection designed to accommodate pounding	Requires consideration of likely pounding forces, resistance to them, and consequential damage

5. Rebuilds in liquefaction-prone areas

5.1 Introduction

The primary purpose of this section is to present an approach to the design and detailing of new industrial buildings that will enable sites in potentially liquefiable areas to be rebuilt on without incurring disproportionately high cost.

5.2 Regulatory requirements

Replacement (new) buildings must comply with the Building Act in full, but designers and owners should be aware that the means of complying may be broader than direct compliance with the Building Code in all respects. For example, the BCA may issue a waiver under section 67 of the Building Act to enable releveable structures to be used on potentially liquefiable sites, in preference to using deep piles to prevent differential movement.

5.2.1 Building Code requirements

Refer to section 2.1 for a more detailed description of the performance expectations for buildings under the New Zealand Building Code.

AS/NZS 1170 is referenced in Verification Method B1/VM1, which if followed, is treated as complying with Building Code clause B1. Buildings that are designed using AS/NZS 1170 (and to the provisions of the relevant material Standards) are required to satisfy the following primary design cases:

› **Ultimate Limit State (ULS)**

ULS is the state where design actions approach design capacity and reliable structural performance can no longer be predicted beyond this point. The low probability of rupture in the Building Code equates to ULS requirements. This level of seismic loading must not precipitate building collapse, including from the effects of liquefaction.

› **Serviceability Limit State (SLS)**

SLS is more problematic with the increased seismic hazard for Christchurch for liquefaction-prone sites, as liquefaction is predicted for many sites at the SLS level of shaking.

The serviceability limit state (SLS) presents the greatest challenge for sites with liquefaction potential. Sites which are expected to suffer some degree of liquefaction under the SLS shaking level need careful consideration in respect of the Building Code requirements. While measures such as intensive ground improvement or deep foundations may effectively mitigate against the effects of liquefaction (for the building, noting that surrounding services and infrastructure may be heavily damaged), they may be uneconomic in most cases. The high capital cost of such measures may significantly impact on the feasibility of the project. Under such circumstances, a different approach may be considered as noted below. However, a waiver may need to be issued by the BCA in order for the project to be consented.

Further guidance on recommended tolerable impacts during the SLS events is given in Appendix B.

5.3 Recommended approach

5.3.1 Site considerations

Given the highly variable nature of Christchurch soils, it is important to consider approaches on a site-by-site basis as opposed to broader application over a wide area such as a full subdivision. The size of the site is relevant, as edge effects must be considered if undertaking ground improvement or using a hard fill raft, which should extend beyond the outer walls of a building. Hence the ideal solution for a building located in the middle of a large site may not be applicable to a small narrow site (typical of many older industrial zones) where a building must extend right to the boundary.

Care should be taken in Flood Management Areas (FMAs) or otherwise flood-prone areas in how the ground floor level is to be built up. A significant surcharge that is restricted to the building plan area should be avoided, although if the entire site is built up, future performance may be acceptable. Alternatively the ground floor may be built up on polystyrene, to minimise differential settlement.

5.3.2 General design concepts

The site geotechnical conditions are the most significant consideration. For sites where the liquefaction potential is high, the need to accommodate or resist future movements will generally determine the foundation solution, according to the overall weight, type of construction and use of the building.

Ground improvement or deep piles are effective options to reduce the effects of liquefaction. These systems can reduce differential settlements to acceptable levels, but some ground movement and settlement must still be expected in the majority of cases. The ground may settle around a piled structure leaving a void below the floor and potentially breaking service connections. The cost implications of either may make future development uneconomic if the solution is required to extend over the full site including the ground floor slab (particularly in the case of piling). Moreover, ground improvement may only be applicable to a limited range of site and boundary conditions, particularly if site constraints require that the building plan footprint extend right to the site boundary. On a long narrow site where a raised building platform is planned, the edge effect must be considered.

Systems which rely on soil for lateral support should be avoided or used only with care. This includes cantilevering columns or other fixed base systems with post-hole footings or shallow foundations that may be vulnerable to differential settlement imposing excessive foundation rotations.

In cases where future ground performance is a determining factor in foundation design, it may be possible to separate the ground bearing floor slab (and foundation performance requirements) from the superstructure and foundations. This approach could be analogous to treating the ground bearing floor slab as a 'thick grey carpet', that is, the slab on grade may be simply replaced in the event of damaging displacements that are not within usable limits, without affecting the structure.

Using this approach, the primary structure should not be reliant on the floor slab. This means that the future performance of the primary structure may meet the Building Code requirements in full without regard to the slab on grade. However, the ground floor slab, failure of which may have no life safety impact, may be regarded as sacrificial or at least less critical. The ground floor may be constructed of reinforced concrete or potentially even asphaltic concrete if the intended use of the building permits it.

The superstructure should be kept as light as possible, with preference to using lightweight cladding systems where possible. Although the design of primary systems for limited or nominal ductility may be possible, higher levels of ductility should be added through the additional detailing provisions from the appropriate standards. This will reduce the risk of inappropriate structural behaviour following settlement, even when the settlement may not have been explicitly modelled.

5.3.3 Design decision consequences

It is important that designers communicate the consequences of design decisions clearly to owners and users.

Where the ground floor slab on grade has been separated as noted above, its failure (excessive deflection or excessive cracking) may have no immediate consequence, meeting the requirements of B1.3.4(a). As a readily repairable or replaceable element of the building, it may be considered that provided the building owners and/or users have been made aware of the frequency and potential severity of movement, they can make an informed decision as to whether they wish to accept the risk.

Future value of the building may be affected by this approach and this should also be discussed with owners. It is possible that if the slab is consented as a non-structural element in this way, it may be approved under a section 67 waiver, which may in turn require a note on the property file. This should be discoverable, if not published in a Land Information Memorandum (LIM). At the very least, it is expected the designers should note this approach carefully in a Design Features report, which would serve to alert future assessors and owners.

Risk transfer (insurance) may be possible, but consideration should be given to the cost and other impacts of this approach, noting that some businesses have been hampered by slow resolution and the impacts of working around areas requiring repair. A possible approach that may be discussed with brokers is to purchase insurance for the superstructure and its immediate foundation and leave the slab without cover (or under separate cover), as a means of obtaining cover at reasonable cost.

In any case, this approach should be clearly declared in all communication with owners, users and the Council (with respect to the Building Consent).

5.4 Demonstrating compliance

A key requirement for engineers in contemplating rebuilding work on liquefaction-prone ground is the means of demonstrating compliance.

5.4.1 Building Act

In accordance with the Building Act, all new building work must comply with the Building Code, to the extent required by the Building Act, whether or not a building consent is required. The inclusion of "to the extent required by this Act" within section 17 covers Building Act provisions such as the building consent authority being able to grant modifications and waivers to Building Code requirements (section 67).

5.4.2 Building Code

Section B1¹⁸ covers buildings, building elements and site work. Under B1, buildings, building elements, and site work must:

- › Clause B1.3.1 - have a low probability of rupturing, becoming unstable, losing equilibrium, or collapsing during construction or alteration and throughout their lives (generally referred to as the Ultimate Limit State (ULS)).
- › Clause B1.3.2 - have a low probability of causing loss of amenity through undue deformation, vibratory response, degradation, or other physical characteristics throughout their lives, or during construction or alteration when the building is in use (generally referred to as the Serviceability Limit State (SLS)).

In addition, Clause B1.3.4 states that due allowance shall be made (among others) for:

- › the consequences of failure
- › the intended use of the building.

5.4.3 Other considerations

While the following Canterbury Earthquakes Royal Commission recommendations have no binding legal status, they may influence the formulation of future Building Code requirements:

- › Recommendation 10 - where liquefaction or significant softening may occur at a site for the SLS earthquake, buildings should be founded on well-engineered deep piles or on shallow foundations after well-engineered ground improvement is carried out.
- › Recommendation 11 - conservative assumptions should be made for soil parameters when assessing settlements for the SLS.

Note:

The Canterbury Earthquakes Royal Commission was limited by its terms of reference to considering building failures within the CBD (and by inference to particular classified areas and occupancies).

.....
18 Building Regulations 1992, Schedule 1 (Building Code), clause B1.

5.4.4 Compliance

5.4.4.1 Documentation

As with any new building, the documentation prepared should be of sufficient quality and extent that the Building Consent Authority (BCA) is able to ascertain the likelihood of compliance with the Building Code, and ultimately that the building is able to be constructed. As a minimum, it is recommended that the following are provided:

- › full plans and specifications
- › a complete geotechnical report
 - addresses hazards specific to the site and that makes recommendations on appropriate foundation systems. It is further recommended that the geotechnical engineer to the project complete a review of the final documentation to verify that the foundation system is suitable for the site and proposed building. If necessary, the geotechnical report may need to be extended to suit alternative solutions
- › a full design features report
 - noting in particular any deviation from the Building Code Acceptable Solutions or Verification Methods, and any user-specific requirements that have been incorporated in the building
- › calculations.

In situations where, with regard to a particular aspect of building work, the design engineer requires that an application be made for a Building Code modification under section 67, then this application (and its approval) needs to be included with the Building Consent documentation.

5.4.4.2 Consenting

The consenting process will need to comply with the local BCA requirements. This may include the need for a pre-application meeting and independent peer review. The provision of Producer Statements for design and design review will be a matter for discussion with the BCA.

5.4.5 Foundations

On many sites where liquefaction has occurred, conventional shallow foundations are no longer appropriate to meet code criteria given the degree of liquefaction hazard. The issue is complicated by buildings extending to the property boundaries, the very large floor areas and, on many sites, the large depth of liquefiable soils. The reality is that it may no longer be economic to construct light commercial buildings that comply with the Building Code on some of these sites, unless the floor is separated from the structure and treated as a non-structural item.

Foundation options are described in the following topics.

5.4.5.1 Piling

Piling allows support to the building even when close to a boundary although piling equipment usually requires the piles to be offset inside the boundary wall. The resulting eccentricity may need moment resisting ground beams across the building which can then force the floor to be piled. There can be issues of pile integrity if a long pile length is required to penetrate to below liquefiable soils, both in terms of potential buckling and the degree of lateral deformation that the piles would be subjected to. The large floor areas for most light commercial buildings raise the question of what to do with these, as it is frequently uneconomic to pile the entire floor of large plan buildings, and floors in these situations may need to be treated as non-structural items.

5.4.5.2 Ground improvement

Methods range from surface treatments such as reinforced gravel raft to deep methods such as soil mixing and stone columns. One of the issues with ground improvement is that it is usually required to extend beyond the building footprint as there are issues in terms of the edge performance of any improved block of ground. Ground improvement is therefore problematic for sites where the structure is to be built to the boundary, and the lot size, economics and client expectation are such that bringing the walls in from the boundaries is impracticable. This could be overcome if adjoining sites are vacant and adjacent property owners co-operate and several properties are treated together. In some locations it is conceivable that a change of use may be necessary to allow for the greater expenditure of ground improvement or piling, and to allow space around the building.

As noted above, surcharging by building the soil up under the new floor slab may result in differential settlement in future events. This should only be done with specific geotechnical advice.

5.4.5.3 Lateral spread

Although lateral spread is not a significant problem for most industrial buildings in Christchurch there are some sites where it will need to be considered in the vicinity of existing or historic watercourses.

Piles are problematic in lateral spread areas as lateral ground movement can induce very large horizontal and eccentric vertical loads onto them, resulting in shear or bending failures. For smaller structures, incorporating a sliding head to the piles can allow relative movement of the pile and foundation (refer to section 15.2 of the MBIE Residential Guidance).

Raft foundations are likely to be a more practical option, but should be designed assuming ground extension under the raft will exert a tensile load across the raft that must be designed accordingly. However, neither of these solutions may be applicable to large buildings.

Ground improvement may be an appropriate treatment in these areas. Ground treatment decisions need to factor the cost against the potential benefits.

In cases where the site will allow it, it is best to locate new buildings as far as possible from the unsupported edge as this reduces the stretch across the building. However anywhere within a lateral spread zone, it is necessary to take lateral movement and stretch into account with a specific foundation design.

Away from lateral spread zones, ground over liquefied soils can still experience lateral movements and permanent lateral displacements in either compression or extension. Lateral movement should be considered in the design of new foundations. It is good practice to tie all foundations together to reduce the possibility of foundation displacement, ie separation. Historically, there have been prescriptive regulatory requirements for this but it is now contained implicitly within section 6 of AS/NZS 1170.0¹⁹. Tensile forces can be estimated by assuming ground movement under half the structure, and calculating frictional and earth pressure forces needed to generate sliding of the ground under the building foundations.

5.4.5.4 Raft foundations

Raft foundations may be a viable option on sites with limited liquefaction potential at an SLS level earthquake. Rafts can be effective in limiting differential settlement and internal deformation, but are still subject to global settlement and potential tilting. As well as simple reinforced concrete raft foundation, mitigation may be enhanced with a reinforced gravel raft, or ground treatment to a limited depth below the building. Edge effects may make these solutions difficult to apply on sites with buildings constructed to the boundary. One solution may be to cantilever the perimeter of the raft and supported walls to allow loss of ground support around the edge of the site.

5.4.5.5 Tie elements

Assuming that the ground floor slab is separated as proposed above, it is still recommended that tie elements are provided at frame lines to resist any lateral spread, whether resulting from ground movement or from building response. The design of the tie elements may be nominal, but it is recommended that each tie element is designed for the greater of:

- › actions derived from lateral analysis including the effects of differential settlement (and foundation separation), or
- › 15% of the factored vertical load on the foundation elements, or
- › a force equivalent to the capacity of 4-D20 reinforcing bars at frame lines.

Ties should be detailed to ensure that end anchorage and developed capacity at reinforcing laps are maintained, recognising that they may be subject to uplift or settlement actions. Liquefaction, if it occurs, should not affect independent tie members, which do not offer significant obstruction to the flow of ejecta.

5.4.6 Concrete floors

If the approach proposed above is followed, the slab on grade should be designed as a pavement following established techniques. Reinforced slabs with conventional joints may be used. Post-tensioned slabs on grade have been found to have performed well during the earthquakes and may offer increased protection against the effects of liquefaction and loss of support.

.....
19 AS/NZS 1170.0, Structural Design Actions, Part 0, General Principles, Standards New Zealand.

5.4.7 Primary structure

Thoughts on how resilience could be provided to the primary structure include the following:

- › providing regular foundation ties (as noted in section 5.4.5.5)
- › providing compression/tension members along the top of pre-cast panel walls to form an integrated deep beam (with the foundation beam) with the ability to span soft spots
- › designing connections to work with the compression/tension elements as described in Figure 4.1
- › discouraging cantilever panel type wall systems and encouraging frame action in industrial buildings in liquefaction-prone areas (avoid using soil for support).
- › providing roof bracing restraint of wall panels orientated in the same direction as the frames
- › designing penultimate end-bay portals (adjacent to stiff walls) for a displacements in accordance with Table C1 of AS/NZS 1170.0, ie ($\delta < \text{spacing}/400$).

5.4.8 Secondary structural elements

Secondary structural elements shall be designed to the relevant sections of the Building Code. Where elements could impact causing damage to other elements or connections, adequate clearance shall be added for the effects of differential settlement as well as direct seismic actions.

Appendix A: Building vulnerabilities

A.1 Key points

A.1.1 Structural assessment

Land damage has occurred and distortion of building superstructure has developed as a consequence. Structural assessment of superstructure is required to:

- › identify elements of structure that are vulnerable to failure now or in the future due to the damage
- › what damage those elements have sustained (if any) due to this distortion, ie critical superstructure damage
- › in terms of that future loading, identify:
 - whether the residual resistance of the element is sufficient to avoid future collapse in the normal course of events (excluding earthquake), eg normal gravity, wind and environmental loads (say 50 - 100 year return period)
 - what further distortion might occur in the building in a future moderate earthquake, ie approximating the SLS1 event
 - whether distortion associated with the above may lead to further damage and loss of structural function to an extent that it might become dangerous at that time.

A.1.2 Objective

The objective is to identify vulnerabilities that are typical for this type of building, and whose existence (or otherwise) should be checked out as part of the post-earthquake event inspection before occupancy (or access for 'make safe work'). This is particularly important in situations where:

- › land damage has occurred and the building has been distorted; and
- › these distortions have induced forces and/or displacements, in particular structural elements whose capacity to resist their normal design actions has been reduced as a consequence.

A.1.3 Liquefaction

In the case of land damage due to liquefaction, a separate evaluation of the superstructure is required for each of the following cases:

- › vertical settlement of land under SLS earthquake events, ie total and/or differential settlement
- › horizontal movement due to lateral spread and/or stretch under SLS and/or ULS conditions with the focus of this evaluation being on member connections within the superstructure
- › cantilever column rotation due to the effects of loss in ground support.

A.1.4 Connection details

Connection details exhibit different levels of robustness when subject to vertical and horizontal deformation, and load/deformation (or fragility) curves need to be developed for connections to cover each deformation case. If fragility relationships are to be developed, separate evaluations are to be undertaken.

A.1.5 Representative details

Some representative details for industrial buildings are included in the following topic.

A.2 Sample list of typical vulnerabilities for industrial buildings

A.2.1 Floor or ceiling joist/wall connection

Applies to	Floor joist seating in suspended floors
Susceptibility	Lateral stretch of ground - satisfactory, as suspended
Vertical settlement	Good (unless subject to settlement-induced tensions in floor)
Failure mode	Floor joists collapse downward due to loss of wall seating, putting occupants of space below at risk
Effects analysis	Potentially life critical to occupants of ground floor spaces

Figure A.1: Section through suspended floor/bearing wall connection in timber-framed construction

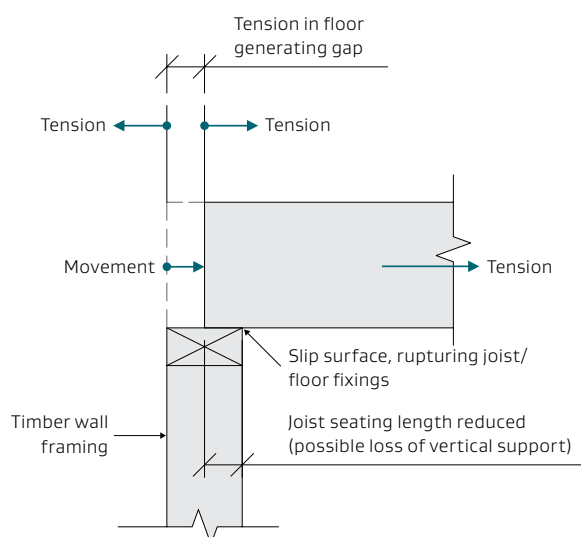

A.2.2 Floor joist/perimeter beam connection

Applies to	Floor joist seating on perimeter concrete foundation beam
Susceptibility	Lateral stretch of ground - poor
Vertical settlement	Good
Failure mode	Floor joists collapse downward due to loss of seating, leading to loss of support to loadbearing walls above etc
Effects analysis	Possibly life critical, but less so than the floor or ceiling joist/wall connection

Figure A.2: Section through foundation to floor connection in Type B construction

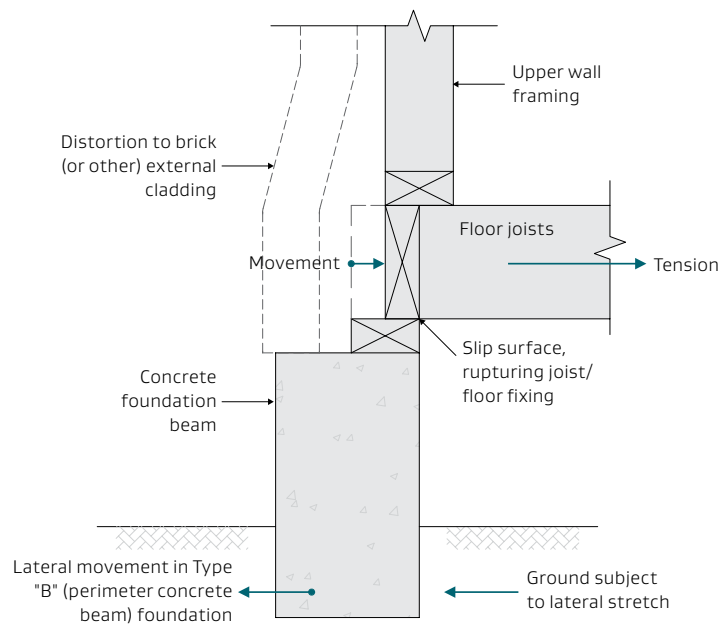

A.2.3 Precast floor (eg hollow core slab seating)

Applies to	Precast suspended floor supported on structural walls and/or beam system
Susceptibility	Lateral stretch of ground - good
Vertical settlement	Poor
Failure mode	Loss of slab seating and/or shear rupture, putting occupants of space below at risk
Effects analysis	Potentially life critical due to weighting of floor

Figure A.3: Section through shell/precast beam to hollow core floor connection in suspended floor system

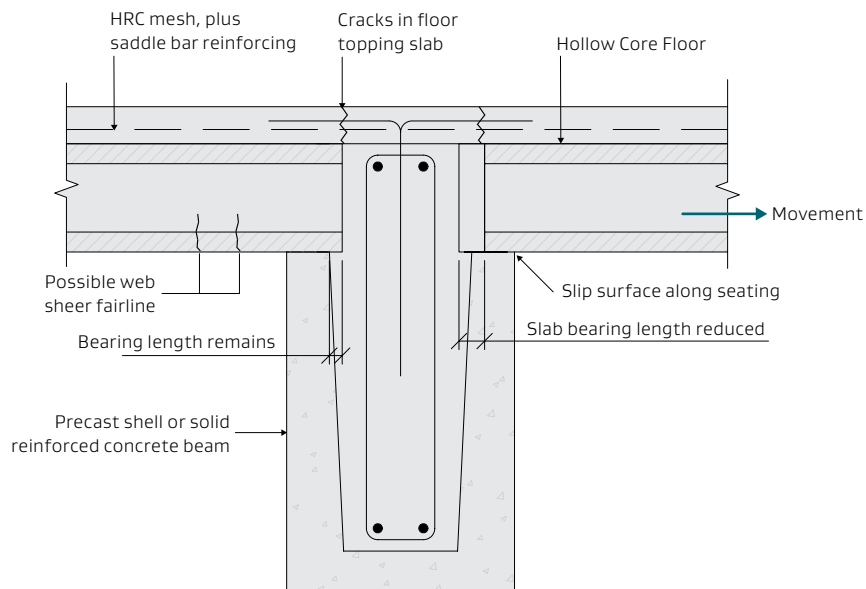

A.2.4 Precast wall panel 'pull in' by secondary roof steelwork

Applies to	Tilt up spanning wall panels cantilevered vertically from 'fixed base' and supporting roof purlins
Susceptibility	Vertical settlement and/or rotation of base foundation, leading to outward tilting of wall and 'pull in' tension in steelwork
Failure mode	Pull out of post drilled bolt fixings
Effects analysis	Reduction in gravity load carrying capability

Figure A.4: Section of precast panel wall and roof steelwork connection

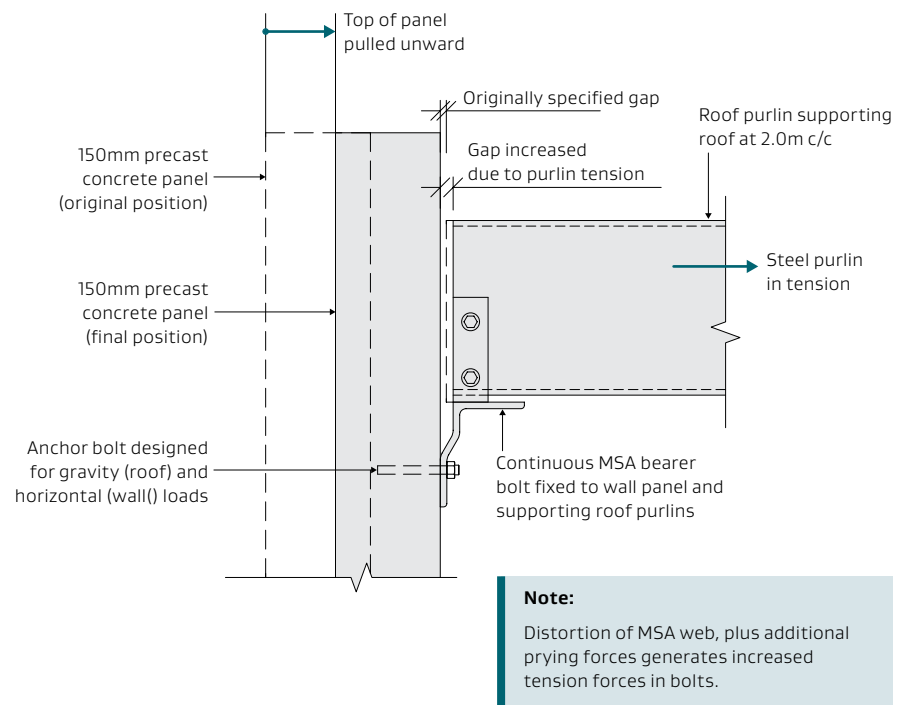

A.2.5 Steel weld plate connecting horizontally spanning wall panels to steel portal frame

Applies to	Horizontally spanning panels connected by weld plates to adjacent panels or to supporting portal frames
Susceptibility	Essentially rigid plate elements, often not designed for in-plane distortion or overload Tension forces arising from in-plane flexure, inclined strut action, or drying shrinkage
Failure mode	Bond/anchorage failure in concrete embedment Weld failure or rupture in connecting plate
Effects analysis	Horizontally spanning panel unable to resist face loading (refer NZS 1170.5 section 8/Parts)

Figure A.5: Steel weld plate to wall panel connection

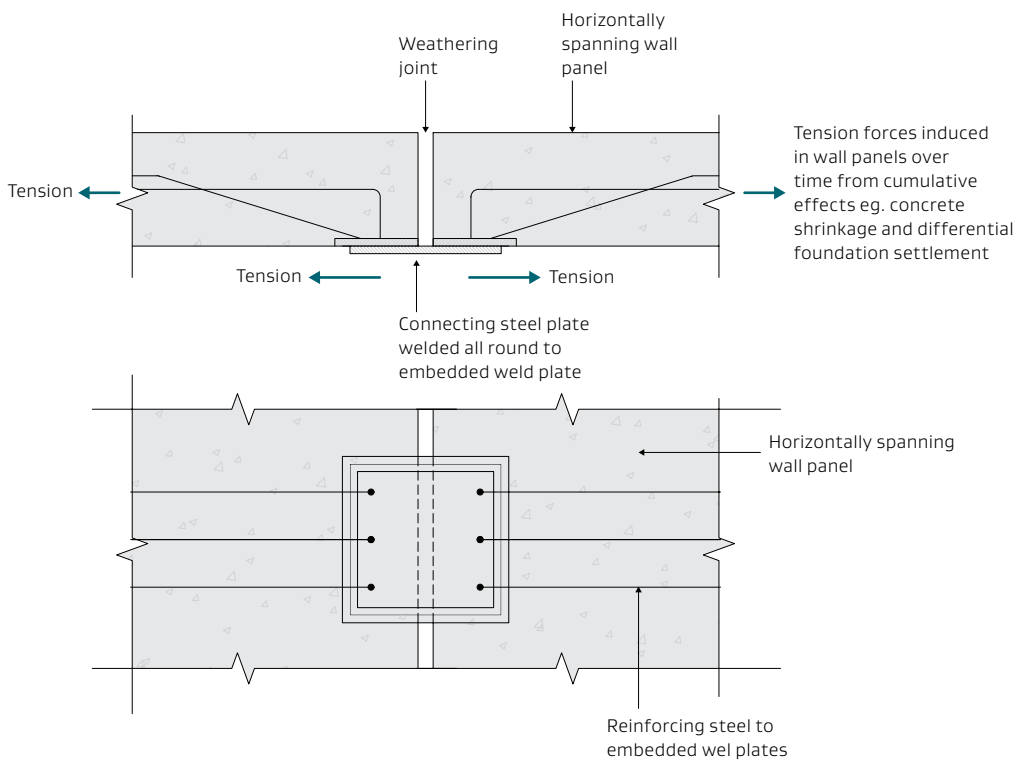

A.2.6 Precast lintel panel over doorway supported by weld plates and subject to differential settlement of supports

Applies to	Horizontally spanning panels connected by weld plates to adjacent panels or to supporting portal frames
Susceptibility	Tension/compression forces arising from in-plane flexure, inclined strut action, temperature or drying shrinkage effects.
Failure mode	Bond/anchorage failure in concrete embedment Weld failure or rupture in connecting plate
Effects analysis	Horizontally spanning panel unable to resist face loading (refer NZS 1170.5 section 8/Parts) Potential for panel collapse over egress way

Figure A.6: Wall elevation with lintel panels

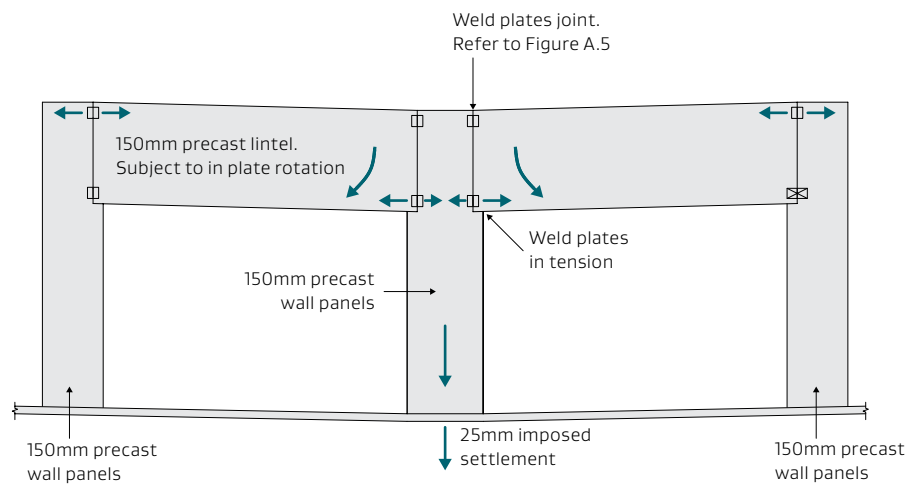

Appendix B: Tolerable impacts for reduced amenity

The amenity that an industrial building must continue to have after it has sustained damage in an SLS earthquake event can be summarised as:

- › the building remains accessible, functional and safe to occupy
- › the structure remains functional so that the building can continue to perform its intended purpose without excessive difficulty, cost, or loss of economy
- › there may have been some loss of amenity, eg gradients on floors, but the occupant is still able to function in terms of process or operations, eg materials handling
- › there is minor damage to the structure.

The scope of repair is set to return the amenity to at least the level that existed prior to the repair. The relationship of amenity to reuse is described in more detail in the 'Interpretation' column in Table B1 below.

Table B1: SLS performance expectations for industrial buildings

Key terms	Element	Interpretation	Comment
Performance attributes <ul style="list-style-type: none"> › Safety › Serviceability › Functionality › Other aspects, eg reparability, reinstatement 	Building	<p>Ability to be functional in terms of general commercial use. If design allows greater than normal deformation as being tolerable for a specified intended use, this information must be explicitly and prominently stated in consent documentation such that future purchasers can be informed.</p> <p>In particular cases, a Building Code modification, eg B1.3.2 may be required under section 67 of the Building Act.</p>	<p>Use may be function-driven and user-specified.</p> <p>Default Standards will apply, eg sanitation and fire egress, in the absence of an explicit statement on the consent documentation.</p>

Key terms	Element	Interpretation	Comment
Damage to structure (minor and repairable)	Foundation structure and integrated floor surfaces (structural)	<ul style="list-style-type: none"> › No rupture. › Defined thresholds in terms of gradient (L/240). Max absolute level differences (100mm). See explanatory note 1 below. › Adequate strength maintained in the interim. › Able to be relevelled simply to defined thresholds. 	<p>Applies to floors with structural (as opposed to non-structural) functions, eg props, ties and diaphragms. Some materials handling functions in industrial buildings will be more tolerant, eg normal pneumatic forklift operations.</p> <p>Structure gradient and level criteria will apply for specialist materials handling function, eg automated forklift access to pallet racking.</p> <p>Note: For specialist applications, eg automated forklifts servicing rack storage facilities, the gradient thresholds will need to be identified to ensure they match use.</p> <p>Applies to floors, where required, to maintain stability of superstructure. This may require the addition of tie beams to prevent spread of external column.</p>
	Non-structural floors on grade	Curvature and slope may exceed limits above, to degree that is acceptable for continued use.	<p>Applies to floors with non-structural functions, ie not required to maintain stability of superstructure.</p> <p>Where slab is required for the continued performance of the superstructure.</p>
	Walls - exterior	<p>Able to resist impact or distortion.</p> <p>Minor cracking to precast concrete panels at joints and in applied coatings.</p>	<p>Remains essentially watertight.</p> <p>Lateral structural integrity maintained.</p>
	Walls - interior	Minor cracking at lining joints.	Lateral structural integrity maintained.
	Non-integrated floor surfaces (non-structural)	<p>No rupture, but minor curvature acceptable.</p> <p>Readily repairable without compromising surrounding structure.</p>	<p>Applies to floors with non-structural functions, ie not required to maintain stability of superstructure.</p> <p>Ground supported and suitable for comparable repair, releveling, or resurfacing.</p> <p>Note: Gradient thresholds for different applications to be able to resist impact or distortion.</p>

Key terms	Element	Interpretation	Comment
Damage to building fabric and lining (minor)	Cladding external joinery	Some cracking to cladding panels due to in-plane distortion. Some cracking of linings above openings, eg doors, windows.	
	Roof	Roof claddings sound, intact and securely attached.	Capable of remaining weathertight. Capable of being re-established to maintain minimum falls.
Repairability	All elements	Repairable without relocation of personnel for more than six weeks or loss of function (25%) for more than three months.	Total cost of repairs is covered by normal insurance.
Building remains safe to occupy, accessible, and functional	Access doors (external)	Capable of daily operation and being secured (may need special maintenance, ie runner/catch adjustment, easing. Safe egress in emergency situation.	Requires ability to operate and maintain in this state for several months.
	Doors, windows	Minor jamming, ie may need to ease.	
Other aspects	Services	No significant damage to water, gas and electrical service connections that cannot be rectified by normal maintenance. Readily repairable damage to waste and storm water pipes.	Design of utility connectors to include provision for movement. Any loss of service will be due to malfunction of network utility system. Remedy will include use of temporary services, eg chemical toilets.
	Health and Safety	Owner needs to be able to demonstrate a healthy and safe environment for workers. Employee health and safety must not be compromised.	
	Damp-Proofing	Floor, cladding and fabric.	Requirement to prevent ground moisture from entering internal spaces.

Explanatory note for Table B1

- The 100mm limitation may be ignored in larger buildings where functionality is not compromised, provided that the gradient threshold set for amenity is not exceeded.

Appendix C: Low-rise panel structures

C.1 Acknowledgement

The content in this appendix is taken from the Draft Guidance on Detailed Engineering Evaluation of Earthquake Affected Non-residential Buildings in Canterbury, Part 3 Technical Guidance, Section 9 - Reinforced Concrete Wall Buildings, Appendix C - Commercial low-rise panel structures.¹

C.2 Introduction

A special form of concrete structural walls is precast panels, either connected to behave as composite wall sections, or as individual panels. Precast panels may be cast on-site or off-site according to the space available, the complexity of the panels, transportation considerations and contractor preference. Subject to the particular form of the structure, precast panels may behave in a similar fashion to in-situ concrete wall systems, provided that the connections are detailed accordingly. There are however specific detailing considerations that must be met in order to achieve this.

A specific form of precast panel structure that is included in this section is tilt panel structures, which generally (but not always) are attached to steel portal frames.

C.3 Seismic response characteristics and common deficiencies

C.3.1 Precast panel system behaviour

Precast panels may behave in similar fashion to in-situ concrete walls systems, provided that the detailing supports that. For further guidance on the requirements for composite action of precast elements, refer to NZS 3101² section 18. It is essential, as the first stage of any assessment of concrete panels being used as shear walls, that there is a determination made as to whether the panels are able to achieve composite action, and if not, what configuration of walls should be assumed for analysis.

The primary determining factor in assessing composite performance is connection detailing. The connections between panels must not be the limiting factor in assessing the strength of the system if full composite action is to be assumed.

¹ MBIE, Engineering Advisory Group. (2012). Draft Guidance on Detailed Engineering Evaluation of Earthquake Affected Non-residential Buildings in Canterbury, Part 3 Technical Guidance. Retrieved from www.sesoc.org.nz/images/DEE_Part%203_Technical_Guide_S8_R4.pdf

² NZS 3101:2006, Concrete Structures Standard, Standards New Zealand.

Issues to consider include:

- › base connections
- › vertical joints between panels
- › foundation compliance.

These are discussed in the following topics.

C.3.2 Base connections

Assuming a mechanical connection, it is noted that the maximum allowable ductility is $\mu=1.25$. Although it is possible that splices may be apparently staggered by using different lengths of ducting and splices, the necking effect created by confining a bar in a duct with high-strength grout will tend to cause all bars to yield at the same level. If present, this detail should be carefully inspected, noting that several instances of the failure of bars have been observed in such cases.

C.3.3 Vertical joints between panels

In cases where the joints run over the full thickness and height of the panels, with all of the horizontal steel lapping through the joint and the ends of the panels adequately roughened, it is probably reasonable to assume full composite behaviour. However, in many cases, the exterior of the panels have been precast with a rebated joint on the interior face of the panel, for architectural reasons. Refer to Figure C1: Vertical panel joints, for further graphical representation of these situations.

Case 1 is where the full section of the panel is jointed and full composite action is achieved.

Case 2 is a reduced section to provide a full precast surface face.

In Case 2, even if the effective steel area lapping through the joint is greater than or equal to the area of horizontal reinforcement required in the panel, there is still a need to consider the shear stress on the reduced section. If the degree of necking is too great, the shear stress may be too high, leading to separation of the panels at the joints.

If the area of steel is less than the area of horizontal steel required, full composite connection is not ensured, leading to separation of the panels as above. In such a case, the behaviour may be bounded by considering the wall as either a single composite unit, or as a series of vertical cantilevering elements.

In all cases, the horizontal steel should be capable of transferring the shear force as in shear friction across the joint.

C.3.4 Foundation compliance

Foundation compliance may be critical to the behaviour of the panels. The wall starters may have anchorages capable of developing the full tensile capacity of the bars, but this may be limited by the flexural or shear capacity of the foundation. Particularly when the panels are considered separately, this needs to be carefully considered, noting that it may be necessary to consider the panels and foundations as a series of free bodies with capacity limited by rocking. A diagrammatic example is given in Figure C2.

Note:

The capacity of the foundation may be a limiting factor, depending on whether the foundation has sufficient strength to develop the capacity of the vertical reinforcement in the wall panels or (more likely) the foundation capacity in shear or flexure will limit the overall system capacity.

Figure C1: Vertical panel joints

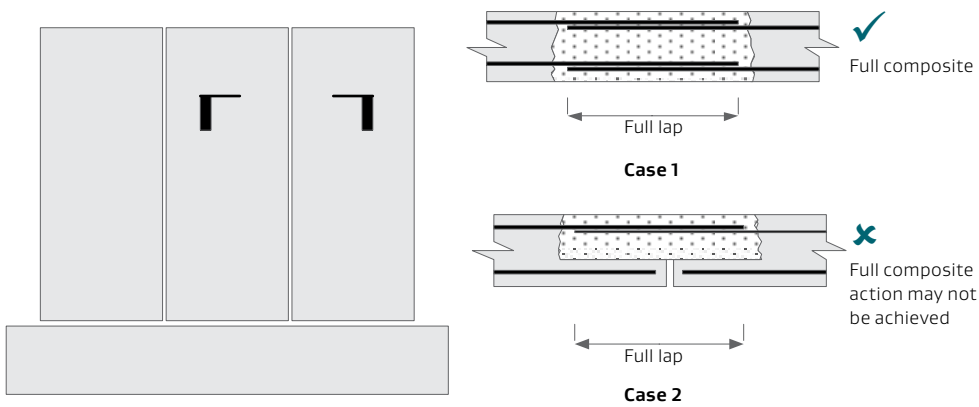
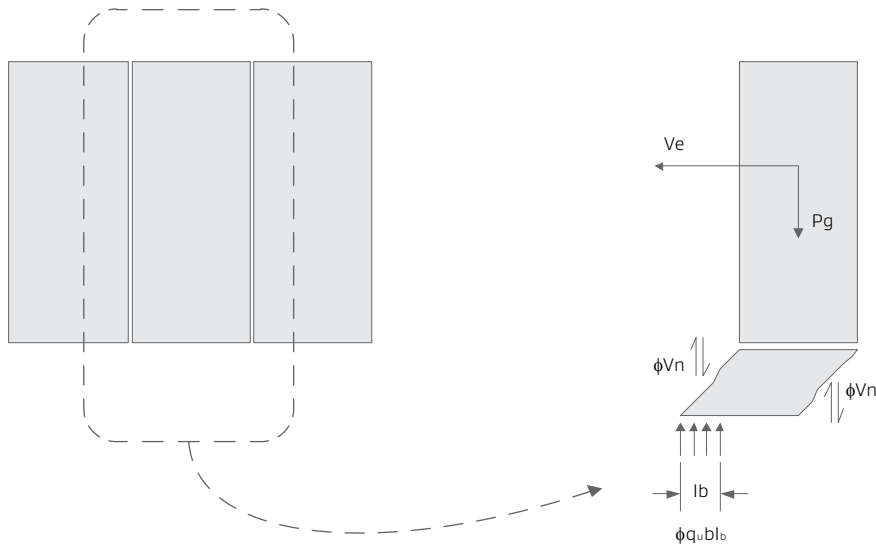

Figure C2: Free body analysis of panel behaviour



C.4 Single storey commercial applications

This section addresses commercial warehouses and factories where the panels are used as a combination of cladding and in-plane structural walls, often fabricated as tilt panels. Although these are a subset of precast panels, there are a number of unique behavioural characteristics of low-height panel structures.

In general, these are thin panels, designed for elastic or nominally ductile response. The behavioural characteristics of these panels are determined by a number of factors, detailed in following topics.

C.4.1 Reinforcement

Many earlier panels are reinforced with hard-drawn wire mesh. This steel is generally not capable of developing any significant strain beyond 'yield'. Furthermore, this reinforcement is often relatively light, reflecting the low demand at the time of design, which was often governed by lifting considerations for tilt panels. However, as the assessed demand under face loading may now be significantly greater than when the panel was designed, it is likely in many cases that the panels have inadequate reinforcement to resist even 33% of current code demand in order to satisfy earthquake-prone building criteria. In many cases, it is possible that the flexural capacity of the panel reinforcement may be less than the cracking moment of the panels.

C.4.2 Connections

Many early panel structures used weld plate connectors. These are often brittle, and have no allowance for shrinkage over the length of the structure. Where multi-bay structures contain panels over a significant length, it was common even prior to the earthquakes to see cracked connections at reasonably frequent intervals, as a result of shrinkage.

Consideration also needs to be given to the behaviour of panel connections in fire, according to factors such as the proximity to the boundary and the spread of fire requirements to adjacent structures.

C.4.3 Foundations

There are a variety of different foundation conditions for tilt panels. A common condition is to have the panels erected onto the portal foundation pads (with intermediate levelling pads if required), and to then cast the floor slab against the panels. Thickened foundations are often used to satisfy after-fire considerations.

C.4.4 Out-of-plane support

Many tilt panel structures have no additional support at the eaves junction of the panels, apart from connections at the edges of the panels at the portal knee. Therefore, the connection detail may determine the critical failure mechanism of the panel.

C.4.5 Stiffness compatibility

At the ends of portal frame structures, the last frame may be a braced frame, a full portal, or a series of panels. The stiffness of the end frame may have a significant impact on the behaviour of the last panel. If there is a significant stiffness differential between the end wall and the first portal, there will be warping actions on the panel as well as regular loading. This may also result in increased stresses on the connections.

C.5 Failure mode and repair assessment

Several common failure characteristics have been observed in tilt panel structures which require addressing.

C.5.1 In-plane and out-of-plane loading

C.5.1.1 Failure mode 1

Failure mode 1 is the full yield line development under face loading.

Note:

The yield line pattern will be dependent on the aspect ratio and support conditions of the panels.

Figure C3: Representative yield line pattern

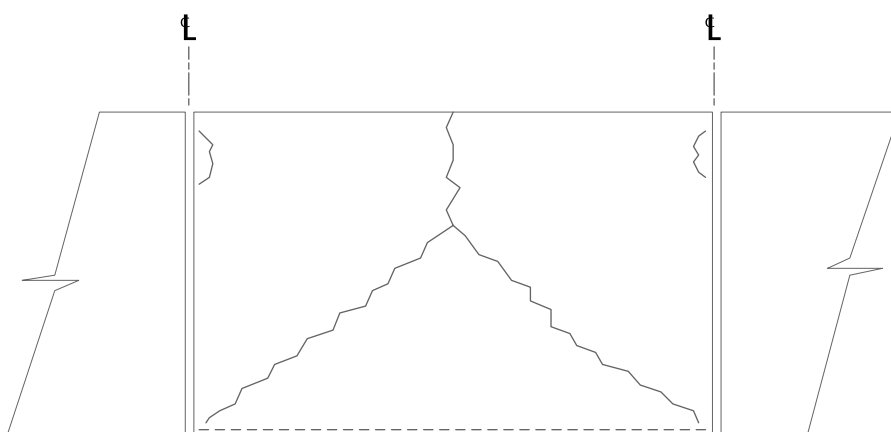

There are two possible variations to consider, according to the reinforcement in the panel.

Panel reinforced with mesh (excluding trimmers)

In this case, it is possible that the mesh may be fractured, or on the point of fracture. Non-destructive bar testing, as has been completed for many buildings in Christchurch, is ineffective, as cold-drawn mesh has no particular yield plateau, and hence no predictable point of failure. Therefore in such cases, an alternative load path is required for out-of-plane loading. This may require the addition of one or more horizontal or vertical support members, for example at eaves level and at mid-height (as shown in Figure C4). Care needs to be taken to ensure that fire requirements are satisfied.

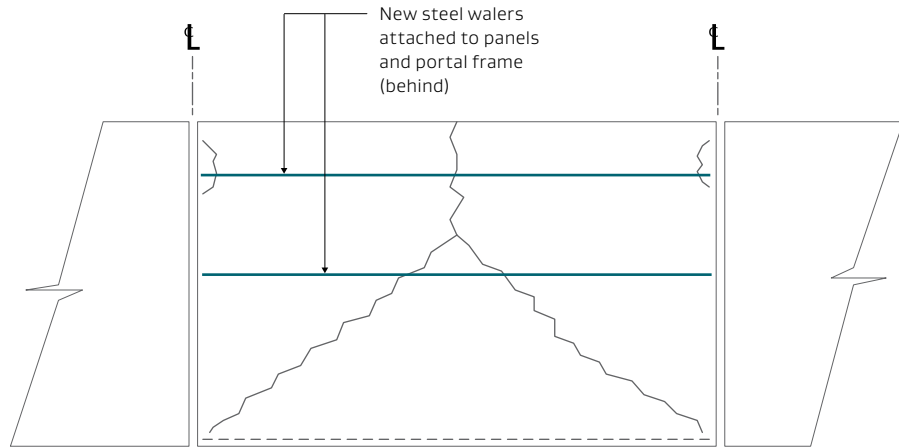
Figure C4: Possible arrangement of repair elements

The design of these elements must be in accordance with the Building Code. Connection of the panels to the new elements should reflect both the demand caused by the face loading and the required shear transfer to satisfy in-plane loading. This must also continue through to the consideration of the connection of the introduced elements back to the supporting members.

The repair to the panel itself is dependent on the in-plane loading demand and taking into account the connections of any introduced strengthening members, which may change the load path. Assuming that the panels are assessed for nominally ductile ($\mu=1.25$) loading, provided that the concrete strength is greater than or equal to the demand; that is:

$$\phi V_c \geq V_6,$$

(assuming $f'c = 25$ MPa, unless the original specification is available or testing is conducted to show otherwise).

Then the reinforcement is not required to resist seismic loading and the panel may be repaired for in-plane loading by epoxy injection and/or coating of the panel (in order to restore weatherproofing) if the cracks are not wide enough to epoxy.

If the concrete strength is less than the demand, then the capacity of the panels can be calculated as:

$$\%NBS = \frac{\phi V_c}{V_6}, \text{ excluding the reinforcement.}$$

If required, the panels may be replaced or strengthened. If the panel is not to be replaced, the panel may be repaired as above, using epoxy injection or coating.

Panel reinforced with conventional mild steel

If the panel is reinforced with conventional mild steel, the reinforcement should be able to continue to sustain the panel flexural and shear capacity, provided that the rotation is not excessive. Therefore the capacity of the panel can be calculated as normal, using conventional yield line theory, and compared to the demand, based on the support conditions and the required face loading according to NZS 1170.5, section 8.

The in-plane loading demand may be treated as above, but the mild steel reinforcement may be assumed to contribute fully to the capacity of the panel. Assuming that the panels are assessed for nominally ductile ($\mu=1.25$) loading, the capacity of the panels may be calculated as:

$$\%NBS = \frac{\phi(V_c + V_s)}{V_6} ,$$

As above, the panel may be repaired for in-plane loading by epoxy injection and/or coating of the panel (in order to restore weatherproofing).

The limiting capacity of the panels should be reported as the lesser of the in-plane or out-of-plane capacity.

C.5.1.2 Failure mode 2

Failure mode 2 is where there is only partial yield line development under face loading. This means less than 50% of the full panel yield line mechanism in evidence.

In this case, although it is possible that there is undetectable cracking, it is reasonable to assume that the reinforcement has not been subjected to excessive strain. The capacity of the panel in both in-plane and out-of-plane loading may be calculated conventionally, including the contribution of all reinforcement, whether it is mild steel or hard-drawn wire mesh.

C.5.1.3 Connection capacity

Demand on the connections for face loading may be calculated using the appropriate coefficient from the Parts and Connections section of NZS 1170.5. Assuming that the panels are simply supported at the base, the tributary area of panel contributing to the loading may be calculated as:

$$h_g = \frac{h_p^2}{2h_f} , \text{ where:}$$

h_p = the height of the panel

h_f = the height to the fixing (assumed to be at eaves level)

h_e = the effective height of the panel tributary to the fixing

Refer to Figure 5 below for graphic representation of the definitions above for a portal frame structure. In this case, the tributary weight of the panels on either side of the building, W_p , is:

$$W_p = \gamma_{conc} h_e s t, \text{ where:}$$

γ_{conc} = concrete density

s = portal frame spacing

t = panel thickness

and the connection design load, F_{ph} , is:

$$F_{ph} = C_p(T_p) C_{ph} R_p W_p, \text{ per equation 8.5(1) of NZS 1170.5}$$

Figure C5: Tributary area to connections

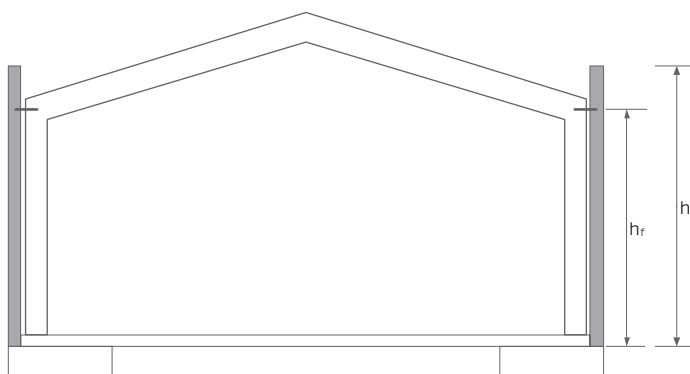

Note:

If new fixings are required, the connections must comply with the fire rating requirements of the Building Code, in full. Guidance is provided in clause 4.8 of NZS 3101:2006. Attention should be paid to the type of connection used as well as to the required design loads, noting that adhesive anchors should only be used if they have achieved the appropriate fire resistance ratings through test.

C.6 Reporting results

The results of the evaluation should be reported according to Part 2 of the DDE Guidelines.³ The capacity of the panels is the lesser of the %NBS scores calculated for the in-plane or out-of-plane loading.

³ MBIE Engineering Advisory Group. (2012). Draft Guidance on Detailed Engineering Evaluation of Earthquake Affected Non-residential Buildings in Canterbury, Part 2 Evaluation Procedure. Retrieved from <http://sesoc.org.nz/images/Detailed-Engineering-Evaluation-Procedure.pdf>

Appendix D: Definitions

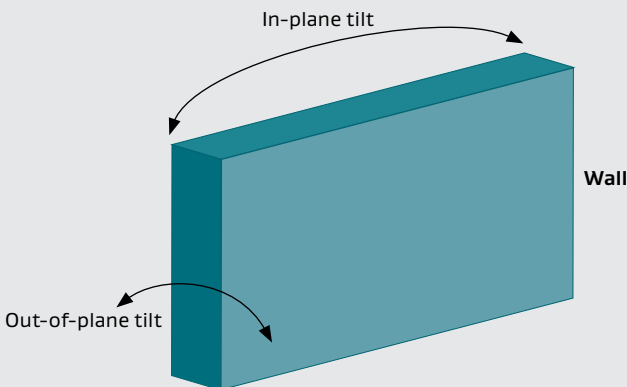
Term/Acronym	Definition
Building	This refers to the building as a whole, incorporating buildings having multiple titles rather than a standalone, single-titled commercial building.
CGD	Canterbury Geotechnical Database
Damage threshold	The point at which a building's characteristics no longer meet expected performance.
DEE	The detailed engineering evaluation documents providing the process and procedures to be used by engineers in medium-term evaluation of building damage.
Differential settlement	Varying foundation settlement along or across a building as referenced to surface subject to planar tilt.
FFL	Finished floor levels
FMA	Flood management areas, as defined by the Christchurch City Council District Plan.
Foundation piles	Piles at sub-floor level generally terminating at a pile cap on grade.
Foundation strip footing	Load bearing foundation beams at ground surface not relying on floor slabs for load distribution.
Geotechnical Professional	CPEng geotechnical engineer with suitable relevant training and experience in industrial foundations and liquefaction assessment.
In-plane/out-of-plane tilt	<p>These terms are used to express movement of a concrete (or other) wall panel.</p>  <p>The diagram shows a 3D perspective of a rectangular wall. Two curved arrows illustrate different types of tilt: one arrow along the top surface of the wall is labeled 'In-plane tilt', and another arrow pointing away from the front face of the wall is labeled 'Out-of-plane tilt'. The word 'Wall' is written to the right of the object.</p>
MBIE Residential Guidance	Ministry of Business, Innovation and Employment. (2012). Repairing and rebuilding houses affected by the Canterbury earthquakes. Available at www.dbh.govt.nz/guidance-on-repairs-after-earthquake

Term/Acronym	Definition
Net structural benefit test	A process of performance evaluation whereby the benefits of the new works proposed to be undertaken within parts of a building are compared to the detrimental effects of those works to the building as a whole.
Non-uniform settlement of a portion of the building	This term is used to describe the displacement of part of a structure where there is a step change in floor level with comparatively level floors in each part.
Partial rebuild	When a portion of a building's foundations (consisting of 100% of one or more units along the building) requires replacement and a portion of the building will remain in place.
Planar tilt	A gradual or cumulative settlement of a building resulting in the whole building tilting uniformly.
Rupture	A structural failure or significant building distress.
Site performed poorly (from section 14.2.1 of the MBIE Residential Guidance)	A site is considered to have performed poorly if: <ul style="list-style-type: none"> › there were large amounts of liquefaction ejecta during the earthquake events › there was extensive ground cracking of the site › there are large ground undulations as a result of the earthquake events › the building has settled relative to the surrounding land.
Unit	A single industrial occupancy within a larger building complex.
URM	Unreinforced concrete block or brick masonry wall.

GUIDANCE

BUILD IT RIGHT | The groundwork
CANTERBURY for good decisions.



**MINISTRY OF BUSINESS,
INNOVATION & EMPLOYMENT**
HĪKINA WHAKATUTUKI