

## Compliance Document for New Zealand Building Code Clause B1 Structure

Prepared by the Department of Building and Housing

This Compliance Document is prepared by the Department of Building and Housing. The Department of Building and Housing is a Government Department established under the State Sector Act 1988.

Enquiries about the content of this document should be directed to:



**Department of  
Building and Housing**  
*Te Tari Kaupapa Whare*

Department of Building and Housing  
PO Box 10-729, Wellington.  
Telephone 0800 242 243  
Fax 04 494 0290  
Email: [info@dbh.govt.nz](mailto:info@dbh.govt.nz)

**Compliance Documents are available from [www.dbh.govt.nz](http://www.dbh.govt.nz)**

### New Zealand Government

© Department of Building and Housing 2010

This Compliance Document is protected by Crown copyright, unless indicated otherwise. The Department of Building and Housing administers the copyright in this document. You may use and reproduce this document for your personal use or for the purposes of your business provided you reproduce the document accurately and not in an inappropriate or misleading context. You may not distribute this document to others or reproduce it for sale or profit.

The Department of Building and Housing owns or has licences to use all images and trademarks in this document. You must not use or reproduce images and trademarks featured in this document for any purpose (except as part of an accurate reproduction of this document) unless you first obtain the written permission of the Department of Building and Housing.

## Status of Compliance Documents

Compliance Documents are prepared by the Department of Building and Housing in accordance with section 22 of the Building Act 2004. A Compliance Document is for use in establishing compliance with the New Zealand Building Code.

A person who complies with a Compliance Document will be treated as having complied with the provisions of the Building Code to which the Compliance Document relates. However, a Compliance Document is only one method of complying with the Building Code. There may be alternative ways to comply.

Users should make themselves familiar with the preface to the New Zealand Building Code Handbook, which describes the status of Compliance Documents and explains alternative methods of achieving compliance.

Defined words (italicised in the text) and classified uses are explained in Clauses A1 and A2 of the Building Code and in the Definitions at the start of this Compliance Document.

<b>B1: Document History</b>			
	<b>Date</b>	<b>Alterations</b>	
First published	July 1992		
Amendment 1	September 1993	p. ix–xii, References p. 1, 1.3, 1.4.1–1.4.3, 2.1, 2.2, 3.1–3.3, 4.1, 5.1 p. 2, 6.1, 6.2, 8.1, 9.1 p. 4, 11.1, 12.1 p. 5, 1.2, 2.1, 2.2, 3.1, 3.2, 4.1, 4.2, 6.1, 6.2, 7.1	p. 9, 1.0.1, 1.0.5 b) c) p. 10, 2.3.5 p. 13, Figure 4 p. 14, 2.3.6 p. 16, 2.3.8, 2.3.9 p. 34, Table 1 p. 47, 1.0.1 pp. 49-54, Index
Amendment 2	19 August 1994	pp. i and ii, Document History pp. vii and viii, Contents pp. x and xi, References p. xiv, Definitions p. 1, 1.4.2, 5.1 p. 2, 6.1 p. 5, 1.3, 3.1, 4.1 p. 6, 7.1 p. 10, 2.3.5 p. 12, Figure 3 p. 13, Figure 4 p. 14, 2.3.6, 2.3.7 p. 15, Tables 4 and 5	p.16, 2.4.1 p. 21, Figure 2 p. 22, Figure 3 p. 32, 2.2.4 p. 33, 1.0.2 p. 34, 3.2.1, Table 1 p. 35, 4.1, 4.1.2, 4.1.3, 4.2.1, 4.2.2, 4.3, 4.3.1, 5.0.1, Table 2 p. 36, 6.1.2, 7.1, 7.1.1 p. 37, 7.3.4 pp. 49, 50, 51, 54, Index
Reprinted incorporating Amendments 1 and 2	October 1994		
Amendment 3	1 December 1995	p. ii, Document History p. ix, References p. 1, 3.1	p. 5, 6.2 p. 50, Index
Reprinted incorporating Amendments 1, 2 and 3	July 1996		
Amendment 4	1 December 2000	p. ii, Document History pp. vii and viii, Contents pp. ix – xii, Revised References pp. xiii and xiv, Definitions	pp. 1–4A, Revised B1/VM1 pp. 5 and 6, Revised B1/AS1 pp. 33–63, Revised B1/VM4 p. 65, Revised B1/AS4 pp. 67–72, Revised Index

<b>B1: Document History (continued)</b>			
Erratum	9 February 2001	p. 46, 4.3.2 a) i)	
Amendment 5 incorporating Erratum	1 July 2001	p. 2, Document Status p. 3, Document History p. 7, References	p. 41, 1.7.2 Comment p. 49, 2.2.4 p. 48, 1.9.1 b) i)
Amendment 6	1 March 2005	p. 11, References	
Amendment 7	1 April 2007	pp. 11–12, 14, References pp. 15–16, Definitions	p. 18, 6.1
Amendment 8	Published 1 June 2008 Effective 1 December 2008	p. 2, Document Status p. 3, Document History p. 9, Contents pp. 11–14, References pp. 15–16, Definitions	pp. 17–22B, B1/VM1 p. 51, B1/VM4 1.0.5, 2.0.1 p. 56, B1/VM4 Figure 2 p. 70, B1/VM4 B1.0.2 pp. 83–84, 86 Index
Amendment 9	Published 30 June 2010 Effective 30 September 2010	pp. 2–3, Document History, Status, pp. 11–14, References p. 20, B1/VM1 2.2.13 p. 21, B1/VM1 3.0, 5.1 pp. 22–22B, B1/VM1 11.0 pp. 23–24, B1/AS1 6.0, 6.1, 6.2, 6.3, 6.4, 7.1, 7.2, 7.3, 7.4	p. 27, B1/AS2 1.0.5 p. 44, B1/AS3 1.7.9 p. 47, B1/AS3 1.8.5, 1.8.6 p. 49, B1/AS3 2.1.1, 2.2.4 p. 63, B1/VM4 4.3.2 p. 67, B1/VM4 5.3.1
Reprinted incorporating Amendments 4–9	30 September 2010		
Erratum 1	30 September 2010	p. 21, B1/VM1 3.1	
<b>Note:</b> Page numbers relate to the document at the time of Amendment and may not match page numbers in current document.			

## Document Status

The most recent version of this document, as detailed in the Document History, is approved by the Chief Executive of the Department of Building and Housing. It is effective from 30 September 2010 and supersedes all previous versions of this document.

People using this Compliance Document should check for amendments on a regular basis. The Department of Building and Housing may amend any part of any Compliance Document at any time. Up-to-date versions of Compliance Documents are available from [www.dbh.govt.nz](http://www.dbh.govt.nz)



## New Zealand Building Code Clause B1 Structure

This Clause is extracted from the New Zealand Building Code contained in the First Schedule of the Building Regulations 1992.

16	<i>Building Regulations 1992</i>	1992/150
FIRST SCHEDULE— <i>continued</i>		
<b>Clause B1—STRUCTURE</b>		
<b>Provisions</b>	<b>Limits on application</b>	
<b>OBJECTIVE</b>		
<b>B1.1</b> The objective of this provision is to:		
<ul style="list-style-type: none"> <li>(a) Safeguard people from injury caused by structural failure,</li> <li>(b) Safeguard people from loss of <i>amenity</i> caused by structural behaviour, and</li> <li>(c) Protect <i>other property</i> from physical damage caused by structural failure.</li> </ul>		
<b>FUNCTIONAL REQUIREMENT</b>		
<b>B1.2</b> <i>Buildings, building elements and sitework</i> shall withstand the combination of loads that they are likely to experience during <i>construction or alteration</i> and throughout their lives.		
<b>PERFORMANCE</b>		
<b>B1.3.1</b> <i>Buildings, building elements and sitework</i> shall have a low probability of rupturing, becoming unstable, losing equilibrium, or collapsing during <i>construction or alteration</i> and throughout their lives.		
<b>B1.3.2</b> <i>Buildings, building elements and sitework</i> shall have a low probability of causing loss of <i>amenity</i> through undue deformation, vibratory response, degradation, or other physical characteristics throughout their lives, or during <i>construction or alteration</i> when the <i>building</i> is in use.		
<b>B1.3.3</b> Account shall be taken of all physical conditions likely to affect the stability of <i>buildings, building elements and sitework</i> , including:		
<ul style="list-style-type: none"> <li>(a) Self-weight,</li> <li>(b) Imposed gravity loads arising from use,</li> <li>(c) Temperature,</li> </ul>		

FIRST SCHEDULE—*continued*

Provisions	Limits on application
<ul style="list-style-type: none"> <li>(d) Earth pressure,</li> <li>(e) Water and other liquids,</li> <li>(f) Earthquake,</li> <li>(g) Snow,</li> <li>(h) Wind,</li> <li>(i) <i>Fire</i>,</li> <li>(j) Impact,</li> <li>(k) Explosion,</li> <li>(l) Reversing or fluctuating effects,</li> <li>(m) Differential movement,</li> <li>(n) Vegetation,</li> <li>(o) Adverse effects due to insufficient separation from other <i>buildings</i>,</li> <li>(p) Influence of equipment, services, non-structural elements and contents,</li> <li>(q) Time dependent effects including creep and shrinkage, and</li> <li>(r) Removal of support.</li> </ul> <p><b>B1.3.4</b> Due allowance shall be made for:</p> <ul style="list-style-type: none"> <li>(a) The consequences of failure,</li> <li>(b) The intended use of the <i>building</i>,</li> <li>(c) Effects of uncertainties resulting from <i>construction</i> activities, or the sequence in which <i>construction</i> activities occur,</li> <li>(d) Variation in the properties of materials and the characteristics of the site, and</li> <li>(e) Accuracy limitations inherent in the methods used to predict the stability of <i>buildings</i>.</li> </ul> <p><b>B1.3.5</b> The demolition of <i>buildings</i> shall be carried out in a way that avoids the likelihood of premature collapse.</p> <p><b>B1.3.6</b> <i>Sitework</i>, where necessary, shall be carried out to:</p>	

18

*Building Regulations 1992*

1992/150

FIRST SCHEDULE—*continued*

Provisions	Limits on application
<p>(a) Provide stability for <i>construction</i> on the site, and</p> <p>(b) Avoid the likelihood of damage to <i>other property</i>.</p> <p><b>B1.3.7</b> Any <i>sitework</i> and associated supports shall take account of the effects of:</p> <p>(a) Changes in ground water level,</p> <p>(b) Water, weather and vegetation, and</p> <p>(c) Ground loss and slumping.</p>	





# Contents

	Page		
<b>References</b>	<b>11</b>	<b>Acceptable Solution B1/AS1</b>	<b>23</b>
<b>Definitions</b>	<b>15</b>	(Revised by Amendment 4)	
<b>Verification Method B1/VM1</b>	<b>17</b>	<b>General</b>	<b>23</b>
<b>General</b>	<b>17</b>	<b>1.0 Explanatory Note</b>	<b>23</b>
<b>1.0 General</b>	<b>17</b>	<b>2.0 Masonry</b>	<b>23</b>
		2.1 NZS 4229	23
<b>2.0 Structural Design Actions Standards</b>	<b>17</b>	<b>3.0 Timber</b>	<b>23</b>
		3.1 NZS 3604	23
<b>3.0 Concrete</b>	<b>21</b>	<b>4.0 Earth Buildings</b>	<b>23</b>
3.1 NZS 3101: Part 1	21	4.1 NZS 4299	23
<b>4.0 Concrete Masonry</b>	<b>21</b>	<b>5.0 Stucco</b>	<b>23</b>
4.1 NZS 4230	21	5.1 NZS 4251	23
<b>5.0 Steel</b>	<b>21</b>	<b>6.0 Drains</b>	<b>23</b>
5.1 NZS 3404: Part 1	21	6.1 NZS 4452	23
5.2 AS/NZS 4600	21	6.2 NZS 7643	23
<b>6.0 Timber</b>	<b>22</b>	<b>7.0 Glazing</b>	<b>24</b>
6.1 NZS 3603	22	7.1 NZS 4223	24
<b>7.0 Aluminium</b>	<b>22</b>	<b>8.0 Small Chimneys</b>	<b>24</b>
7.1 AS/NZS 1664.1	22	<b>9.0 Timber Barriers</b>	<b>24</b>
		<b>Verification Method B1/VM2</b>	<b>25</b>
<b>8.0 Earth Buildings</b>	<b>22</b>	<b>Timber Barriers</b>	
8.1 NZS 4297	22	<b>Acceptable Solution B1/AS2</b>	<b>27</b>
<b>9.0 Foundations</b>	<b>22</b>	<b>Timber Barriers</b>	
<b>10.0 Siteworks</b>	<b>22</b>	<b>1.0 Scope</b>	<b>27</b>
10.1 NZS 4431	22	<b>2.0 Construction</b>	<b>27</b>
<b>11.0 Drains</b>	<b>22</b>	2.1 General	27
11.1 NZS/AS 3725	22	2.2 Top rails	27
<b>12.0 Windows</b>	<b>22B</b>	2.3 Balusters	27
12.1 NZS 4211	22B	2.4 Bottom rails	33
		2.5 Palings	33
		2.6 Timber moisture content	33
		2.7 Alternative details	34
		<b>Verification Method B1/VM3</b>	<b>35</b>
		<b>Small Chimneys</b>	
		<b>Acceptable Solution B1/AS3</b>	<b>37</b>
		<b>Small Chimneys</b>	
		<b>Scope</b>	<b>37</b>

Amend 3  
Dec 1995

Amend 4  
Dec 2000

Amend 2  
Aug 1994

Amend 8  
Dec 2008

Amend 4  
Dec 2000

<b>1.0 Chimney Construction</b>	<b>37</b>	<b>5.0 Pile Types</b>	<b>66</b>
1.1 General	37	5.1 Concrete piles	66
1.2 Chimney wall thickness	37	5.2 Steel piles	67
1.3 Foundations	37	5.3 Timber piles	67
1.4 Hearths	41	<b>Appendix A (Informative)</b>	<b>69</b>
1.5 Chimney breasts	41	<b>A1.0 Site Investigations</b>	<b>69</b>
1.6 Reinforcing	41	<b>Appendix B (Informative)</b>	<b>70</b>
1.7 Chimney restraint	41	<b>B1.0 Serviceability Limit State Deformations (Settlement)</b>	<b>70</b>
1.8 Materials and construction	47	<b>Appendix C (Informative)</b>	<b>71</b>
1.9 Systems to resist horizontal earthquake loadings	47	<b>C1.0 Description of Wall, Limit States and Soil Properties</b>	<b>71</b>
<b>2.0 Solid Fuel Burning Domestic Appliances</b>	<b>49</b>	<b>C2.0 Earth Pressure Coefficients</b>	<b>72</b>
2.1 Chimneys	49	<b>C3.0 Load Factors and Strength Reduction Factors</b>	<b>72</b>
2.2 Hearth slab	49	<b>C4.0 Notation</b>	<b>72</b>
<b>Verification Method B1/VM4 Foundations</b>	<b>51</b>	<b>C5.0 Loadings</b>	<b>73</b>
<b>1.0 Scope and limitations</b>	<b>51</b>	<b>C6.0 Surcharge Pressures at Toe</b>	<b>75</b>
<b>2.0 General</b>	<b>51</b>	<b>C7.0 First Ultimate Limit State (short term static foundation bearing failure)</b>	<b>76</b>
<b>3.0 Shallow Foundations</b>	<b>52</b>	<b>C8.0 Second Ultimate Limit State (short term static foundation sliding failure)</b>	<b>77</b>
3.1 General provisions	52	<b>C9.0 Third Ultimate Limit State (short term foundation bearing failure under EQ)</b>	<b>77</b>
3.2 Ultimate and design bearing strength and design bearing pressure	52	<b>C10.0 Fourth Ultimate Limit State (short term foundation sliding failure under EQ)</b>	<b>78</b>
3.3 Ultimate limit state bearing strength for shallow foundations	52	<b>C11.0 Fifth Ultimate Limit State (long term foundation bearing failure)</b>	<b>78</b>
3.4 Ultimate limit state sliding resistance	58	<b>C12.0 Sixth Ultimate Limit State (long term foundation sliding failure)</b>	<b>79</b>
3.5 Strength reduction factors	59	<b>C13.0 Comments</b>	<b>80</b>
<b>4.0 Pile Foundations</b>	<b>59</b>	<b>Acceptable Solution B1/AS4 Foundations</b>	<b>81</b>
4.1 Ultimate vertical strength of single piles	60	(Revised by Amendment 4)	
4.2 Column action	61		
4.3 Ultimate lateral strength of single piles	63	<b>Index</b>	<b>83</b>
4.4 Pile groups	66	(Revised by Amendment 4)	
4.5 Downdrag	66		
4.6 Ultimate lateral strength of pile groups	66		
4.7 Strength reduction factors	66		

Amend 4  
Dec 2000

Amend 4  
Dec 2000

Amend 4  
Dec 2000

Amend 4  
Dec 2000

# References (Revised by Amendment 4)

For the purposes of New Zealand Building Code compliance, the acceptable New Zealand and other Standards, and other documents referred to in this Compliance Document (primary reference documents) shall be the editions, along with their specific amendments, listed below. Where the primary reference documents refer to other Standards or other documents (secondary reference documents), which in turn may also refer to other Standards or other documents, and so on (lower order reference documents), then the applicable version of these secondary and lower order reference documents shall be the version in effect at the date this Compliance Document was published.

Amend 7  
Apr 2007

## Standards New Zealand

AS/NZS 1170: Structural design actions –

Part 0: 2002 General principles

*Amends: 1, 2, 4*

Part 1: 2002 Permanent imposed and other actions

*Amend: 1*

Part 2: 2002 Wind actions

*Amend: 1*

Part 3: 2003 Snow and ice actions

*Amend: 1*

NZS 1170: Structural design actions –  
Earthquake actions – New Zealand

## Where quoted

VM1 1.0, 2.0, 3.0,  
5.0, 6.0, 7.0,  
8.0, 12.0  
VM4 2.0, B1.0

VM1 1.0, 2.0, 3.0,  
5.0, 6.0, 7.0,  
8.0, 12.0

### COMMENT

The above suite of Structural Design Action Standards, together with their amendments, are referred to collectively in this *Verification Method* as “NZS 1170”.

Amend 8  
Dec 2008

AS/NZS 1664: Aluminium structures –  
Part 1: 1997 Limit state design  
*Amend: 1*

VM1 7.1

Amend 8  
Dec 2008  
Amend 9  
Sep 2010

AS/NZS 1748: 1997 Timber – Stress graded – Product requirements  
for mechanically stress-graded timber

VM1 6.1

AS/NZS 2032: 2006 Installation of PVC pipe systems  
*Amend: 1*

AS1 6.3

AS/NZS 2033: 2008 Installation of polyethylene pipe systems  
*Amends 1, 2*

AS1 6.4

AS/NZS 2566: 2002 Buried Flexible pipelines.

Part 1: 1998 Structural Design

AS1 6.1

Part 2: 2002 Installation

AS1 6.2

Amend 9  
Sep 2010

## STRUCTURE

			Where quoted
	AS/NZS 2918: 2001	Domestic solid fuel heating appliances installation	AS3 3.2.1, 2.2.4
Amend 9 Sep 2010	NZS 3101:- Part 1: 2006	Concrete structures standard The design of concrete structures <i>Amend: 1, 2</i>	VM1 3.1, 11.1
Amend 6 Mar 2005			
Amend 8 Dec 2008	NZS 3106: 2009	Design of concrete structures for the storage of liquids.	VM1 3.2
Amend 9 Sep 2010			
Amend 7 Apr 2007	NZS 3109: 1997	Concrete construction <i>Amend: 1, 2</i>	AS3 1.8.2, 1.8.5 b), 2.2.1 c), 2.2.3
Amend 9 Sep 2010	NZS 3112:- Part 2: 1986	Methods of test for concrete Tests relating to the determination of strength of concrete <i>Amend: 1, 2</i>	AS3 1.8.3 c)
Amend 9 Sep 2010			
	NZS 3404:- Part 1: 1997	Steel structures standard Steel structures standard <i>Amend: 1, 2</i>	VM1 5.1
Amend 9 Sep 2010			
Amend 9 Sep 2010	NZS 3601: 1973	Metric dimensions for timber <i>Amend: 1, 2</i>	AS2 1.0.4
Amend 7 Apr 2007	NZS 3603: 1993	Timber structures standard <i>Amend: 1, 2</i> (Applies to building work consented prior to 1 April 2007) <i>Amend: 1, 2, 4</i> (Applies to building work consented on or after 1 April 2007)	VM1 6.1, VM4 5.3.1
Amend 7 Apr 2007	NZS 3604: 1999	Timber framed buildings <i>Amend: 1</i> (Applies to building work consented prior to 1 April 2007) <i>Amend: 1, 2</i> (Applies to building work consented on or after 1 April 2007)	AS1 3.1, AS2 2.3.5, 2.3.6, AS3 1.1.1, 1.9.1 b), 1.9.2, 1.9.5, 2.2.1 b)
Amend 9 Sep 2010	NZS 3605: 2001	Timber piles and poles for use in building	VM4 5.3.1
Amend 7 Apr 2007	NZS 3622: 2004	Verification of timber properties <i>Amend: 1</i>	VM1 6.1
	NZS 3631: 1988	New Zealand national timber grading rules	AS2 1.0.3
Amend 9 Sep 2010	NZS 3640: 2003	Chemical preservation of round and sawn timber <i>Amend: 1, 2</i>	VM4 5.3.1, AS2 1.0.5 c)

		Where quoted
Amend 9 Sep 2010	AS/NZS 3725: 2007 Design for installation of buried concrete pipes	VM1 11.1
Amend 8 Dec 2008		
Amend 9 Sep 2010	AS/NZS 3869: 1999 Domestic solid fuel burning appliances – Design and construction	AS3 2.1
	AS/NZS 4058: 2007 Pre cast concrete pipes(pressure and non-pressure)	VM1 11.1
Amend 9 Sep 2010	NZS 4210: 2001 Code of practice for masonry construction: materials and workmanship <i>Amend: 1</i>	AS3 1.8.1, 1.8.3 f) and g)
	NZS 4211: 1985 Specification for performance of windows <i>Amend: 1, 2, 3</i>	VM1 12.1
Amend 8 Dec 2008		
Amend 9 Sep 2010	NZS 4223:- Part 1: 2008 Glazing in buildings Glass selection and glazing	AS1 7.1
	Part 2: 1985 The selection and installation of manufactured sealed insulating glass units <i>Amend: 1, 2</i>	AS1 7.2
Amend 9 Sep 2010	Part 3: 1999 Human impact safety requirements	AS1 7.3
	Part 4: 2008 Wind, dead, snow, and live actions	AS1 7.4
	NZS 4229: 1999 Concrete masonry buildings not requiring specific engineering design <i>Amend: 1</i>	AS1 2.1, AS3 1.1.1, 1.8.4, 1.9.2, 1.9.5, 2.2.1 b)
Amend 8 Dec 2008	NZS 4230: 2004 Design of reinforced concrete masonry structures <i>Amend: 1</i>	VM1 4.0
	NZS 4251:- Part 1: 1998 Solid plastering Cement plasters for walls, ceilings and soffits	AS1 5.1
	NZS 4297: 1998 Engineering design of earth buildings	VM1 8.1
	NZS 4299: 1998 Earth buildings not requiring specific design <i>Amend: 1</i>	AS1 4.1
	NZS 4402:- Part 2: Methods of testing soils for civil engineering purposes. Parts 2, 4 and 5:1986 and 1988 Soil classification tests	VM1 11.1
	Test 2.2: 1986 Determination of liquid limit	Definitions
	Test 2.6: 1986 Determination of the linear shrinkage	Definitions
	Part 4: Soil compaction tests	
	Test 4.2.3: 1988 Relative densities	VM4 4.1.1

		Where quoted
	NZS 4431: 1989 Code of practice for earth fill for residential development <i>Amend: 1</i>	VM1 10.1
	AS/NZS 4600: 2005 Cold-formed steel structures	VM1 5.2
	AS/NZS 4671: 2001 Steel Reinforcing Materials <i>Amend: 1</i>	AS1 1.8.5
	AS/NZS 4680: 2006 Hot-Dip Galvanised (zinc) Coating	AS2 1.0.5 b), AS3 1.8.6
Amend 9 Sep 2010		
Amend 8 Dec 2008	SNZ HB 8630: 2004 Tracks and outdoor visitor structures	VM1 2.2.9
	<b>British Standards Institution</b>	
	BS 8004: 1986 Code of practice for foundations	VM4 4.0.3
	<b>Standards Australia</b>	
Amend 9 Sep 2010	AS 1397: 2001 Steel sheet and strip – Hot-dipped zinc-coated or aluminium/zinc-coated	AS2 1.0.5 c) AS3 1.7.9
	AS 1214: 1983 Hot-dip galvanised coatings on threaded fasteners (ISO metric coarse thread series)	AS2 1.0.5 b)
	AS 2159: 1995 Rules for the design and installation of piling (known as the SAA Piling Code) <i>Amend: 1</i>	VM4 4.0.3
	<b>American Society of Testing and Materials</b>	
	ASTM D1143: 1981 Test method for piles under static axial compressive load	VM4 4.0.3
	<b>New Zealand Geomechanics Society</b>	
	Guidelines for the field descriptions of soils and rocks in engineering use. Nov 1988	VM1 11.1
	<b>New Zealand Legislation</b>	
Amend 8 Dec 2008	Chartered Professional Engineers of New Zealand Act 2002	VM1 1.0
	<b>Transit New Zealand</b>	
	Bridge manual: Design and evaluation: 1994 <i>Amend: 1</i>	VM1 11.1

# Definitions

This is an abbreviated list of definitions for words or terms particularly relevant to this Compliance Document. The definitions for any other italicised words may be found in the New Zealand Building Code Handbook.

Amend 7  
Apr 2007

**Adequate** *Adequate* to achieve the objectives of the *Building Code*.

Amend 8  
Dec 2008

**Alter** in relation to a *building*, includes to rebuild, re-erect, repair, enlarge and extend the *building*.

**Baluster** A post providing the support for the top and bottom rails of a barrier.

**Boundary joist** A joist running along the outer ends of the floor joists.

Amend 7  
Apr 2007

**Building** has the meaning ascribed to it by sections 8 and 9 of the Building Act 2004.

**Building element** Any structural and non-structural component or assembly incorporated into or associated with a *building*. Included are *fixtures*, services, *drains*, permanent mechanical installations for access, glazing, partitions, ceilings and temporary supports.

**Chimney** A *non-combustible* structure which encloses one or more *flues*, *fireplaces* or other heating appliances.

**Chimney back** The *non-combustible* wall forming the back of a *fireplace*.

**Chimney base** That part of a *chimney* which houses the *fireplace*.

**Chimney jambs** The side walls of a *fireplace*.

**Combustible** See *non-combustible*.

Amend 8  
Dec 2008

**Construct** in relation to a *building*, includes to design, build, erect, prefabricate, and relocate the *building*.

**Drain** A pipe normally laid below ground level including fittings and equipment and intended to convey *foul water* or *surface water* to an *outfall*.

**Factor of safety** in relation to any *building* means the ratio of resisting forces to applied forces for a given loading condition. It is generally expressed to two significant figures.

**Fireplace** A space formed by the *chimney back*, the *chimney jambs*, and the *chimney breast* in which fuel is burned for the purpose of heating the room into which it opens.

**Fixture** An article intended to remain permanently attached to and form part of a *building*.

**Flue** The passage through which the products of combustion are conveyed to the outside.

**Gather** That part of a *chimney* where the transition from *fireplace* to stack occurs.

**Good ground** means any soil or rock capable of permanently withstanding an ultimate bearing pressure of 300 kPa (i.e. an allowable bearing pressure of 100 kPa using a factor of safety of 3.0), but excludes:

- a) Potentially compressible ground such as topsoil, soft soils such as clay which can be moulded easily in the fingers, and uncompacted loose gravel which contains obvious voids,
- b) Expansive soils being those that have a liquid limit of more than 50% when tested in accordance with NZS 4402 Test 2.2, and a linear shrinkage of more than 15% when tested, from the liquid limit, in accordance with NZS 4402 Test 2.6, and
- c) Any ground which could foreseeably experience movement of 25 mm or greater for any reason including one or a combination of: land instability, ground creep, subsidence, seasonal swelling and shrinking, frost heave, changing ground water level, erosion, dissolution of soil in water, and effects of tree roots.

Amend 4  
Dec 2000

**COMMENT:**

Soils (excepting those described in a), b) and c) above) tested with a dynamic cone penetrometer in accordance with NZS 4402 Test 6.5.2, shall be acceptable as good ground for *building* foundations if penetration resistance is no less than:

- a) 3 blows per 75 mm at depths no greater than the footing width.
- b) 2 blows per 75 mm at depths greater than the footing width.

Depths shall be measured from the underside of the proposed footing.

Amend 4  
Dec 2000

**Hearth** The insulating floor under the *fire* and in front and at the sides of the *fireplace*.

**Intended use**, in relation to a *building*:

- a) includes any or all of the following:
  - i) any reasonably foreseeable occasional use that is not incompatible with the *intended use*;
  - ii) normal maintenance;
  - iii) activities undertaken in response to *fire* or any other reasonably foreseeable emergency; but
- b) does not include any other maintenance and repairs or rebuilding.

**Nominal pile width** The least width of a pile in side view and is equal to the diameter in round piles.

**Non-combustible** Materials shall be classified as *non-combustible* or *combustible* when tested to: AS 1530 – Part 1.

**Other property**

- a) means any land or *buildings*, or part of any land or *buildings*, that are—
  - i) not held under the same *allotment*; or
  - ii) not held under the same ownership; and
- b) includes a road

**Sitework** means work on a *building* site, including earthworks, preparatory to or associated with the *construction, alteration, demolition* or removal of a *building*.

**Specified intended life** has the meaning given to it by section 113(3) of the Building Act 2004.

Section 113(3) states:

“(3) In subsection (2), **specified intended life**, in relation to a building, means the period of time, as stated in an application for a building consent or in the consent itself, for which the building is proposed to be used for its intended use.”

**Strength reduction factor** The factor by which the ultimate strength is multiplied to obtain the design strength.

**COMMENT:**

NZS 4203: 1992 uses the terms ideal strength in place of ultimate strength, and dependable strength in place of design strength.

**Surface water** All naturally occurring water, other than sub-surface water, which results from rainfall on the site or water flowing onto the site, including that flowing from a *drain*, stream, river, lake or sea.

**Territorial authority (TA)** means a city council or district council named in Part 2 of Schedule 2 of the Local Government Act 2002; and—

- a) in relation to land within the district of a *territorial authority*, or a *building* on or proposed to be built on any such land, means that *territorial authority*; and
- b) in relation to any part of a coastal marine area (within the meaning of the Resource Management Act 1991) that is not within the district of a *territorial authority*, or a *building* on or proposed to be built on any such part, means the *territorial authority* whose district is adjacent to that part.

**Verification Method** means a method by which compliance with the *Building Code* may be verified.

Amend 7  
Apr 2007

Amend 7  
Apr 2007

Amend 8  
Dec 2008

Amend 8  
Dec 2008

Amend 2  
Aug 1994

Amend 8  
Dec 2008



# Verification Method B1/VM1 General

(Revised by Amendment 4)

## 1.0 General

**1.0.1** The Standards cited in this *Verification Method* provide a means for the design of structures to meet the performance requirements of New Zealand Building Code Clause B1 Structure. For any particular *building* or *building* design, the *Verification Method* shall consist of NZS 1170 used in conjunction with the relevant cited material standards as modified by this *Verification Method*.

**1.0.2** Modifications to the Standards, necessary for compliance with the New Zealand *Building Code*, are given against the relevant clause number of each Standard.

**1.0.3** Citation of Standards in this *Verification Method* is subject to the following conditions.

- a) The citation covers only the scope stated or implicit in each Standard. Aspects outside the scope, when applied to a particular *building*, are not part of the *Verification Method*.
- b) Further limitations, modifications and/or constraints apply to each Standard as noted below.
- c) Provisions in the cited Standards that are in non-specific or unquantified terms do not form part of the *Verification Method*. Non-specific or unquantified terms include, but are not limited to, special studies, manufacturer's advice and references to methods that are appropriate, adequate, suitable, relevant, satisfactory, acceptable, applicable, or the like.
- d) Where NZS 1170 is used in combination with other Standards cited in this *Verification Method* and there are incompatibilities with these other Standards, then the underlying philosophy, general approach, currency of information and methods of NZS 1170 are to take precedence.

- e) An engineer with relevant experience and skills in structural engineering shall be responsible for interpretation of the requirements of the Standards cited when used for *building* structure design. A structural engineer who is chartered under the Chartered Professional Engineers of New Zealand Act 2002 would satisfy this requirement.

### COMMENT

The Standards referenced in this *Verification Method* relating to *building* design require the application of specialist engineering knowledge, experience and judgement in their use.

## 2.0 Structural Design Actions Standards

**2.1** The requirements of the AS/NZS 1170 suite of Standards are to be complied with. These comprise:

AS/NZS 1170.0: 2002 including Amendments 1, 2 and 4,

AS/NZS 1170.1: 2002 including Amendment 1,  
AS/NZS 1170.2: 2002 including Amendment 1,  
AS/NZS 1170.3: 2003 including Amendment 1,  
and NZS 1170.5: 2004.

### COMMENT

This suite of Standards, together with their amendments, are referred to collectively in this *Verification Method* as "NZS 1170".

**2.2** The requirements of NZS 1170 are subject to the following modifications.

**2.2.1 Material Standards** Where NZS 1170 calls for the use of appropriate material Standards, only those material Standards referenced in this *Verification Method* B1/VM1 are included. Use of other Standards with NZS 1170 must be treated as an alternative means of verification.

**2.2.2 Notes in NZS 1170** “Notes” that relate to clauses, tables or figures of NZS 1170 are part of the *Verification Method*.

**COMMENT**

NZS 1170 makes a general statement that notes are not an integral part of the Standard. However, in many cases the content of the notes makes them an integral part of the interpretation of the Standard. In these cases, the notes have been specifically cited as being part of this *Verification Method*.

**2.2.3 AS/NZS 1170 Part 0, Clause 4.1**

**General** Add the following to the end of the Clause:

“The combination factors for permanent actions (dead loads) are based on the assumption that they have a coefficient of variation of approximately 10%. Situations where this assumption is not valid are outside the scope of this *Verification Method*.”

**2.2.4 AS/NZS 1170 Part 0, Clause 4.2.4**

Replace the Clause with the following:

“The combination of actions for checking strength and stability for the ultimate limit state for *fire* shall be as follows:

(a) During the *fire*:

(i) [G, thermal actions arising from *fire*,  $\Psi_f Q$ ]

together with:

(ii) a lateral force of 2.5% of  $(G + \Psi_c Q)$  applied as per Clause 6.2.2.

(b) After the *fire* until the *building* is either repaired or demolished:

(i) [G, thermal actions arising from *fire*,  $\Psi_f Q$ ]

together with the more critical of either:

(ii) a lateral force of 2.5% of  $(G + \Psi_c Q)$  applied as per Clause 6.2.2.

or

(iii) a uniformly distributed horizontal face load of 0.5 kPa in any direction.

Account shall be taken of the effects of the *fire* on material properties and the geometry of the structure.”

**2.2.5 AS/NZS 1170 Part 0, Clause 5.2**

**Structural models** Delete (a) to (d) in Clause 5.2 and replace with:

“(a) Static **and**/or dynamic response.

(b) Elastic **and**/or non-elastic (plastic) response.

(c) Geometrically linear **and**/or geometrically non-linear response.

(d) Time-independent **and**/or time-dependent behaviour.”

**COMMENT**

Each of the modelling approaches (a), (b), (c) and (d) allows only one method. This is unnecessarily restrictive since designers may decide to use both approaches for a particular *building*. Accordingly, “or” has been replaced with “and/or”.

**2.2.6 AS/NZS 1170 Part 1, Table 3.2**

Replace the entry for “R2, Other roofs (i) Structural elements” with:

“R2 Other roofs (i) Structural elements 0.25 1.1 (See Note 1)”

**2.2.7 AS/NZS 1170 Part 1, Clause 3.6 Barriers**

In the first paragraph, second sentence, delete “... top edge or handrail...” and substitute “... top edge **and rail**...”

Delete the second paragraph and substitute:

“Apply as detailed below the uniformly distributed line loads (kN/m), uniformly distributed loads (kPa) and concentrated loads (kN) given in Table 3.3.

For the purposes of applying loads, a rail shall be any *handrail* or any top rail having a width in plan of greater than 30 mm.

The following are separate load cases, and one load at a time, either vertical or horizontal, is to be applied.

(a) Line loads (kN/m). Regardless of barrier height, line loads need not be applied more than 1200 mm above the floor (or stair pitch line):

(i) For domestic and residential activities, other residential (Row 2 of Table 3.3)

- For barriers with a rail or rails:

- apply the horizontal load to the top rail

- where the top of the barrier is not a rail and where it is less than 200 mm above the top rail, the horizontal load to the top of the barrier may be reduced by 50%, otherwise apply the full horizontal load
  - apply the vertical load to the top of the barrier.
  - For barriers without a rail, apply:
    - the horizontal load at 900 mm above the floor (or stair pitch line)
    - 50% of the horizontal load to the top of the barrier
    - the vertical load to the top of the barrier.
- (ii) For all types of occupancy other than Row 2 of Table 3.3:
- apply the loads to the top edge of the barrier and to the top rail
  - where the top of the barrier is not a rail and where it is less than 200 mm above the top rail, the horizontal load to the top of the barrier may be reduced by 50%, otherwise apply the full horizontal load.
- (b) Distributed loads (kPa):
- For all types of occupancy:
- consider the load as acting over the whole area bounded by the top of the barrier and the floor line for the full length of the barrier
  - distribute this load to the appropriate solid portions of the barrier.
- (c) Concentrated loads (kN):
- For all types of occupancy:
- consider each concentrated load to be distributed over a circular or square area of 2000 mm<sup>2</sup>
  - apply concentrated loads so as to produce the most severe effect on the structural element being considered

- concentrated loads applied more than 1200 mm above the floor (or stair pitch line) may be reduced by 50%
- where the barrier infill or *balustrade* consists of parallel vertical members, less than 100 mm wide and with spaces between them of less than 100 mm, 50% of the concentrated load may be applied to each vertical member."

**COMMENT**

In Table 3.3, "external balconies" for domestic and residential activities applies to decks, balconies, verandahs and the like of individual houses as well as multi household unit buildings. Such barriers may be required by Clause F4 of the *Building Code*.

**2.2.8 AS/NZS 1170 Part 1, Clause 3.8**

**Car park** Add to the last paragraph of Clause 3.8:

"The basis for determining the horizontal impact actions on barriers quoted in the Clause, including the assumed deceleration distances, is given in Clause C 3.8 of the Commentary to AS/NZS 1170 Part 1. Different design actions may be derived using Equation C3.8, provided that:

- (i) The deceleration length applied is based on analysis or tests.
- (ii) The vehicle mass and associated velocity are not reduced from those quoted in Commentary Clause C3.8."

**2.2.9 AS/NZS 1170 Part 1, Appendix B**

Replace the last paragraph with the following:

"For the design of outdoor visitor structures as defined in SNZ HB 8630: 2004, the imposed actions must be as given by that publication with references to NZS 4203 replaced by equivalent references to NZS 1170."

**2.2.10 AS/NZS 1170 Part 2, Clauses 3.2 and 4.4.3**

Add the following at the end of Clauses 3.2 and 4.4.3:

"Where local wind design information is more onerous than determined by this Standard and is published and required to be used by any *territorial authority* for its area, this local wind design information shall take precedence over

the equivalent information in this Standard for the determination of wind actions on *buildings*.

Where such local wind design information is less onerous than that of this Standard, the use of such information is not part of this *Verification Method*."

**2.2.11 AS/NZS 1170 Part 2, Clause 4.3.1**

**General** Add the following to the end of Clause 4.3.1:

"Account must be taken of combinations of isolated tall *buildings* placed together that lead to local and overall increases in wind."

**2.2.12 AS/NZS 1170 Part 3, Clause 2.1**

Add the following at the end of Clause 2.1:

"Where local snow and ice design information is more onerous than determined by this Standard and is published by any *territorial authority* for its area, this local snow and ice design information shall take precedence over the equivalent information in this Standard for the determination of snow and ice actions on *buildings*.

Where such local snow and ice design information is less onerous than that of this Standard, the use of such information is not part of this *Verification Method*."

**2.2.13 AS/NZS 1170 Part 3, Clause 5.4.3**

Add the following to end of Clause 5.4.3:

"For Regions N4 and N5 the minimum value of  $s_g$  for the ultimate limit state only must be taken as 0.9 kPa."

**2.2.14 NZS 1170 Part 5, Clause 1.4**

Add the following to the end of the Clause 1.4:

"Where a special study yields a site-specific uniform risk design spectrum for 500 year return period equivalent to a hazard factor,  $Z$ , of less than 0.08, a design spectrum equivalent to at least  $Z = 0.10$  may be adopted and the minimum magnitude 6.5 earthquake need not be considered.

**COMMENT:**

In areas where the uniform risk hazard factor is less than 0.08, the use of a minimum hazard factor  $Z = 0.13$  implies design for earthquakes with extremely low probabilities of occurrence. For some projects in these areas this may involve considerable cost consequences and a reduction in requirements is acceptable when site-specific hazard studies are undertaken."

**2.2.15 NZS 1170 Part 5, Clause 4.2 Seismic weight and seismic mass**

After: "0.3 is the earthquake imposed action (live load) combination factor for all other applications" add the following:

"except roofs.

$\Psi_E = 0.0$  is the earthquake imposed action (live load) combination factor for roofs."

**2.2.16 NZS 1170 Part 5, Sections 5 and 6**

**Time history analysis** Time history analysis is not part of this *Verification Method*.

**COMMENT:**

Time history analysis is a highly specialised method of assessing structural response to earthquakes. It requires many detailed and interdependent assumptions to be made in relation to the nature of earthquake shaking and its propagation from the source, the properties of the *building* site and the detailed characteristics of the *building* and its structural elements.

AS/NZS 1170 outlines the steps for time history analysis in some detail, but the applicability of each step needs to be evaluated on a *building-by-building* basis. More importantly, the output of the analysis needs to be examined carefully in each particular context.

Time history analysis can be an acceptable aid to verifying compliance with structural requirements provided that:

- It is carried out by specialists with in-depth experience in applying the technique.
- The output of the analysis and the viability of the resulting structural design are reviewed by an independent team experienced in both analysis and design.

**2.2.17 NZS 1170 Part 5, Clause 5.2.2.3,**

**equation 5.2(4)** Delete equation 5.2(4)

and replace with:

$$C_d(T) = \frac{C(T) S_p}{k_\mu} \quad \dots \text{5.2(4)}$$

**2.2.18 NZS 1170 Part 5, Clause 6.1.4.1**

**Requirement for modelling** Delete the

last sentence of the first paragraph and replace with:

"The model shall include representation of the diaphragm's flexibility."

Delete the third (last) paragraph.

Amend 9  
Sep 2010

Amend 8  
Dec 2008

Amend 8  
Dec 2008

### 3.0 Concrete

**3.1 NZS 3101: Part 1** subject to the following modifications:

a) Replace clause 4.8 **External walls that could collapse outward in fire** with:

#### **4.8 External walls that could collapse inwards or outwards in fire**

##### **4.8.1 Application**

This clause applies to external walls which could collapse inwards or outwards from a building as a result of internal fire exposure. All such walls shall:

- (a) Be attached to the building structure by steel connections;
- (b) Be restrained by these connections, when subject to fire, from inwards or outward movement of the wall relative to the building structure; and
- (c) Comply with the appropriate provisions of this Standard for walls.

##### **4.8.2 Forces on connections**

The connections between each wall and the supporting structure shall be designed to resist all anticipated forces. In the absence of a detailed analysis, the connections shall be designed to resist the largest of:

- (a) The force resulting from applying Clause 2.2.4 of Verification Method B1/VM1;
  - (b) for walls fixed to a flexible structure of unprotected steel, the force required to develop the nominal flexural strength of the wall at its base;
  - (c) for walls fixed to a rigid structure such as reinforced concrete columns or protected steel columns or another wall at right angles, the force required to develop the nominal flexural strength of the wall at mid-height.
- b) Amend Clause **9.3.9.4.13 Minimum area of shear reinforcement**

In Clause 9.3.9.4.13 c) delete the words after "750 mm" and substitute "and the depth of the precast unit is equal to or less than 300 mm."

Amend 9  
Sep 2010

c) Amend Clause **18.7.4 Floor or roof members supported by bearing on a seating**

Add to the end of Clause 18.7.4 (g)(ii) add an additional sentence:

"The details given by C18.6.7(e) may be applied to hollow-core units where the depth of the precast unit is equal to or less than 300 mm."

Erratum 1  
Sep 2010

### 3.2 NZS 3106

Amend 9  
Sep 2010

### 4.0 Concrete Masonry

#### 4.1 NZS 4230

Amend 8  
Dec 2008

### 5.0 Steel

#### 5.1 NZS 3404: Part 1

Amend 9  
Sep 2010  
Amend 8  
Dec 2008

**5.2 AS/NZS 4600** subject to the following modifications:

- a) Actions must be determined in accordance with NZS 1170. All references to NZS 4203 are replaced by equivalent references to NZS 1170.
- b) The term "normative" identifies a mandatory requirement for compliance with this Standard.
- c) The term "informative" identifies information provided for guidance or background which may be of interest to the Standard's users. Informative provisions do not form part of the mandatory requirements of the Standard.
- d) Where this Standard has provisions that are in non-specific or unquantified terms then these do not form part of the *Verification Method* and the proposed details must be submitted to the *territorial authority* for approval as part of the *building consent* application. This includes, but is not limited to, special studies and manufacturer's advice.
- e) All stages of *construction* of a structure or part of a structure to which this Standard is applied shall be adequately reviewed by a person who, on the basis of experience or qualifications, is competent to undertake the review.

Amend 8  
Dec 2008



- f) The extent of the review to be undertaken shall be nominated by the design engineer, taking into account those materials and workmanship factors which are likely to influence the ability of the finished construction to perform in the predicted manner.
- g) At the end of the first paragraph of Appendix A add the words "Unless noted otherwise a document referred to below shall be the version of that document current at the date of issue of this Standard or if amendments are cited to this Standard in the "References" pages of *Compliance Document B1* at the latest date of those amendments."
- h) Appendix B shall be read as normative with "shoulds" changed to "shalls".

are in non-specific or unquantified terms then these do not form part of the *Verification Method* and the proposed details must be submitted to the *territorial authority* for approval as part of the *building consent* application. This includes, but is not limited to, special studies and manufacturer's advice.

- d) All stages of *construction* of a structure or part of a structure to which this Standard is applied shall be adequately reviewed by a person who, on the basis of experience or qualifications, is competent to undertake the review.
- e) The extent of the review to be undertaken shall be nominated by the design engineer, taking into account those materials and workmanship factors which are likely to influence the ability of the finished *construction* to perform in the predicted manner.

Amend 8  
Dec 2008

Amend 8  
Dec 2008

## 6.0 Timber

**6.1 NZS 3603** subject to the following modifications:

- a) Actions must be determined in accordance with NZS 1170. All references to NZS 4203 are replaced by equivalent references to NZS 1170.
- b) Delete Clause 2.2.1.2 and replace with:  
"Machine stress-grading shall be in accordance with AS/NZS 1748 as modified by NZS 3622. Machine stress-graded timber shall have its properties verified, and be identified, in accordance with the requirements of NZS 3622."

- f) Clause 1.2 to read "**MATERIALS** This Standard applies to aluminium alloys listed in Table 3.3(A) that comply with AS 1734, AS 1865, AS 1866, AS 1867 and AS 2748.1."

- g) At the end of the first paragraph of Clause 1.4 add the words "Unless noted otherwise a document referred to below shall be the version of that document current at the date of issue of this Standard or if amendments are cited to this Standard in the "References" pages of *Compliance Document B1* at the latest date of those amendments."

Amend 8  
Dec 2008

Amend 7  
Apr 2007

Amend 8  
Dec 2008

## 7.0 Aluminium

**7.1 AS/NZS 1664.1** subject to the following modifications:

- a) Actions must be determined in accordance with NZS 1170. All references to NZS 4203 are replaced by equivalent references to NZS 1170.
- b) The terms "capacity factor" and "strength limit state" are to be read as "*strength reduction factor*" and "*ultimate limit state*" respectively.
- c) Where this Standard has provisions that

## 8.0 Earth Buildings

**8.1 NZS 4297** subject to the following modifications:

Actions must be determined in accordance with NZS 1170. All references to NZS 4203 are replaced by equivalent references to NZS 1170.

## 9.0 Foundations

See B1/VM4 of this *Compliance Document*.

Amend 8  
Dec 2008

## 10.0 Siteworks

---

### 10.1 NZS 4431

## 11.0 Drains

---

**11.1 AS/NZS 3725** subject to the following modifications:

**Clause 3** Add to the list of reference documents:

“NZS 3101 The design of concrete structures.

NZS 4402 Methods of testing soils for civil engineering purposes: Tests 2.4, 2.8, 4.1.1, 4.2.1, 4.2.2, 4.2.3 and 5.1.1.

New Zealand Geomechanics Society,  
Guidelines for the field description of soils and rocks in engineering use.”

**Clause 4** In the paragraph headed “(c) Select fill”, after the words “given in Table 1” add “or the New Zealand Geomechanics Society Guidelines”.

**Clause 5** In definition of Pt, replace “AS 4058” with “AS/NZS 4058”

**Clause 6.4** Replace the word “may” with “shall”. Delete the words “Superimposed concentrated dead loads should be avoided.”

**Clause 6.5.3.1** Delete the words “The appropriate road vehicle loading shall be specified by the relevant highway authority or owner”.

**Clause 6.5.3.2.2** Replace the word “may” with “shall”.

**Clause 6.5.4.3** Delete the words “unless otherwise specified by the Relevant Authority”.

**Clause 6.5.5** Delete the first words “For” and after the words “for aircraft types” add the words “is outside the scope of this Standard but...”

**Clause 7** Replace the word “should” with “shall”.

**Clause 10.3** After the words “the test load” add “or proof load”.

**Appendix A** Delete “Normative” and replace with “Informative”

**Appendix B** Delete “Normative” and replace with “Informative”

## 12.0 Windows

---

**12.1 NZS 4211** subject to the following modifications:

- a) References to air leakage, water leakage and operational effectiveness of opening sashes in NZS 4211, are non-structural considerations and do not apply to this *Compliance Document*. The more substantial of such references are listed in Amendment No 2, July 1992.
- b) Where wind and other loads used are required by NZS 4211 to be determined in accordance with NZS 4203, they must be determined in accordance with NZS 1170. All other references to NZS 4203 are replaced by equivalent references to NZS 1170.



# Acceptable Solution B1/AS1

## General (Revised by Amendment 4)

### 1.0 Explanatory Note

---

**1.1** This part of the Approved Document lists under category headings other Approved Documents and Standards, suitable as acceptable solutions.

**1.2** In other parts of this Approved Document acceptable solutions are given for small *chimneys* and timber barriers. These are referred to in Paragraphs 8.0 and 9.0 respectively.

**1.3** Modifications to the Standards, necessary for compliance with the New Zealand Building Code, are given against the relevant clause number of each Standard.

### 2.0 Masonry

---

#### 2.1 NZS 4229

### 3.0 Timber

---

#### 3.1 NZS 3604

### 4.0 Earth Buildings

---

#### 4.1 NZS 4299

### 5.0 Stucco

---

#### 5.1 NZS 4251

### 6.0 Drains

---

#### 6.1 AS/NZS 2566.1

#### 6.2 AS/NZS 2566.2

#### 6.3 AS/NZS 2032

#### 6.4 AS/NZS 2033

**8.0 Small Chimneys**

---

See B1/AS3 of this Approved Document.

**9.0 Timber Barriers**

---

See B1/AS2 of this Approved Document.

**7.0 Glazing**

---

**7.1 NZS 4223.1** subject to the following modifications:

**Clause 1.2(e)** Reword to read:

“For framed, unframed, and partly framed glass assemblies in buildings up to 10m high glass shall be selected in accordance with section 5.”

**7.2 NZS 4223.2**

**7.3 NZS 4223.3**

**7.4 NZS 4223.4**

Amend 9  
Sep 2010

# Verification Method B1/VM2

## Timber Barriers

No specific test methods have been adopted for verifying compliance of timber barriers with NZBC Performance B1.



# Acceptable Solution B1/AS2 Timber Barriers

## 1.0 Scope

**1.0.1** This document applies to the *construction* of timber barriers for *Housing*. The solution described will have an expected life of 15 years.

**COMMENT:**

The 15 year life is based on the life expectancy of the nail plates and the circular tooth plate connectors described in this acceptable solution. These connectors can be fabricated from thicker steel, have different coatings or be made from other materials such as stainless steel, to give the barrier a greater life. If, however, a greater life is claimed it must be substantiated by supporting information.

Amend 1  
Sep 1993

**1.0.2** Barriers complying with this document, satisfy NZBC F4 for the protection of children under the age of six years.

**1.0.3** Timber used in the *construction* of the timber barriers shall be No. 1 framing grade Radiata Pine as specified in NZS 3631.

**1.0.4** Cross-sectional dimensions of timber given in this document are call dimensions as specified in NZS 3601, unless otherwise noted.

**COMMENT:**

Actual timber dimensions will vary according to moisture content and level of finish e.g. roughsawn, gauged or dressed.

**1.0.5** Barriers exposed to the weather shall have:

a) All timber treated to at least hazard class H3 in accordance with NZS 3640.

b) Mild steel fixings hot-dip galvanised as specified in AS/NZS 4680 for nails, and AS 1214 for bolts and coach screws.

c) Circular toothed plate connectors and nail plates, where required by this document, that are formed from 1.0 mm thick sheet mild steel with a zinc coating of at least 275 g/m<sup>2</sup> in accordance with AS 1397.

Amend 9  
Sep 2010

Amend 9  
Sep 2010  
Amend 1  
Sep 1993

Amend 9  
Sep 2010 | Amend 1  
Sep 1993

## 2.0 Construction

### 2.1 General

**2.1.1** Barriers shall comprise *balusters*, top and bottom rails, and palings. The supporting floor shall have joists no less in size than 125 mm x 50 mm. Where a *boundary joist* or blocking is used it shall have the same cross section as the joists.

### 2.2 Top rails

**2.2.1** Top rails shall be Type 1 or Type 2 as shown in Figure 1. The size of the top rail depends on its span between *balusters* and is given in Table 1.

**2.2.2** Top rails shall be fixed to each *baluster* with nails having a shank diameter of no less than 3.75 mm and penetrating the *baluster* by no less than 50 mm. The number of nails for each fixing shall be:

- 2 for spans up to and including 1400 mm
- 3 for spans greater than 1400 mm

### 2.3 Balusters

**2.3.1** *Baluster* size depends on the type and span of the top rail and shall be as given in Table 2.

**Table 1: Top Rail Sizes – Type 1 and Type 2**  
Paragraph 2.2.1 and Figures 1 and 3

	Maximum spacing (c-c) of balusters for top rail (mm)	Size of top rail (mm)
<b>Type 1:</b>	1000	75 x 50
	1500	100 x 50
	1800	125 x 50
	2000	150 x 50
<b>Type 2:</b>	1000	75 x 50
	1400	100 x 50
	1500	125 x 50
	1600	150 x 50
	1700	200 x 50
	1800	225 x 50

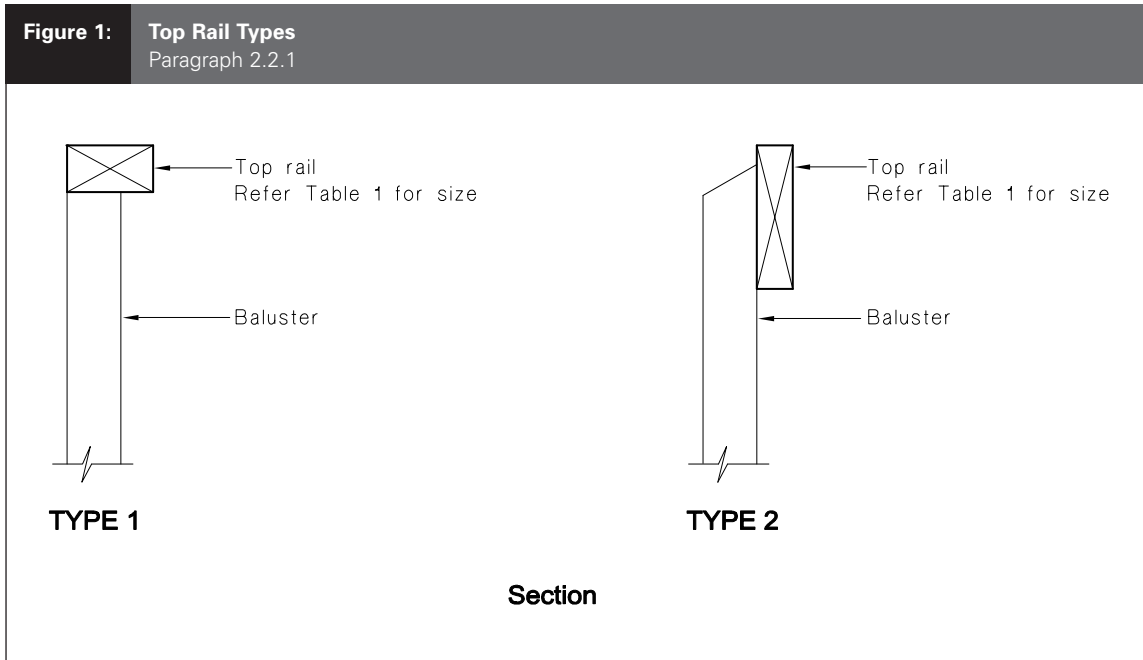
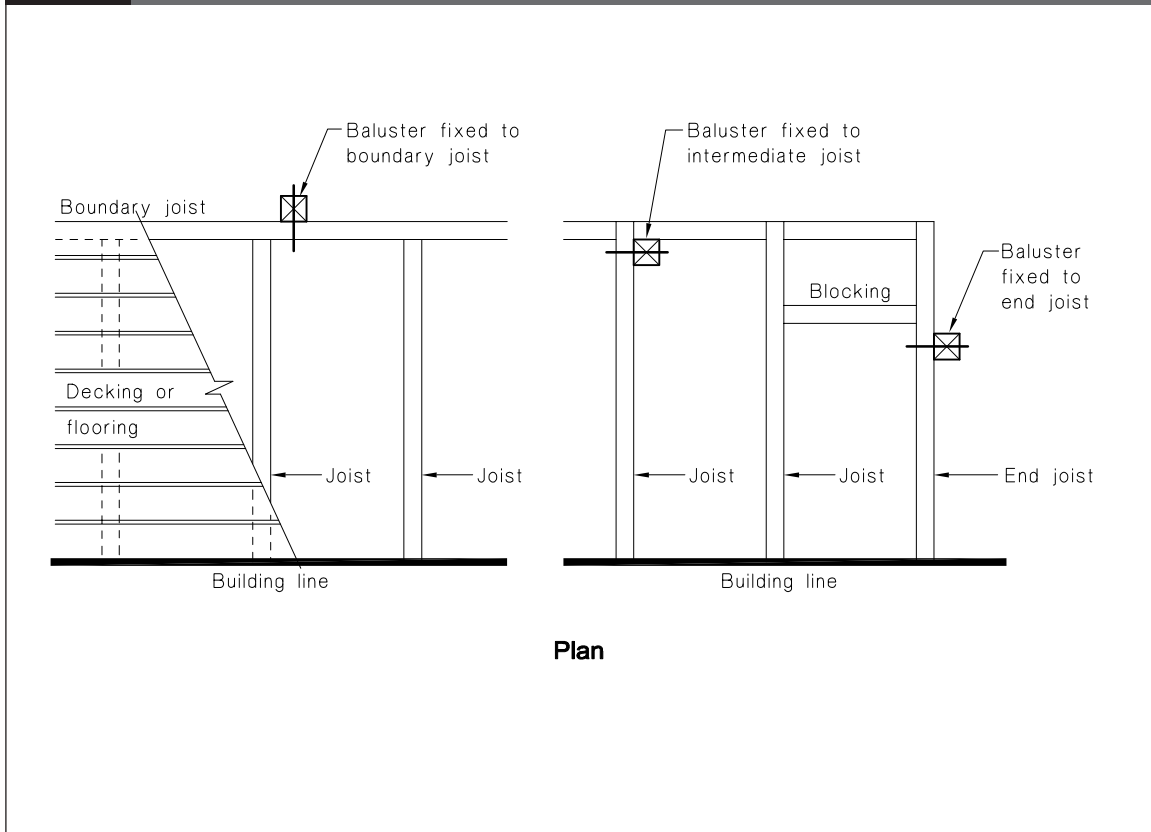

**Table 2: Baluster Sizes**  
Paragraph 2.3.1 and Figures 3 and 4

Baluster size (mm)	Maximum baluster spacing (c-c) for top rail (mm)	
	Type 1	Type 2
50 x 100	400	40
75 x 50	600	600
75 x 75	800	800
100 x 50	1200	1200
75 x 100	1200	1200
100 x 75	1800	1700
100 x 100	2000	1800

**Note:**  
The first dimension given for the *baluster* is the depth measured perpendicular to the line of the top rail as shown in Figures 3 and 4.

**Figure 2: Fixing Positions for Balusters**  
Paragraph 2.3.2



Plan

**2.3.2** *Balusters* can be fixed to an intermediate joist, end joist or to a *boundary joist*. The three situations are shown in Figure 2, and the corresponding fixing details are shown in Figures 3 and 4.

**2.3.3** Where a *baluster* is fixed to an intermediate joist, its fixings depends on the *baluster* spacing and the depth of the joist, and shall comprise either of M12 bolts or M12 bolts with double sided circular toothed plate connectors, as determined from Table 3.

**2.3.4** Where a *baluster* is fixed to an end joist or a *boundary joist*, it shall be fixed with two M12 bolts in all situations, and the *baluster* shall be no further than 85 mm from the required blocking or adjacent joist as shown in Figure 4.

**2.3.5** *Boundary joists* shall be fixed to each joist adjacent to a *baluster* with two 12 mm diameter coach screws, and with two nail plates (one at the top and one at the bottom) as shown in Figure 4. Coach screws shall have a minimum penetration of 100 mm and shall have a 50 x 50 x 3 mm washer. Nail plates shall comply with Paragraph 1.0.5 c) and shall be capable of carrying a tension force of 4.0 kN (capacity load as defined in NZS 3604). The *boundary joist* shall be fixed to all other joists with three nails of 3.75 mm shank diameter, penetrating 50 mm into the joist.

See Comment page 28.

Amend 2  
Aug 1994

Amend 1  
Sep 1993

**Figure 3: Baluster Fixed to Intermediate Joist**  
Paragraphs 2.3.2, 2.4.1 and 2.5.3

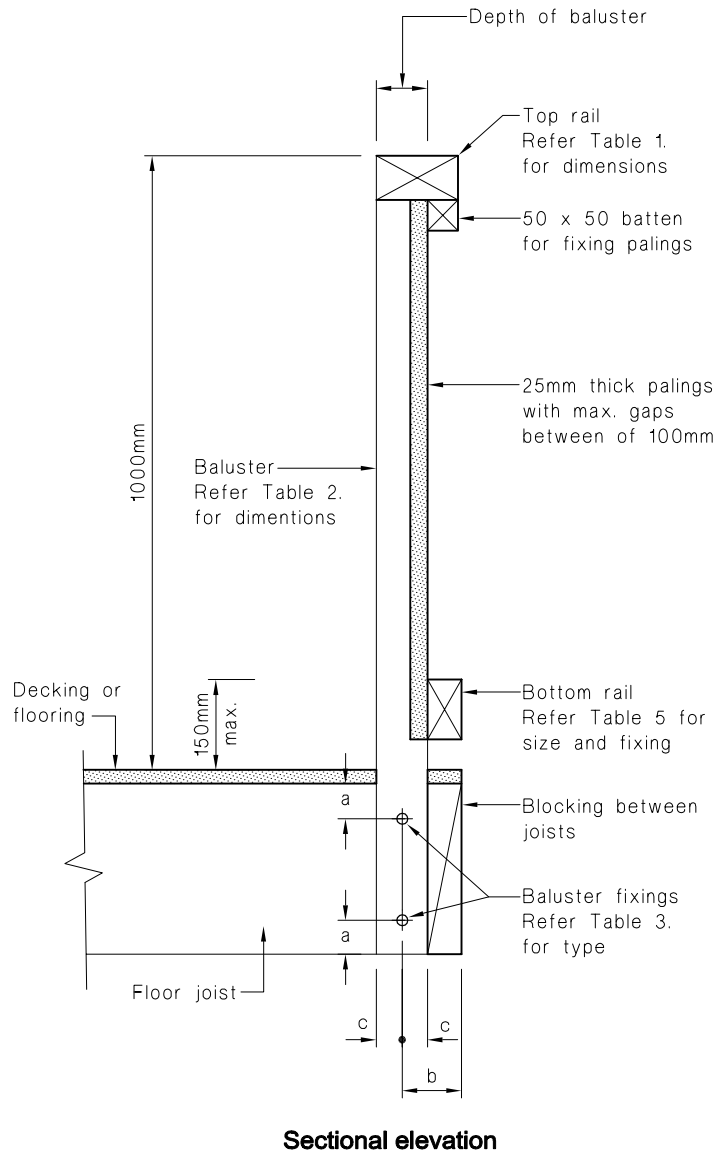

Amend 2  
Aug 1994

NOTE:  
See Table 4 for edge and end distances a, b and c.

Amend 2  
Aug 1994



**Figure 4: Baluster Fixed to Boundary Joist or End Joist**  
Paragraphs 2.3.2, 2.3.4, 2.3.5, 2.3.6, and 2.4.1

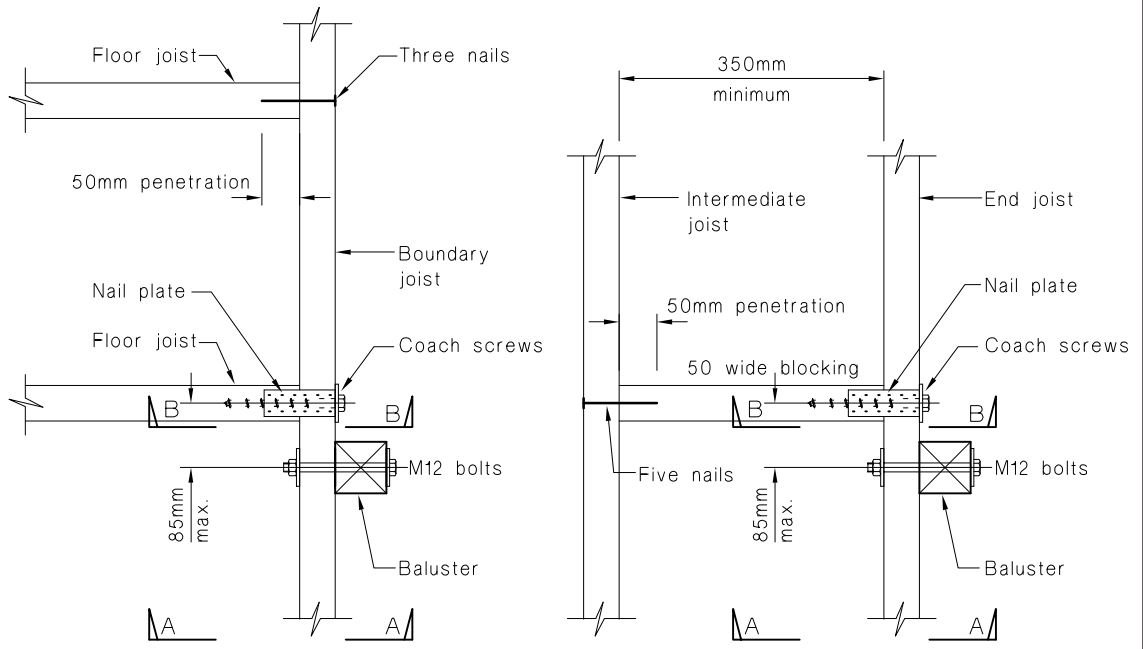

Amend 2  
Aug 1994

Amends 1  
and 2

Amend 2  
Aug 1994

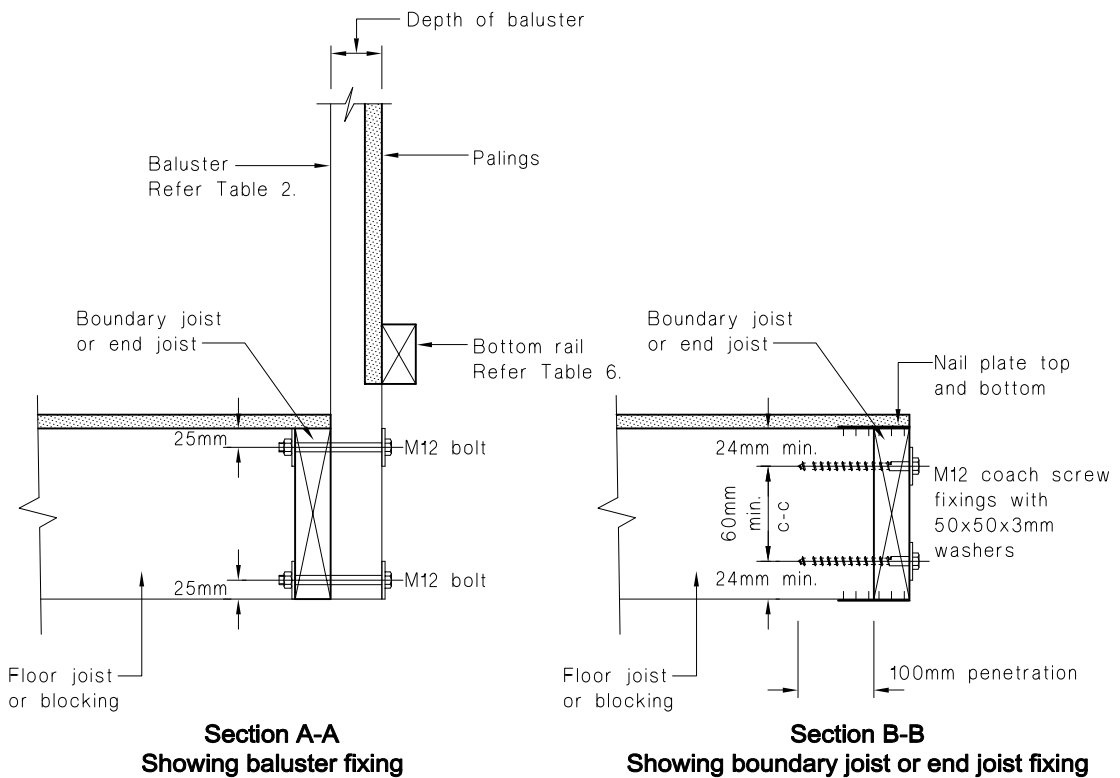

Amend 1  
Sep 1993

Amend 2  
Aug 1994

NOTE:  
Circular toothed plate connectors (CTP) are not required.

**Table 3: Bolted Connection of Baluster to Intermediate Joist**  
Paragraph 2.3.3 and Figure 3

Baluster spacing (c-c) (mm)	Type of bolted connection						
	Joist size (mm)						
	125 x 50	150 x 50	200 x 50	225 x 50	250 x 50	300 x 50	350 x 50
400	B	A	A	A	A	A	A
450	B	A	A	A	A	A	A
600		B	B	A	A	A	A
800			B	B	A	A	A
900			B	B	B	A	A
1000			B	B	B	A	A
1200				C	B	B	B
1350					B	B	B
1400					C	B	B
1500					C	B	B
1600						C	B
1700						C	B
1800						C	C
2000							C

Connection types: A – Two M12 bolts  
B – Two M12 bolts with 50 mm double sided circular toothed plate connectors  
C – Two M12 bolts with 63 mm double sided circular toothed plate connectors

Note:  
All bolts shall have 50 x 50 x 3 mm washers each end.

**COMMENT:**

- The nail plates may be of any type provided the above requirements are met. Acceptable types include plates with hammer-down claws or plates with pre-drilled holes for subsequent nailing.
- The coach screws may be replaced with any fixing(s) of equal durability and capable of carrying a shear load of 4 kN (capacity load as defined in NZS 3604).

**2.3.6** The end joist blocking required in Paragraph 2.3.4 shall be fixed with two 12 mm diameter coach screws, and with two nail plates (one at the top and one at the bottom) as shown in Figure 4. Coach screws shall have a minimum penetration of 100 mm and shall have a 50 x 50 x 3 mm washer. Nail plates shall comply with Paragraph 1.0.5 c) and shall be capable of carrying a tension force of 4.0 kN (capacity load defined in NZS 3604).

**COMMENT:**

- The nail plates may be of any type provided the above requirements are met. Acceptable types include plates with hammer-down claws or plates with pre-drilled holes for subsequent nailing.
- The coach screws may be replaced with any fixing(s) of equal durability and capable of carrying a shear load of 4 kN (capacity load as defined in NZS 3604).

**2.3.7** End and edge distances for bolts and for bolts with circular toothed plate connectors are given in Table 4.

Amend 1  
Sep 1993

Amend 2  
Aug 1994

Amend 2  
Aug 1994

Amend 1  
Sep 1993

Amend 1  
Sep 1993

Amend 2  
Aug 1994

Amend 2  
Aug 1994

**Table 4: Edge and End Distances for Bolts**  
Paragraph 2.3.7 and Figure 3

Fixing	Dimension as shown in Figure 3		
	a (mm)	b (mm)	c (mm)
M12 bolt	25	96	48
M12 bolt with 50 mm C.T.P.	31	89	32
M12 bolt with 63 mm C.T.P.	36	95	37

Note:  
C.T.P. – double sided circular toothed plate connector.

Amend 2  
Aug 1994

**2.3.8** Coach screws shall be fixed in predrilled holes located centrally in the width of the floor joist or blocking. The diameter of the predrilled holes shall be:

- a) Over the shank length, no less than the shank diameter and no more than the shank diameter plus 1.5 mm, and
- b) Over the threaded length, no more than the root diameter of the screw.

**2.3.9** The depth of the hole drilled to the diameter for the threaded length shall be at least two diameters greater than the intended depth of the screw. Coach screws shall not be hammered into place but shall be turned with a wrench.

Amend 1  
Sep 1993

**Table 5: Bottom Rail Sizes and Fixings to Baluster**  
Paragraph 2.4.1 and Figure 3

Baluster spacing (c-c) (mm)	Bottom rail	
	Size (mm)	Nail fixing (No)
Up to 1600	75 x 50	2
Up to 1700	100 x 50	2
Up to 1800	150 x 50	3
Up to 2000	100 x 75	3

Note:  
All nails shall be 3.75 mm shank diameter and penetrate no less than 50 mm into the *baluster*.

Amend 2  
Aug 1994

**2.4 Bottom rails**

**2.4.1** Bottom rails (see Figures 3 and 4) shall span between *balusters* and be sized and fixed in accordance with Table 5.

Amend 2  
Aug 1994

**2.5 Palings**

**2.5.1** Palings shall comprise 25 mm thick timber spanning between the top and bottom rails. Palings shall have a minimum width of 65 mm and be installed with a gap between palings of no more than 100 mm.

**COMMENT:**

Lightweight infills other than timber palings may be acceptable. The infill would require specific design.

**2.5.2** Palings shall be fixed to the top and bottom rails with:

- a) Two 60 mm x 2.8 mm shank diameter nails if the paling is 200 mm wide or less.
- b) 60 mm x 2.8 mm shank diameter nails at 150 mm centres if the palings are wider than 200 mm.

**2.5.3** With a Type 1 top rail the palings shall be fixed to the top rail using a 50 mm x 50 mm batten as shown in Figure 3. The batten shall be fixed to the top rail with 75 mm x 3.15 mm shank diameter nails at 300 mm centres.

**2.6 Timber moisture content**

**2.6.1** Timber in *balusters* and elements to which they are connected should be installed at similar moisture contents. The moisture content shall not exceed 20%.

## 2.7 Alternative details

**2.7.1** Where Figures in this acceptable solution show rails and top battens fixed to the outer face of *balusters*, it is also acceptable for them to be fixed to the inner face. It is also acceptable for the bottom rail and top batten to be cut between *balusters*.

**2.7.2** Palings may be nailed to either side of the rails and top battens.

# Verification Method B1/VM3 Small Chimneys

No specific test methods have been adopted for verifying compliance of small chimneys with NZBC Performance B1.



# Acceptable Solution B1/AS3

## Small Chimneys

### Scope

This acceptable solution applies to small *chimneys* and to supporting *hearth* slabs for solid fuel burning domestic appliances. It is to be read in conjunction with the Approved Document for NZBC C1 which has additional requirements to prevent outbreak of *fire*.

### 1.0 Chimney Construction

#### 1.1 General

##### 1.1.1 Type

The acceptable solutions described in this document are for *chimneys* built of brickwork, concrete or precast pumice concrete, that are connected to timber frame or masonry *buildings* complying with NZS 3604 or NZS 4229.

##### 1.1.2 Height

The height of any *chimney* measured from the top of the *chimney* foundation slab to the top of the *chimney* stack shall not exceed 9 m. *Chimneys* shall not cantilever more than 2.4 m above the fixing at roof level (refer Paragraph 1.7).

##### 1.1.3 Size

The width (measured along the *building* line) and depth (measured perpendicular to the *building* line) shall not exceed:

- a) For the foundation and *chimney* base
  - precast pumice concrete           1600 mm wide x 1050 mm deep
  - brickwork or concrete     1200 mm wide x 1050 mm deep
- b) For a brick *chimney* stack
  - single skin (see Figure 2)    500 mm wide x 500 mm deep
  - double skin (see Figure 3)   1200 mm wide x 680 mm deep
- c) For a concrete or precast pumice concrete *chimney* stack
  - 1200 mm wide x 700 mm deep

#### 1.1.4 Chimney liners

Where *chimney* liners are used they are to be separated from the *chimney* to ensure free thermal movement. This shall be achieved by coating the liner with a suitable debonding agent or by wrapping it in a *combustible* material no less than 0.25 mm thick.

#### 1.2 Chimney wall thickness

1.2.1 *Chimney* wall thicknesses shall be no less than:

- a) Brick
  - single skin (see Figure 2)   155 mm
  - double skin (see Figure 3)   245 mm
- b) Concrete                                 170 mm
- c) Precast pumice concrete               85 mm

These thicknesses apply to the *chimney* stack, *gather* and *chimney* base.

#### 1.3 Foundations

1.3.1 *Chimneys* shall be built on a foundation comprising walls and slab for suspended floors (see Figure 1(a)), or on a thickened slab for floor slabs on ground (see Figure 1(b)).

1.3.2 The *chimney* foundation slab shall be constructed in reinforced concrete, founded on *good ground*, and have:

- a) A thickness of no less than 200 mm, and be placed at a depth of no less than 300 mm below surrounding ground level.
- b) Reinforcement as shown in Figure 1.
- c) D12 starters at 400 mm maximum centres, to match vertical steel locations in the *chimney*.

1.3.3 The *chimney* foundation walls shall be 150 mm thick reinforced concrete, 190 mm thick concrete masonry, or brick *construction* complying with Figures 2 or 3. Vertical and horizontal reinforcing steel shall be as given in Paragraph 1.6.

**Figure 1: Chimney Foundation**  
Paragraphs 1.3.1, 1.3.2 b) and 1.4.1, and Figures 2, 3, 4 and 5

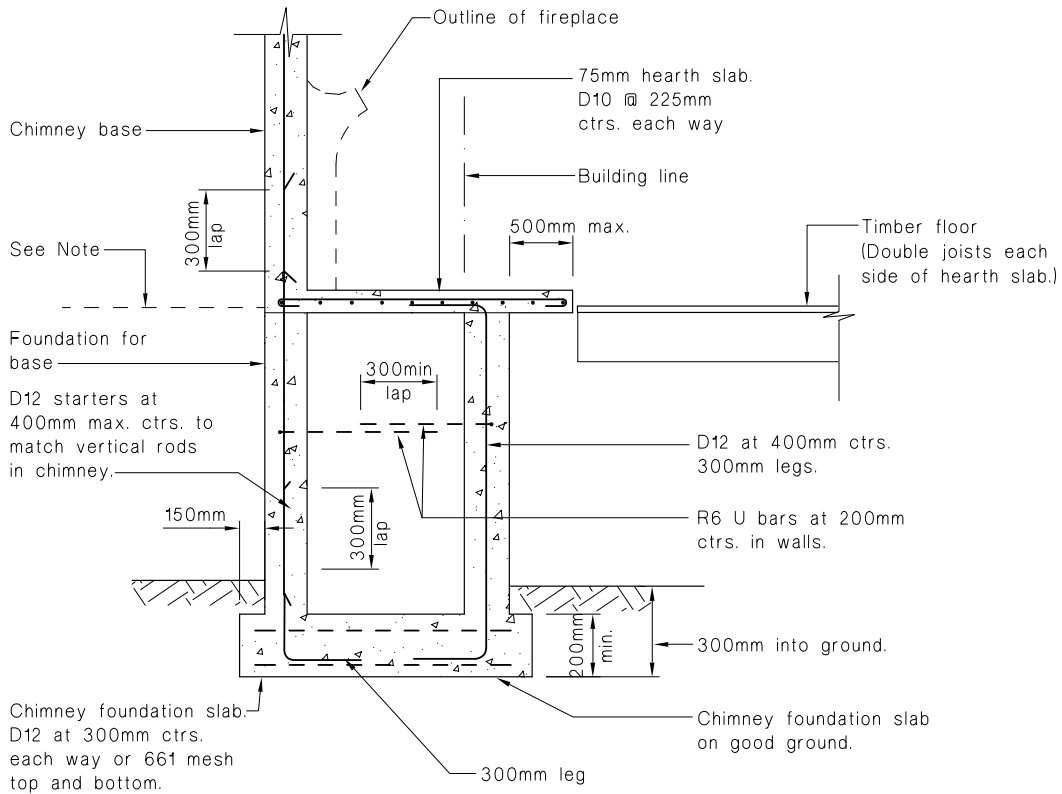

**(a) Suspended floor**

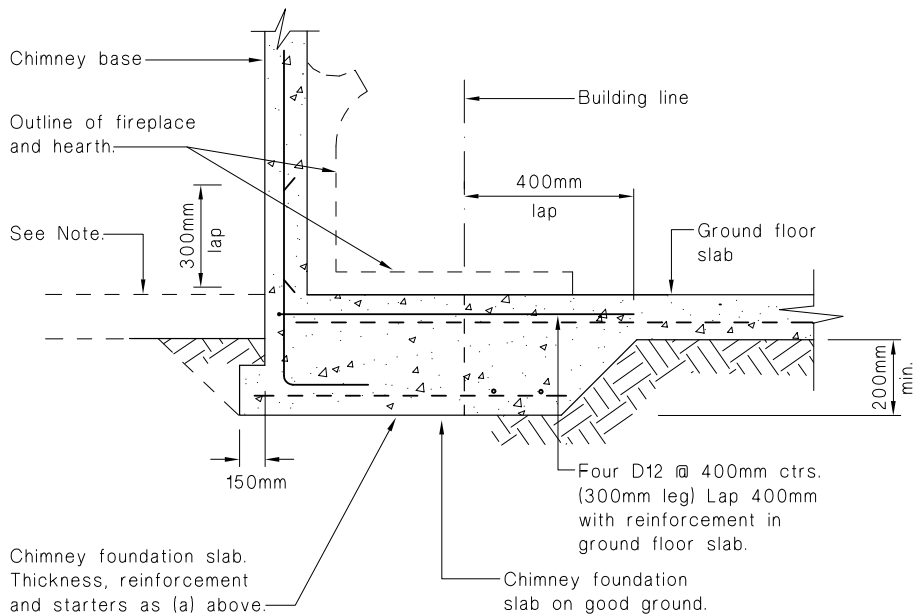

**(b) Slab on ground**

NOTE:  
Figures 1(a) and 1(b) have been drawn for the chimney being exterior to the building. The dotted line indicates the timber floor in Figure 1(a) and the ground floor slab in Figure 1(b) for the situation where the chimney is internal.



**Figure 2: Brick Chimney with Liner**  
Paragraphs 1.1.3 b), 1.2.1 a), 1.3.3, 1.6.1, 1.7.2, 1.7.5 and 1.7.6

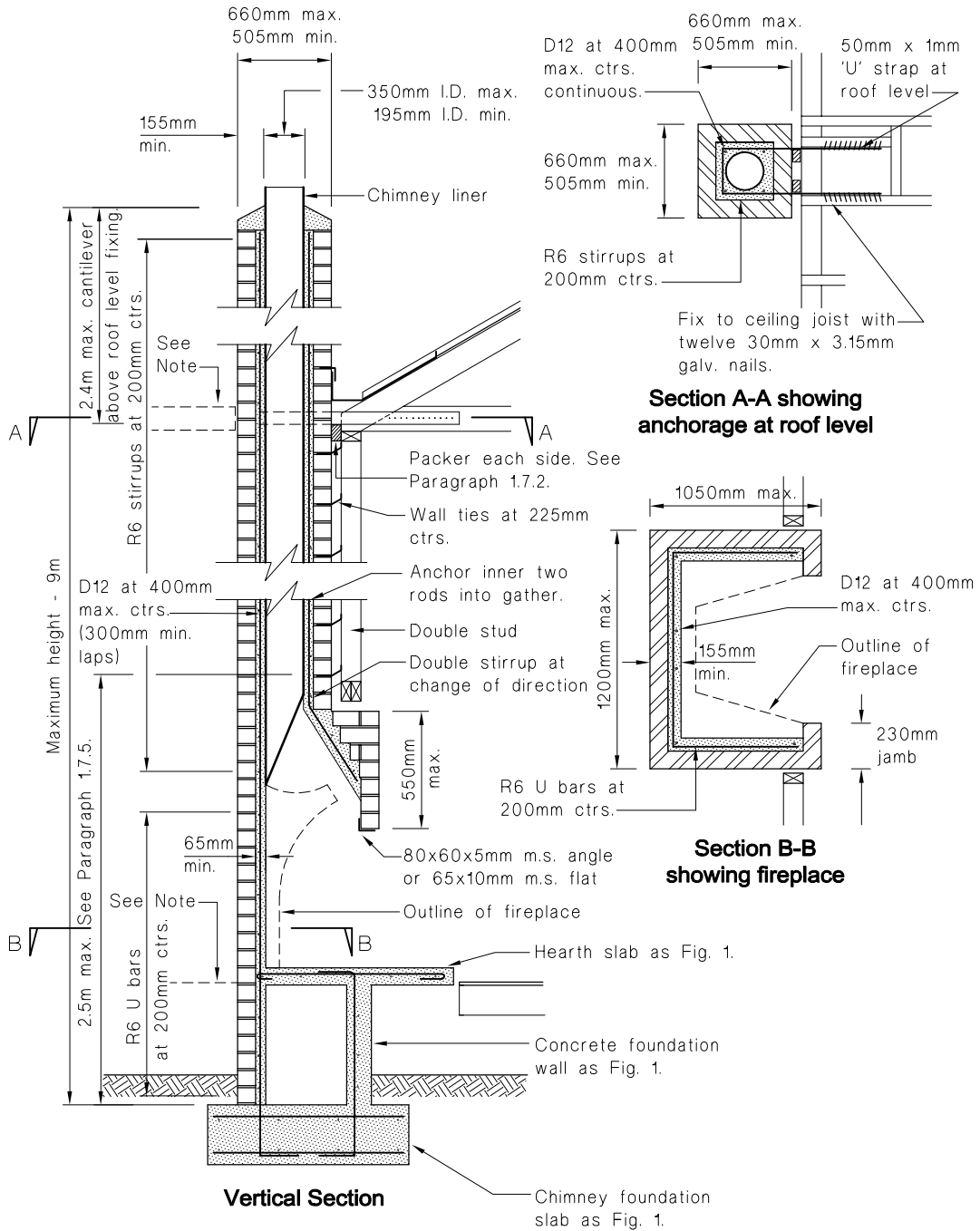

**NOTES:**

Figure 2 has been drawn for the chimney being exterior to the building. The dotted lines indicate the ceiling joists and floor for the situation where the chimney is internal.

Flues must be sized to ensure adequate draught. Sizing depends on many factors including the height of the flue but generally flue cross sectional area needs to be a minimum of 1/12th of the fireplace opening. The flue also needs to be sufficiently large to enable cleaning. 195mm is regarded as a practical minimum diameter.

Amend 2  
Aug 1994

Amend 2  
Aug 1994

**Figure 3: Brick Chimney Without Liner**  
Paragraphs 1.1.3 b), 1.2.1 a), 1.3.3, 1.6.1, 1.7.2, 1.7.5 and 1.7.6

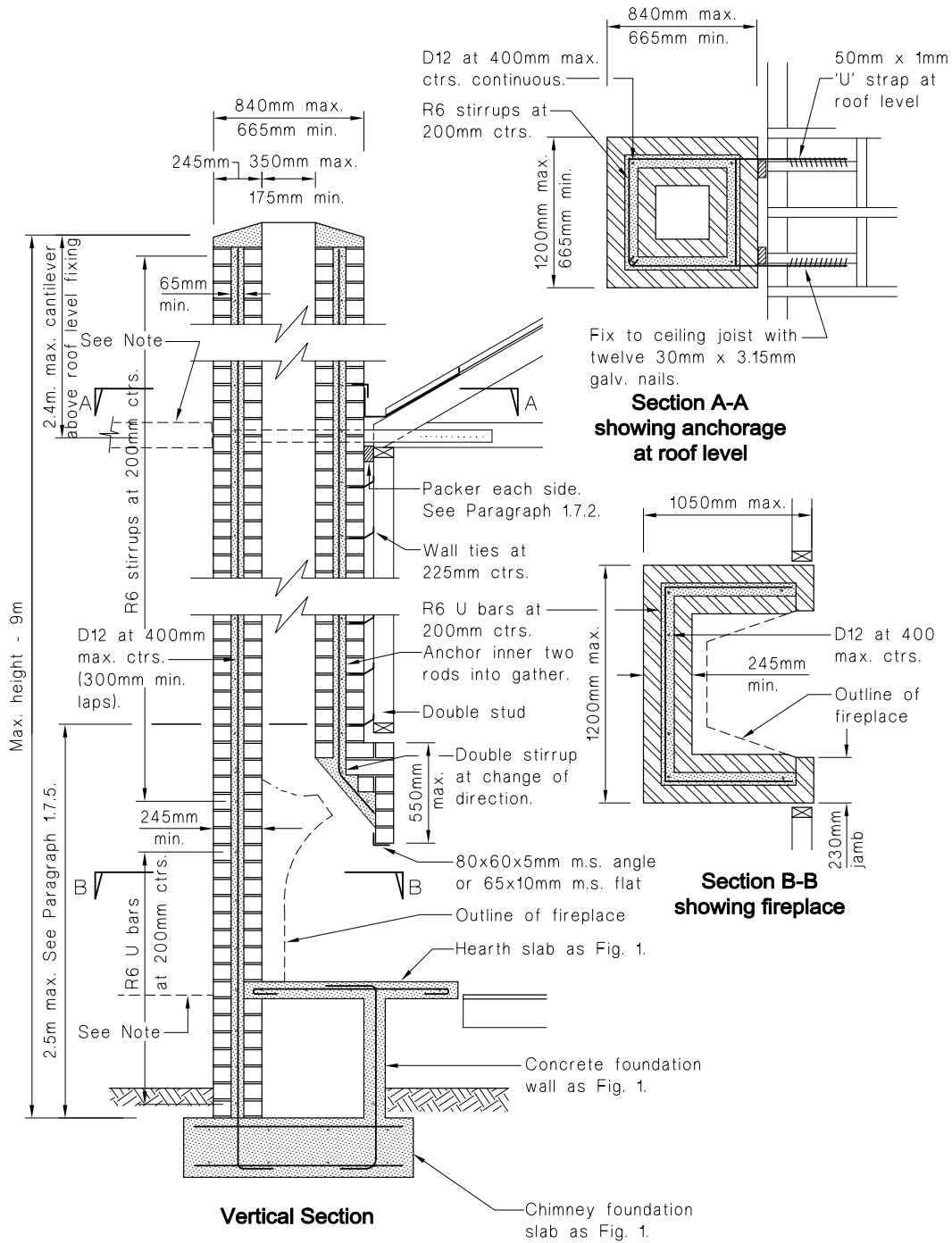

NOTES:

- Figure 3 has been drawn for the chimney being exterior to the building. The dotted lines indicate the ceiling joists and floor for the situation where the chimney is internal.
- Flues must be sized to ensure adequate draught. Sizing depends on many factors including the height of the flue but generally flue cross sectional area needs to be a minimum of 1/12th of the fireplace opening. The flue also needs to be sufficiently large to enable cleaning. 175 x 175 mm is regarded as a practical minimum size.

Amend 2  
Aug 1994

Amend 2  
Aug 1994

**1.4 Hearths**

**1.4.1** *Hearth* slabs shall be of concrete no less than 75 mm thick, reinforced with D10 bars located centrally at 225 mm centres each way. See Figure 1.

**1.5 Chimney breasts**

**1.5.1** The widths of openings in *chimney breasts*, and their supporting lintels, shall comply with Table 1.

Table 1: Chimney Breast Openings and Lintels Paragraph 1.5.1 and Figure 4	
Opening width	Lintel reinforcing
<b>Brick</b> 1.0 m maximum	65 x 10 mm m.s. flat or 80 x 60 x 5 mm m.s. angle
<b>Concrete</b> Up to 900 mm 900 – 1500 mm	Two D10 rods D12 upper rod D16 lower rod
<b>Precast pumice</b> 1.0 m maximum	Two D10 rods
<p>Note: Horizontal reinforcing rods to concrete and precast pumice are to be placed one above the other at a spacing of 75 mm, and have R6 ties at 150 mm maximum centres.</p>	

**1.6 Reinforcing**

**1.6.1** Reinforcing of foundation walls, *chimney bases* (including the *gathers*) and *chimney* stacks (see Figures 2 to 5 inclusive) shall comprise:

- a) D12 bars at 400 mm maximum centres vertically. Laps in bars shall be no less than 300 mm.
- b) R6 bars at 200 mm centres horizontally. These will be in the form of closed stirrups in the stack and U bars elsewhere.
- c) Double horizontal reinforcing at any change in direction of the vertical steel (e.g. at the *gather/stack* intersection).

**1.6.2** Bars which do not extend for the full height of the *chimney* shall be stopped in the *gather*:

- a) In reinforced concrete and brick, by continuing these bars through to the far face of the *gather* and terminating with a 200 mm leg.
- b) In precast pumice concrete, by anchoring the last 200 mm of the bar in a high strength cementitious grout. (See Figure 5.) Refer Paragraph 1.8.3 g) for grout details.

**1.7 Chimney restraint**

**1.7.1** *Chimneys* which are not constructed integrally with the *building* shall be secured by floor and roof brackets. An acceptable alternative for brick and precast pumice concrete *chimneys* is that they be restrained by a roof tie used in conjunction with closely spaced wall ties. (Refer Paragraphs 1.7.5 to 1.7.16.)

**1.7.2** Where a packer (see Figures 2, 3, 6 and 7(b)) is shown between the *chimney* and *building* it shall be:

- a) Concrete, brick, steel (angle, channel or Z section), or any insulating material which has a long term operating temperature of no less than 150°C,
- b) Secured in place to prevent it dislodging, and
- c) Capable of withstanding a compressive force of 10 kN without shortening by more than 1.5 mm.

**COMMENT:**

C/AS1 Part 9 requires a 50 mm separation between the *chimney* and any *combustible* material. Where the *chimney* fixing described does not prevent the *chimney* moving within this gap, a packer is shown.

Amend 5  
Jul 2001

**1.7.3 Floor and roof brackets**

The brackets shall comprise a 50 mm x 4 mm hot dip galvanised steel strap placed around the *chimney*. Each leg of the strap shall be horizontal and shall be bolted to the joists with three M12 bolts at 75 mm centres as shown in Figure 6.

**Figure 4: Reinforcing Details – Concrete and Brick Chimneys**  
Paragraph 1.6.1

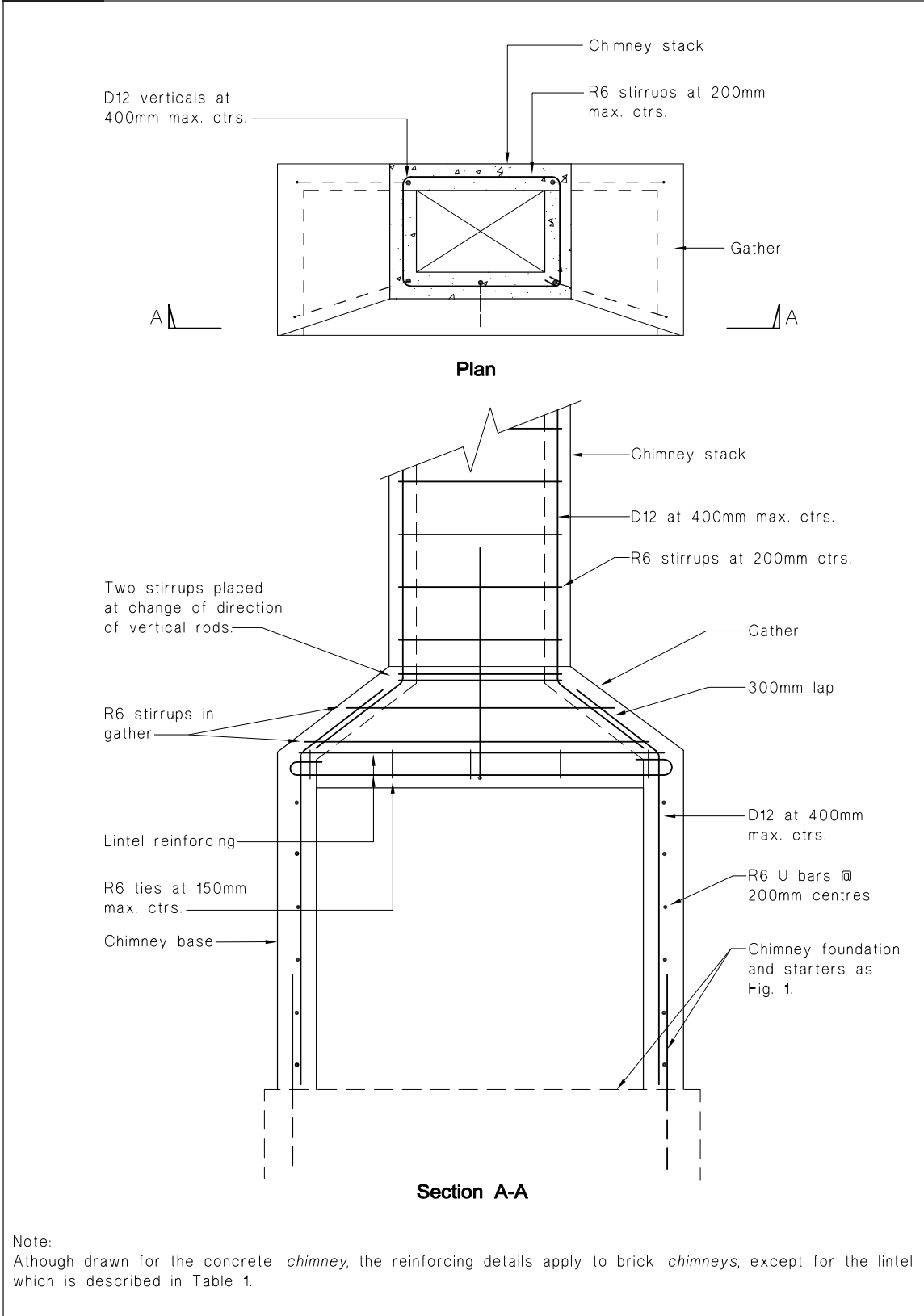

**Figure 5: Reinforcing Details – Precast Pumice Concrete Chimney**  
Paragraphs 1.6.1 and 1.6.2 b)

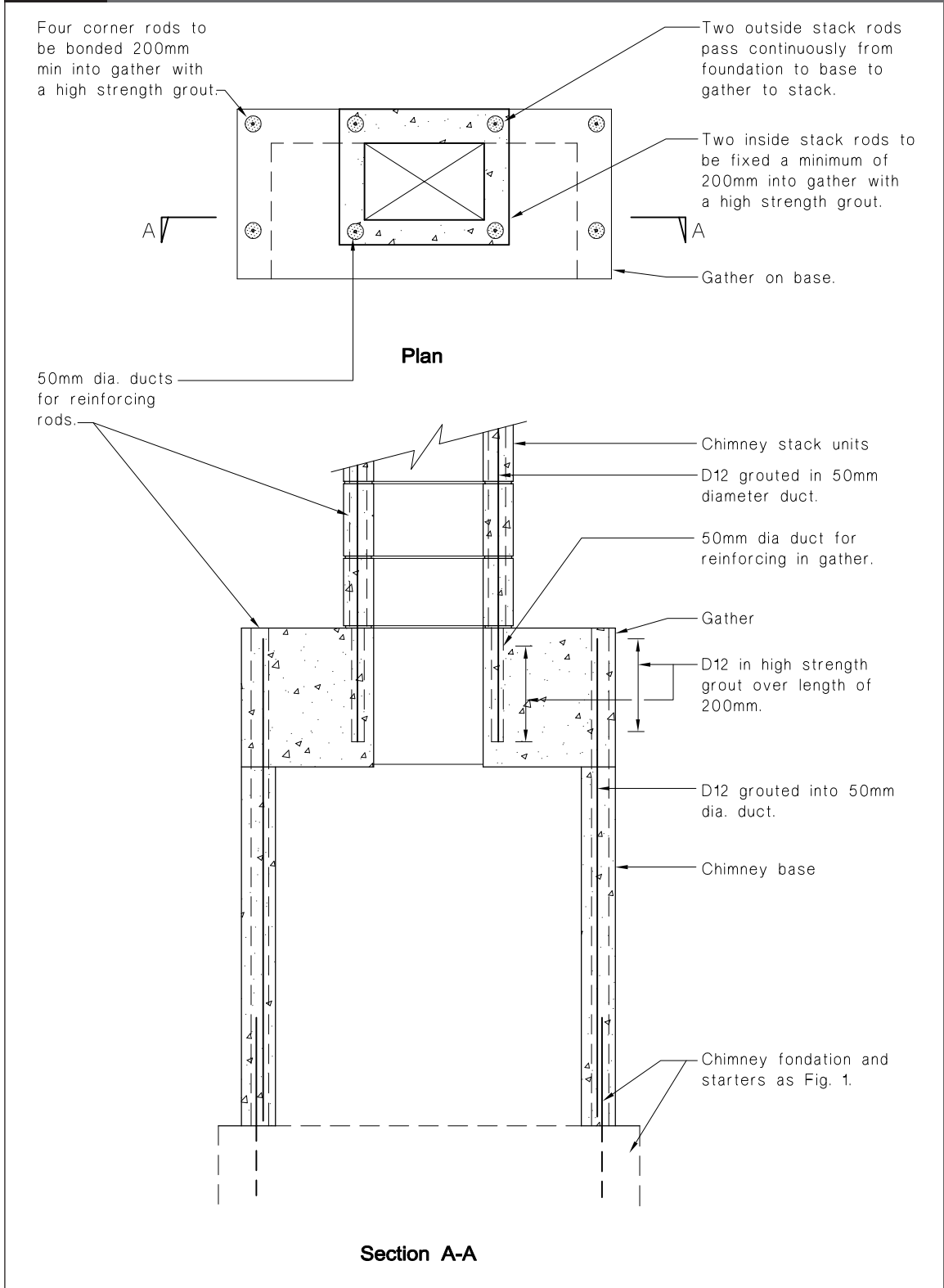

**1.7.4** Brackets shall be located so that the distance between the top of the *chimney* foundation slab and the first bracket, and the distance between adjacent brackets does not exceed 3.0 m. Where a *chimney* foundation wall is integral with a *building* foundation wall, then the height to the first bracket may be measured from the top of the *building* foundation wall.

**1.7.5 Alternative fixing using roof tie and closely spaced wall ties**

This alternative *chimney* fixing shall apply only from the *gather* to roof level. It requires that either the top of the *chimney* foundation slab or a floor bracket complying with Paragraph 1.7.3 be located within a distance of 2.5 m below the first of the closely spaced wall ties. (See Figures 2 and 3.) If the latter applies, the *chimney* below this bracket shall be fixed by floor brackets spaced in accordance with Paragraph 1.7.4.

**1.7.6 Brick chimneys**

Brick *chimneys* shall be restrained at roof level by a zinc coated 50 x 1.0 mm mild steel 'U' strap used in conjunction with closely spaced wall ties. The strap shall be:

- a) Cast into the grout and wrap around the reinforcing steel (see Figures 2 and 3),
- b) Placed at no more than 20° from the horizontal,
- c) Used in conjunction with a packer (complying with Paragraph 1.7.2) placed at the same level, and
- d) Fixed with twelve 30 x 3.15 mm galvanised nails to roof or ceiling framing.

**1.7.7** Wall ties (see Figure 7(a)) shall be located in mortar joints at 225 mm maximum centres up each side of the *chimney*, except that pairs of ties shall be used for *chimneys* wider than 600 mm.

**1.7.8** Wall ties shall be constructed from either 4 mm diameter galvanised bar or 25 x 1.5 mm zinc coated steel strip capable of withstanding a load of 1.2 kN without elongating or shortening by more than 1.5 mm.

**1.7.9** Where zinc coating of components is required it shall be no less than 300 g/m<sup>2</sup> in accordance with AS 1397.

**1.7.10** Nails used to fix straps to roof or ceiling framing shall be spaced at no less than 35 mm in Radiata Pine, and 70 mm in other timbers.

**1.7.11** Acceptable alternatives to the cast-in 'U' strap are:

- a) Any proprietary bracing strip system of equal durability to the 'U' strap described in Paragraph 1.7.6, and capable of carrying a seismic force of 12 kN without elongating by more than 1.5 mm, or
- b) A cast-in hot dip galvanised, deformed 6.0 mm reinforcing bar bent to a 'U' shape, with each end fixed to the roof or ceiling framing with six 50 x 4.0 mm galvanised fencing staples.

**1.7.12** The 'U' strap or either of the acceptable alternatives may be wrapped around the outside of the *chimney* rather than be cast-in, provided that if strap is used it shall be painted with a zinc rich primer.

**1.7.13 Precast pumice concrete chimneys**

Precast pumice concrete *chimneys* shall be restrained at roof level either by a 50 x 1 mm 'U' strap wrapped around the *chimney*, or by a hot dip galvanised deformed 6 mm reinforcing bar placed into the grout around the reinforcing steel, together with either fixing brackets or fixing ties (see Figure 7(b)). Straps and bars shall satisfy the relevant requirements of Paragraphs 1.7.6 to 1.7.12.

**1.7.14** Fixing brackets (see Figure 7(b)) shall be made from 5.0 mm thick mild steel angle and drilled with:

- a) A 50 mm diameter hole to suit the reinforcing duct location, and
- b) A 14 mm diameter hole for the 12 mm diameter coach screw fixing to the double stud.

**1.7.15** Fixing brackets shall be located in mortar joints between the units, and be spaced at no less than 480 mm centres for stacks up to 600 mm wide, and no less than 320 mm centres for stacks wider than 600 mm.

**Figure 6:** Chimney Restraint – Floor and Roof Brackets  
Drawn for Roof Restraint  
Paragraphs 1.7.2 and 1.7.3

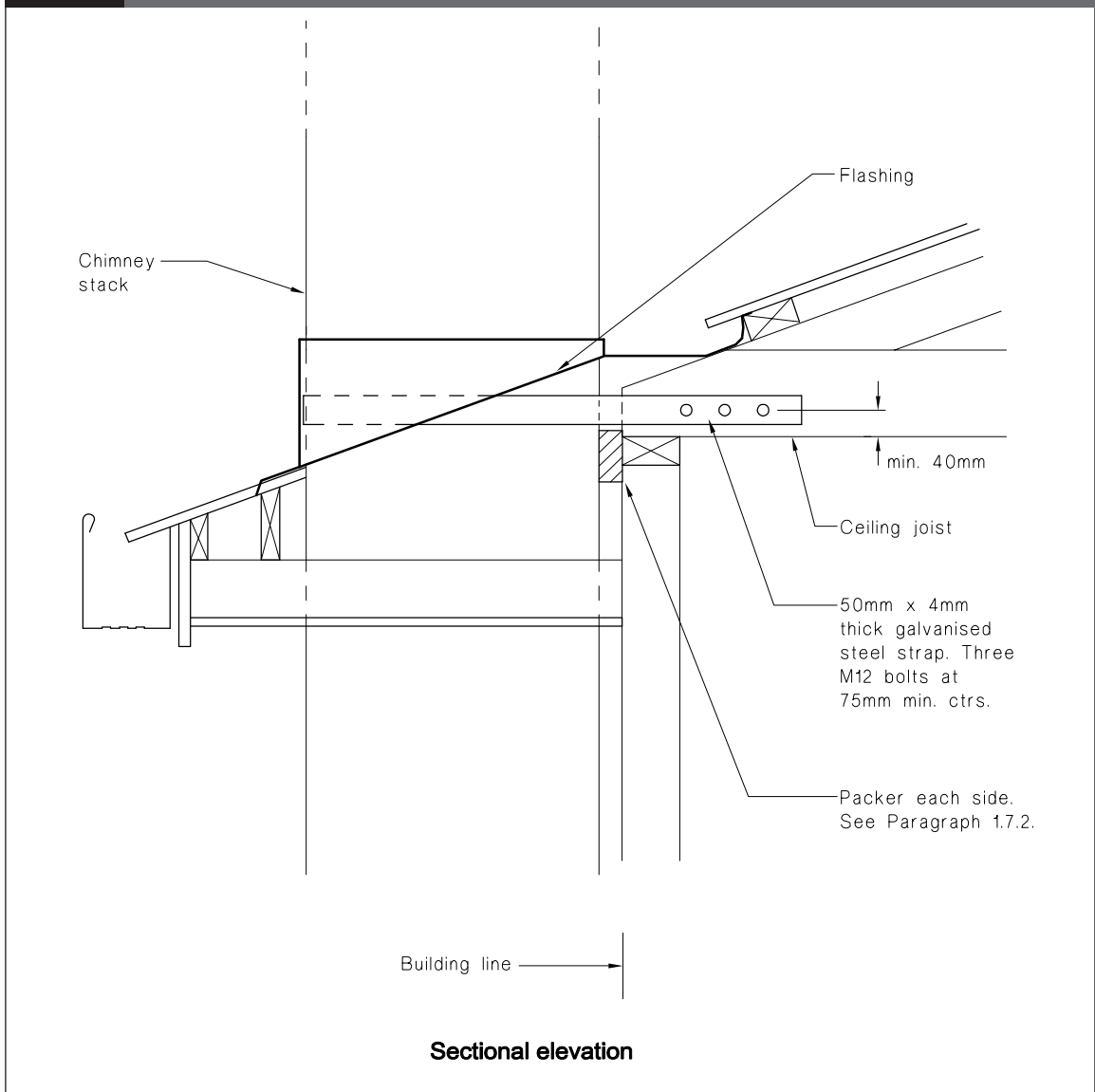

Note:  
Although drawn for a chimney on an exterior wall, the bracket details also apply to an interior chimney.

**Figure 7: Chimney Restraint**  
Paragraphs 1.7.2, 1.7.7, and 1.7.13

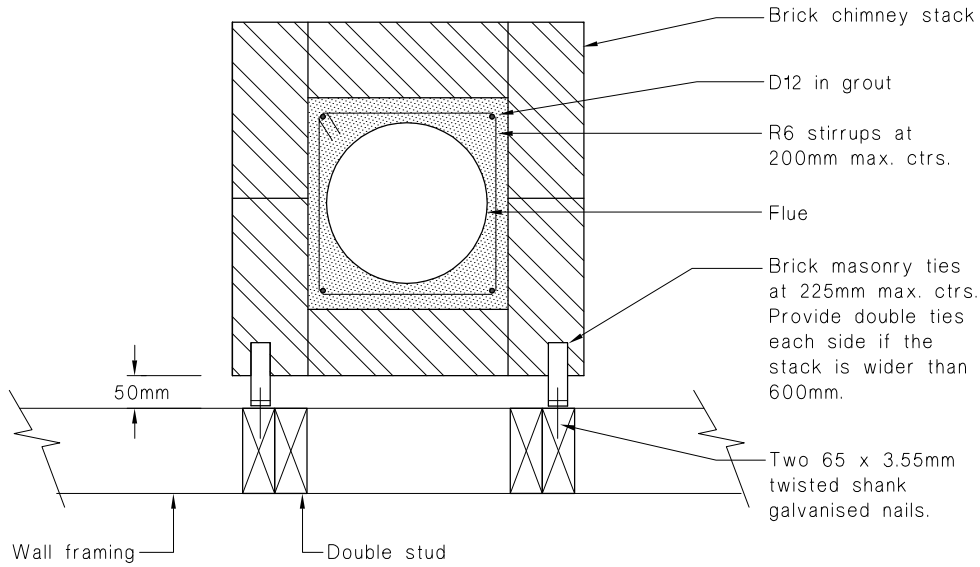

**(a) Brick chimney**

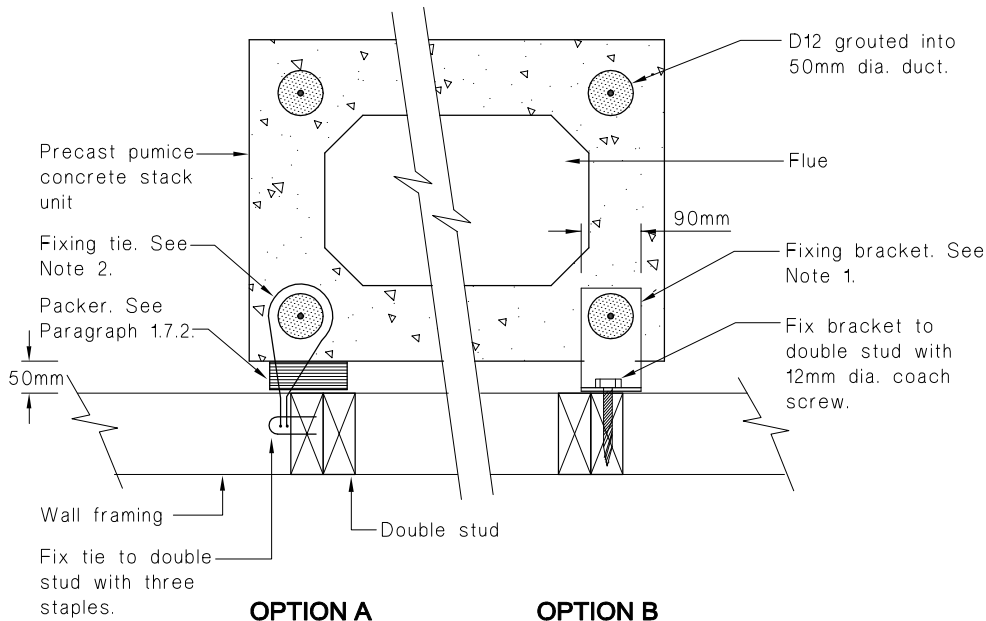

**OPTION A**

**OPTION B**

**(b) Precast pumice concrete chimney**

Notes:

1. Brackets shall be made from 5 mm thick m.s. angle drilled with 50 mm dia. hole to suit the reinforcing duct. Locate brackets in the mortar joints between units at no more than:
  - 480 mm maximum centres for stacks up to 600 mm wide
  - 320 mm maximum centres for stacks over 600 mm wide
2. Ties shall comprise 4 mm galvanised hairpins located in the mortar joint between units at no more than:
  - 320 mm maximum centres for stacks up to 600 mm wide
  - 160 mm maximum centres for stacks over 600 mm wide



**1.7.16** Fixing ties shall comprise 4 mm galvanised wire hairpins, which are hooked behind the reinforcing ducts and secured to the required adjacent double studding with four heavy duty fencing staples. The ties shall be located in mortar joints between the units and be at no less than 320 mm centres for stacks up to 600 mm wide, and no less than 160 mm centres for stacks wider than 600 mm.

## 1.8 Materials and construction

### 1.8.1 Brickwork

Brick *chimney* construction shall conform to the relevant sections of NZS 4210.

### 1.8.2 Concrete

*Chimneys*, foundations and *hearth* slabs of reinforced concrete, shall comply with the relevant clauses of NZS 3109 for ordinary grade concrete.

### 1.8.3 Precast pumice concrete

Pumice concrete units for use in precast *chimneys* shall:

- a) Have pumice aggregate which:
  - i) is free of *combustible* and organic matter, and
  - ii) has a maximum aggregate size of no greater than 19 mm, with at least 40% but not more than 60% of the aggregate retained by a 4.75 mm standard test sieve, and
- b) Have a mix ratio by volume of no more than five parts of mixed pumice aggregate to one part of cement,
- c) Have a compressive strength of no less than 7 MPa at 28 days when cured and tested in accordance with NZS 3112: Part 2,
- d) After adequate curing, be air dried and kept under cover during storage, transport and on the site,
- e) Be laid dry. (Work left unfinished should be protected from rain.)
- f) Be joined with mortar which complies with NZS 4210, and

- g) Have ducts filled with grout complying with NZS 4210, except over the last 200 mm where bars are anchored in the *gather* (refer Paragraph 1.6.2 b)). At these locations a non-shrinking cement-based grout, which attains a minimum compressive strength of 30 MPa at 7 days, shall be used.

### 1.8.4 Concrete masonry

Concrete masonry *construction* for *chimney* foundation walls shall conform to the relevant sections of NZS 4229.

### 1.8.5 Reinforcing steel

Reinforcing used in *chimneys* is to conform to AS/NZS 4671, and shall:

- a) For brick, be embedded centrally in the thickness of the grout,
- b) For in-situ concrete, have cover to the steel in accordance with NZS 3109,
- c) For precast pumice concrete, be placed with grout in the preformed ducts in the units.

### 1.8.6 Hot dip galvanising

Hot dip galvanising shall comply with AS/NZS 4680.

## 1.9 Systems to resist horizontal earthquake loadings

**1.9.1** The bracing described in Paragraphs 1.9.2 to 1.9.6 shall be provided in those *buildings* where one or more of the following apply:

- a) The area of the room containing the *chimney* exceeds 24 m<sup>2</sup>,
- b) The length of the wall on which the *chimney* is located exceeds 3.5 m between supporting braced walls which are perpendicular to it. This length may be increased to 6.5 m where the wall is supported, at each floor level and at the roof or ceiling level, by either a structural diaphragm which conforms with the relevant requirements of NZS 3604 or by dragon ties. The dragon ties shall:

Amend 9  
Sep 2010

Amend 9  
Sep 2010

Amend 5  
Jul 2001

- i) consist of a continuous length of 100 x 50 mm timber fixed in accordance with NZS 3604 clauses 8.3.3.3 and 8.3.3.4,
  - ii) be run as a pair, with one dragon tie going from the wall on which the *chimney* is located, back to each of the supporting braced walls. The enclosed angle between the wall on which the *chimney* is located and each dragon tie shall be 60°, and
  - iii) be located no more than 1.5 m out from each supporting braced wall.
- c) The floor area on any level of the *building*, for a given *chimney* type (see Table 2), is less than:
- i) 50 m<sup>2</sup> for *chimney* Type 1,
  - ii) 75 m<sup>2</sup> for *chimney* Types 2, 3 and 4,
  - iii) 150 m<sup>2</sup> for *chimney* Types 5, 6 and 7.

**1.9.2** The *building* supporting the *chimney* shall contain bracing elements to resist earthquake loads from the *chimney*. These loads are applied at roof level and at each floor to which the *chimney* is connected. The bracing elements necessary are additional to those required by NZS 3604 or NZS 4229.

**1.9.3** The number of bracing units to be provided for each *chimney* connection (see Paragraph 1.9.4) is given in Table 2. The number of bracing units to be provided at any level shall be the sum of the bracing units required at each of the *chimney* connections above the level being considered.

**COMMENT:**

As an example: for a standard precast pumice concrete *chimney* in a two storey *building* in Zone A, that is connected to the *building* by a roof bracket and by floor brackets at ground and first floor, the number of bracing units required are:

Location	Bracing units required
– Just below roof level	60
– Just below first floor level	60 + (60% of 60) = 96
– Just below ground floor level	60 + (60% of 60) + 60 = 156

**1.9.4** A *chimney* shall be considered as connected to the *building* when:

- a) At roof level: it is held either by a roof bracket or by a roof tie,
- b) At ground floor level: it is held by a floor bracket or the *chimney base* is integral with the *building* foundation wall,

**Table 2: Bracing Units Required for Each Chimney Connection to Resist Earthquake Loadings**  
Paragraphs 1.9.1c) and 1.9.3

Chimney construction	Type	Max size of chimney:		Number of bracing units required at the roof connection and at each floor connection according to earthquake zone: (See Note 1)				
				Stack	Base	Zone A	Zone B	Zone C
Precast pumice								
– standard	1	500 x 400	1600 x 1050	60	50	40		
– large	2	1100 x 400	1600 x 1050	110	90	70		
Brick								
– single skin	3	500 x 500	1200 x 1050	90	70	60		
– double skin	4	590 x 590	1200 x 1050	130	100	80		
	5	1200 x 680	1200 x 1050	240	200	160		
Concrete	6	590 x 590	1200 x 1050	210	170	140		
	7	1200 x 700	1200 x 1050	390	320	260		

**Note:**

- The number of bracing units required at floor connections other than the ground floor shall be taken as 60% of the value given in the table.

c) At an intermediate floor level: it is held either by a floor bracket or by closely spaced wall ties spanning the floor.

**1.9.5** For earthquake ground movement in the direction perpendicular to the wall on which the *chimney* is located, structural diaphragms shall be provided at roof/ceiling level and at each floor level to which the *chimney* is connected. The diaphragms shall comply with all relevant clauses of NZS 3604 and NZS 4229.

**1.9.6** For earthquake in the direction parallel to the wall on which the *chimney* is located, the bracing units required as determined from Paragraph 1.9.3 shall be provided solely by that wall.

## 2.0 Solid Fuel Burning Domestic Appliances

### 2.1 Chimneys

**2.1.1** *Chimneys* for solid fuel burning appliances shall comply with Paragraph 1.0 or with the relevant sections of AS/NZS 3869 and AS/NZS 2918 for sheetmetal *chimneys*.

Amend 9  
Sep 2010

### 2.2 Hearth slab

**2.2.1** Solid fuel burning domestic appliances weighing no more than 130 kg shall be supported on a 65 mm thick *hearth* slab that is:

- a) Reinforced with 665 mesh, or D10 rods at 300 mm centres each way, placed centrally in the slab thickness,
- b) Supported on a timber or concrete floor, or integral with a concrete floor. (The floor supporting the *hearth* slab shall comply with NZS 3604 or NZS 4229 as appropriate), and
- c) Comprised of ordinary grade concrete complying with the relevant clauses of NZS 3109.

**2.2.2** *Hearth* slabs on a timber floor shall be held in position by supporting members on all four sides of the *hearth*. These members shall each be held by four screws with a minimum shank diameter of 4.88 mm that penetrate the floor framing by 50 mm.

**2.2.3** *Hearth* slabs on concrete floors shall be secured in position by four D10 starter rods. The rods shall be located in each corner of the *hearth* slab and they shall terminate each end with standard hooks complying with NZS 3109.

### Spread of fire

**2.2.4** Paragraphs 2.2.1 to 2.2.3 provide an acceptable structural solution, but depending on the particular installation, different *hearth* dimensions may be necessary to meet the spread of *fire* requirements of NZBC Clause C1.3.2. *Hearth* slabs for solid fuel burning appliances shall comply with AS/NZS 2918.

Amend 2  
Aug 1994

Amend 9  
Sep 2010  
Amend 5  
Jul 2001



# Verification Method B1/VM4 Foundations

(Revised by Amendment 4)

## 1.0 Scope and Limitations

**1.0.1** This document covers the ultimate limit state design of foundations, including those of earth retaining structures. Methods are given for determining ultimate bearing and lateral sliding strengths.

**1.0.2** This document does not describe a means of determining the value of the soil parameters used in the document (e.g.  $c^l$ ,  $\phi^l$  and  $s_u$ ). The derivation of these parameters, which must be based on the most adverse moisture and groundwater conditions likely to occur, is outside of the scope of this verification method.

**COMMENT:**

Appendix A contains information on the types of investigations that may need to be conducted to determine the soil parameters.

**1.0.3** Serviceability limit state deformations are not covered in this document. The determination of such deformations and their acceptability to the design in question needs to be considered but is outside the scope of this document.

**COMMENT:**

Appendix B contains information which may be of assistance in designing for serviceability limit state deformations.

It is intended that design provisions to cover serviceability limit state deformations be added to the document in the future.

**1.0.4** This document assumes general ground or slope stability and provides methods only for ensuring against local failure of the foundation. Overall ground stability needs to be verified before this document can be applied; this is outside the scope of this verification method.

**1.0.5** This document must not be used to design foundations on loose sands, saturated dense sands or on cohesive soils having a sensitivity greater than 4.

**COMMENT:**

Saturated sands may be subject to liquefaction during earthquake loading and sensitive clays exhibit a rapid decrease in undrained shear strength once the peak strength has been mobilised. The design of foundations on these materials needs special considerations which are not covered in this verification method.

**1.0.6** This document shall not be used for foundations subject to continuous vibration.

**COMMENT:**

Although this document covers foundations subject to vibration from earthquake loading it does not cover those applications where foundations are subject to continuous vibration such as from the operation of certain machinery.

**1.0.7** The "Comments" and "Informative Appendices" of this document provide comment, background or general information but do not form part of this verification method.

**COMMENT:**

Appendix C contains a worked example showing how some of the provisions of this document are used.

## 2.0 General

**2.0.1** Foundations must be designed for the load combinations given in AS/NZS 1170 Part 0, as amended by B1/VM1. *Strength reduction factors* given in this document must be used to determine the design strength of the foundation. The design loadings must not cause the foundation's design strength to be exceeded.

**2.0.2** The design procedures of this document must be performed by a person who, on the basis of experience or qualifications, is competent to apply them.

**2.0.3** The *building's* foundation elements or the elements of earth retaining structures shall be designed in accordance with the appropriate material Standards, as given in B1/VM1.

**2.0.4** Foundations may be shallow or deep. A shallow foundation is one in which the

Amend 8  
Dec 2008

Amend 8  
Dec 2008

depth from the ground surface to the underside of the foundation is less than five times the width of the foundation. All other foundations are considered to be deep.

**2.0.5** In assigning values for soil parameters the worst groundwater condition shall be considered.

**COMMENT:**

For cohesive soils the fully saturated condition will generally give the lowest strength and stiffness.

**2.0.6** Foundation strength for cohesive soil depends on loading duration and whether consolidation can occur. For this reason the distinction is made between short term (e.g. initial load application, earthquake actions or wind gusts) and long term loading (e.g. permanent loads such as foundation dead load). For the short term case no consolidation occurs and the calculations shall be in terms of undrained shear strength (i.e. shear strength of the soil  $s_u$ ) and total stress. For long term loading, full consolidation occurs and the calculations shall be in terms of drained shear strength and effective stress (i.e. soil parameters being cohesion,  $c^l$ , and the angle of shearing resistance  $\phi^l$ ).

**2.0.7** For cohesionless soils consolidation occurs very quickly so drained strength shall be used in all cases.

**2.0.8 Supervision and verification of soil parameters**

Design assumptions and soil parameters shall be verified during *construction*. The designer shall nominate what supervision, including verification of soil parameters, will be undertaken during the *construction* period.

**3.0 Shallow Foundations**

**3.1 General Provisions**

**3.1.1** The ultimate bearing strength shall be based on the most adverse moisture and groundwater conditions likely to occur.

**3.1.2** Founding depths in clay soils known to exhibit swelling and shrinking behaviour shall be chosen so that the underside of the

foundation is beneath the zone of soil affected by shrinking and swelling caused by seasonal weather changes, and the root systems of nearby trees and shrubs.

**3.1.3** Consideration shall be given to the possibility of any surcharge adjacent to a shallow foundation being removed during the life of the foundation, so reducing the available ultimate bearing strength.

**3.1.4** Foundations subject to moment loading shall not be proportioned such that the point of application of the reaction force on the underside of the foundation is closer to the edge than  $B/6$ , for a rectangular foundation, or  $r/2$ , for a circular foundation.

**3.2 Ultimate and design bearing strength and design bearing pressure**

**3.2.1** The design bearing pressure  $q_d$  shall be determined by dividing the design vertical forces (derived from combinations of factored vertical loads) by the effective area of the foundation. See Paragraph 3.3 for notation and the definition of effective area.

**3.2.2** The ultimate bearing strength  $q_u$  is that pressure, exerted on the ground by the *building* foundation, which causes the ground to fail by mobilisation of all available shear strength. It shall be evaluated using the provisions of Paragraph 3.3.

**3.2.3** The design bearing strength  $q_{dbs}$  shall be determined by multiplying the ultimate bearing strength by the appropriate *strength reduction factor* (see Paragraph 3.5.1).

**3.2.4** The design bearing pressure shall not exceed the design bearing strength.

**3.3 Ultimate limit state bearing strength for shallow foundations**

**3.3.1** The procedures specified in the following text apply to foundations of any size. The formulae are limited to soil profiles that for a depth beneath the underside of the foundation of at least two times the foundation width can be represented with single values for the density, angle of shearing

resistance, cohesion, and if appropriate, undrained shear strength.

Notation:

$A^l$	effective foundation area ( $m^2$ ). For a rectangular foundation $A^l = B^l L^l$ . For a circular foundation see Figure 2.	$Y$	the distance from the edge of the foundation, along the $y$ axis, to the point of application of the design vertical foundation load $V$ (m).
$B$	foundation breadth (m).	$Z$	the distance from the edge of a circular foundation, along the $z$ axis, to the point of application of the design vertical foundation load $V$ (m).
$B^l$	the smaller of $2(X + e_b)$ and $2(B - X - e_b)$ (see Figure 1) (m).	$c$	cohesion (kPa).
$D_e$	minimum horizontal distance from the edge of the underside of the foundation to the face of an adjacent downward slope (m).	$c^l$	effective stress cohesion (kPa).
$D_f$	depth to the underside of the foundation (m).	$e_b$	$M_l/V$ (positive when $R$ is further along the $x$ axis than $V$ , see Figure 1) (m).
$H$	design horizontal load, the resultant of the factored horizontal forces applied to the foundation (kN).	$e_c$	$M_c/V$ (positive when $R$ is further along the $z$ axis than $V$ , see Figure 2) (m).
$H_{uf}$	unfactored horizontal foundation load (kN).	$e_l$	$M_b/V$ (positive when $R$ is further along the $y$ axis than $V$ , see Figure 1) (m).
$L$	foundation length (m).	$q$	vertical total stress in ground adjacent to the foundation at depth $D_f$ (kPa).
$L^l$	the smaller of $2(Y + e_l)$ and $2(L - Y - e_l)$ (see Figure 1) (m).	$q^l$	vertical effective stress ( $\sigma_v^l$ ) in ground adjacent to the foundation at depth $D_f$ (kPa).
$M_b$	design moment applied about an axis parallel to the breadth direction of the foundation (kNm).	$q_d$	design bearing pressure = $V/A^l$ (kPa).
$M_c$	design moment applied to a circular footing (kNm).	$q_u$	ultimate bearing strength (kPa).
$M_l$	design moment applied about an axis parallel to the length direction of the foundation (kNm).	$q_{dbs}$	design bearing strength = $\Phi_{bc} q_u$ (kPa).
$N_{cr}$ , $N_q$ , $N_\gamma$	bearing strength factors.	$r$	radius of a circular foundation (m).
$P_p$	ultimate lateral resistance derived from passive earth pressure (kN).	$s_u$	undrained shear strength (kPa).
$R$	reaction on underside of foundation = $q_d A^l$ (kN).	$u$	pore water pressure at a given position in the soil profile (kPa).
$S$	ultimate shear strength between the base of the foundation and the ground (kN).	$u_f$	pore water pressure at depth $D_f$ (kPa).
$V$	design factored vertical foundation load (kN).	$x$	axis through design vertical foundation load $V$ in direction of foundation breadth. The axis starts at the foundation edge and is positive in the direction towards $V$ .
$V_{uf}$	unfactored vertical foundation load (kN).	$y$	axis through design vertical foundation load $V$ in direction of foundation length. The axis starts at the foundation edge and is positive in the direction towards $V$ .
$V^l$	effective design factored vertical load = $V - u_f A^l$ (kN).	$z$	axis through the centre of a circular foundation and the design vertical foundation load $V$ . The axis starts at the foundation edge and is positive in the direction towards $V$ .
$X$	the distance from the edge of the foundation, along the $x$ axis, to the point		



- $\gamma$  soil unit weight (kN/m<sup>3</sup>).
- $\gamma^l$  soil unit weight required for effective stress analysis for soil beneath the water table =  $\gamma - \gamma_w$  (kN/m<sup>3</sup>).
- $\Gamma$   $\gamma$  when the water table is deeper than 2B beneath the underside of the foundation and  $\gamma^l$  when the water table is above this.
- $\gamma_w$  water unit weight (kN/m<sup>3</sup>).
- $\Phi_{bc}$  *strength reduction factor* for bearing strength (see Paragraph 3.5.1).
- $\Phi_{pp}$  *strength reduction factor* for resistance derived from passive earth pressure (see Paragraph 3.5.1).
- $\Phi_{sl}$  *strength reduction factor* for sliding resistance (see Paragraph 3.5.1).
- $\phi$  angle of shearing resistance (degrees).
- $\phi^l$  effective stress angle of shearing resistance (degrees).
- $\sigma_v^l$  vertical effective stress at a given depth in the soil profile =  $\sum \gamma_i T_i - u$  where  $\gamma_i$  is the unit weight and  $T_i$  is the thickness of the  $i$ th soil layer above the depth at which  $\sigma_v^l$  is required (kPa).
- $\omega$  slope, below horizontal, of the ground adjacent to the edge of the foundation (degrees).

### 3.3.2 Ultimate bearing strength

The general expression for the ultimate bearing strength for a shallow foundation subject to vertical, shear, and moment loading is:

$$q_u = c\lambda_{cs}\lambda_{cd}\lambda_{ci}\lambda_{cg}N_c + q\lambda_{qs}\lambda_{qd}\lambda_{qi}\lambda_{qg}N_q + \frac{1}{2}\Gamma B^l\lambda_{\gamma s}\lambda_{\gamma d}\lambda_{\gamma i}\lambda_{\gamma g}N_\gamma$$

For undrained analysis ( $\phi = 0$ ) use the following form of the general equation:

$$q_u = s_u\lambda_{cs}\lambda_{cd}\lambda_{ci}\lambda_{cg}N_c + \lambda_{qg}q$$

For drained analysis use the following form of the general equation:

$$q_u = c^l\lambda_{cs}\lambda_{cd}\lambda_{ci}\lambda_{cg}N_c + q^l\lambda_{qs}\lambda_{qd}\lambda_{qi}\lambda_{qg}N_q + \frac{1}{2}\gamma^l B^l\lambda_{\gamma s}\lambda_{\gamma d}\lambda_{\gamma i}\lambda_{\gamma g}N_\gamma$$

The bearing strength factors are obtained from Figure 3 or the following equations:

$$N_q = e^{\pi \tan \phi} \tan^2 \left( 45 + \frac{\phi}{2} \right)$$

where  $e$  is the mathematical constant = 2.7183

$$N_c = (N_q - 1) \cot \phi \text{ for } \phi > 0, \text{ but has a value of } 5.14 \text{ for } \phi = 0$$

$$N_\gamma = 2(N_q - 1) \tan \phi$$

The  $\lambda$  factors in the above equation are:

a) Shape factors:  $\lambda_{cs}$ ,  $\lambda_{qs}$  and  $\lambda_{\gamma s}$

where:

$$\lambda_{cs} = 1 + \left( \frac{B^l}{L^l} \right) \left( \frac{N_q}{N_c} \right)$$

$$\lambda_{qs} = 1 + \left( \frac{B^l}{L^l} \right) \tan \phi$$

$$\lambda_{\gamma s} = 1 - 0.4 \left( \frac{B^l}{L^l} \right)$$

b) Depth factors:  $\lambda_{cd}$ ,  $\lambda_{qd}$  and  $\lambda_{\gamma d}$

where:

- for  $\phi = 0$  and  $\frac{D_f}{B^l} \leq 1$ :

$$\lambda_{cd} = 1 + 0.4 \left( \frac{D_f}{B^l} \right)$$

- for  $\phi = 0$  and  $\frac{D_f}{B^l} > 1$ :

$$\lambda_{cd} = 1 + 0.4 \tan^{-1} \left( \frac{D_f}{B^l} \right), \text{ where } \tan^{-1} \text{ is in radians}$$



**Figure 1: Bearing Strength Stress Block for a Shallow Rectangular Foundation Subject to Vertical Load and Moment**  
Paragraph 3.3.1

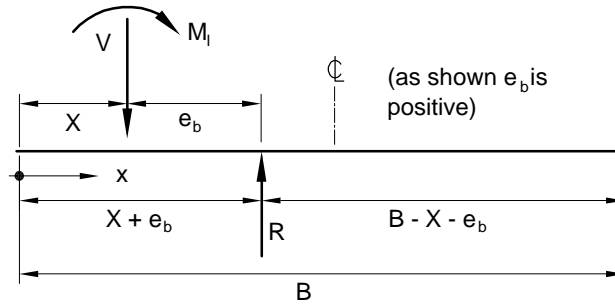

(a) Cross-section through foundation width

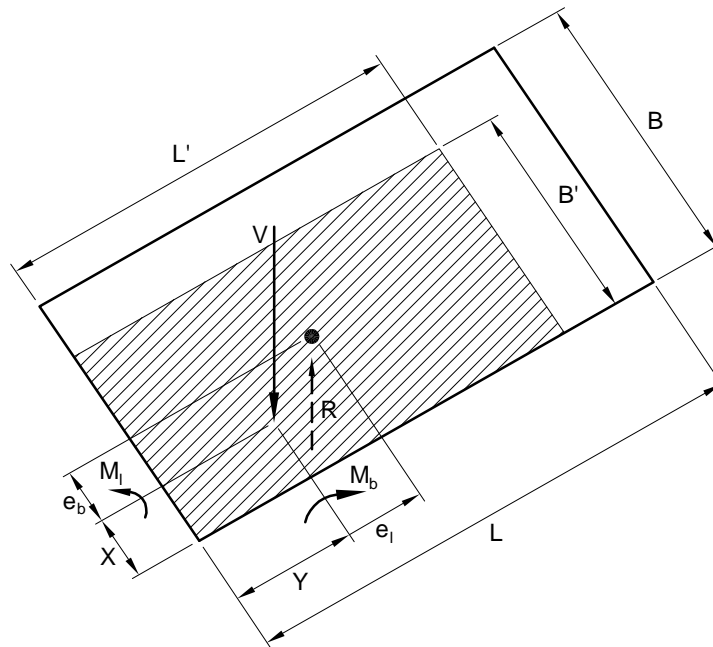

(b) Plan showing effective area of foundation

Notes:

1. Section (a) above drawn through foundation width. Section through foundation length similar.
2.  $B'$  is the smaller of  $2(X + e_b)$  and  $2(B - X - e_b)$ . Similarly  $L'$  is the smaller of  $2(Y + e_l)$  and  $2(L - Y - e_l)$ .
3.  $M$  can be applied anywhere on the foundation and does not have to be applied at the location of  $V$ .

**Figure 2: Effective Foundation Area for a Circular Foundation Subject to Vertical Load and Moment**  
Paragraph 3.3.1

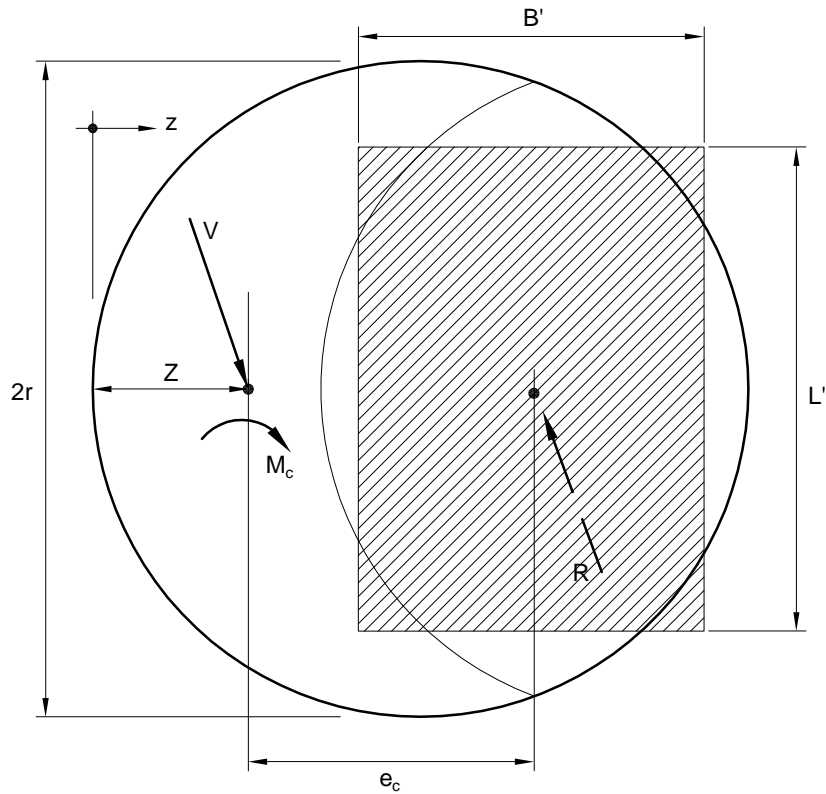

Notes

Effective area  $A'$  shall be represented by an equivalent rectangle of length  $L'$  and breadth  $B'$ , where:

$$A' = 2 r^2 \left[ \cos^{-1} (\xi) - \xi \sqrt{1 - \xi^2} \right] \quad (\text{Note: } \cos^{-1} (\xi) \text{ is in radians.})$$

$$B' = \left( \frac{1 - \xi}{1 + \xi} \right)^{0.25} \sqrt{A'}$$

$$L' = \left( \frac{1 + \xi}{1 - \xi} \right)^{0.25} \sqrt{A'}$$

where:

$$\xi = \frac{e_c + Z - r}{r} \quad \text{when } e_c + Z \geq r, \text{ or } \frac{r - e_c - Z}{r} \quad \text{otherwise}$$

Amend 8  
Dec 2008

- for  $\phi > 0$ :

$$\lambda_{qd} = \lambda_{qd} - \frac{(1 - \lambda_{qd})}{N_q \tan \phi}$$

$$\lambda_{\gamma i} = \left( 1 - \frac{H_{uf}}{V_{uf} + A'c' \cot \phi'} \right)^3$$

- for  $\frac{D_f}{B'} \leq 1$ :

$$\lambda_{qd} = 1 + 2 \tan \phi (1 - \sin \phi)^2 \left( \frac{D_f}{B'} \right)$$

$$\lambda_{ci} = \frac{\lambda_{qi} N_q - 1}{N_q - 1}$$

- for  $\frac{D_f}{B'} > 1$ :

$$\lambda_{qd} = 1 + 2 \tan \phi (1 - \sin \phi)^2 \tan^{-1} \left( \frac{D_f}{B'} \right),$$

where  $\tan^{-1}$  is in radians

- for all cases

$$\lambda_{\gamma d} = 1$$

- c) Load inclination factors:  $\lambda_{ci}$ ,  $\lambda_{qi}$  and  $\lambda_{\gamma i}$

where:

- for  $\phi = 0$

$$\lambda_{ci} = 0.5 \left( 1 + \sqrt{1 - \frac{H}{A'S_u}} \right)$$

$$\lambda_{qi} = 1$$

- for  $\phi > 0$

- for horizontal loading parallel to  $L^1$

$$\lambda_{qi} = \lambda_{\gamma i} = 1 - \frac{H_{uf}}{(V_{uf} + A'c' \cot \phi')}$$

$$\lambda_{ci} = \frac{\lambda_{qi} N_q - 1}{N_q - 1}$$

- for horizontal loading parallel to  $B^1$

$$\lambda_{qi} = \left( 1 - \frac{0.7 H_{uf}}{V_{uf} + A'c' \cot \phi'} \right)^3$$

- d) Ground inclination factors:  $\lambda_{cg}$ ,  $\lambda_{qg}$  and  $\lambda_{\gamma g}$

For horizontal ground  $\lambda_{cg} = \lambda_{qg} = \lambda_{\gamma g} = 1$

For inclined ground, the permitted slope (angle  $\omega$  below the horizontal) depends on soil angle of shearing resistance  $\phi$  and the distance  $D_e$  between the foundation and the slope face:

- where  $\phi \geq 0$  (drained analysis)

$v$  shall not be  $> \phi$

- where  $\phi = 0$  (undrained analysis)

$\omega$  shall not be  $> 45^\circ$

The ground inclination factors shall be:

- for  $D_e \leq 2B$

$$\lambda_{cg} = \lambda_{qg} = \lambda_{\gamma g} = 1$$

- for  $D_e < 2B$

$$\lambda_{cg} = 1 - \omega(1 - D_e/2B)/150$$

$$\lambda_{qg} = \lambda_{\gamma g} = (1 - \tan(\omega(1 - D_e/2B)))^2$$

### 3.3.3 Local shear

For sands with relative densities less than 40% and clays having liquidity indices greater than 0.7, the bearing strength shall be evaluated using  $0.67c$  for cohesion and  $\tan^{-1}(0.67 \tan \phi)$  for the angle of shearing resistance.

#### COMMENT:

The formulae in Paragraph 3.3.2 assume a general shear failure of the soil but for the soils specified in this Paragraph a local shear failure is likely.

**Figure 3: Bearing Strength Factors**  
Paragraphs 3.3.2 and 4.1.3

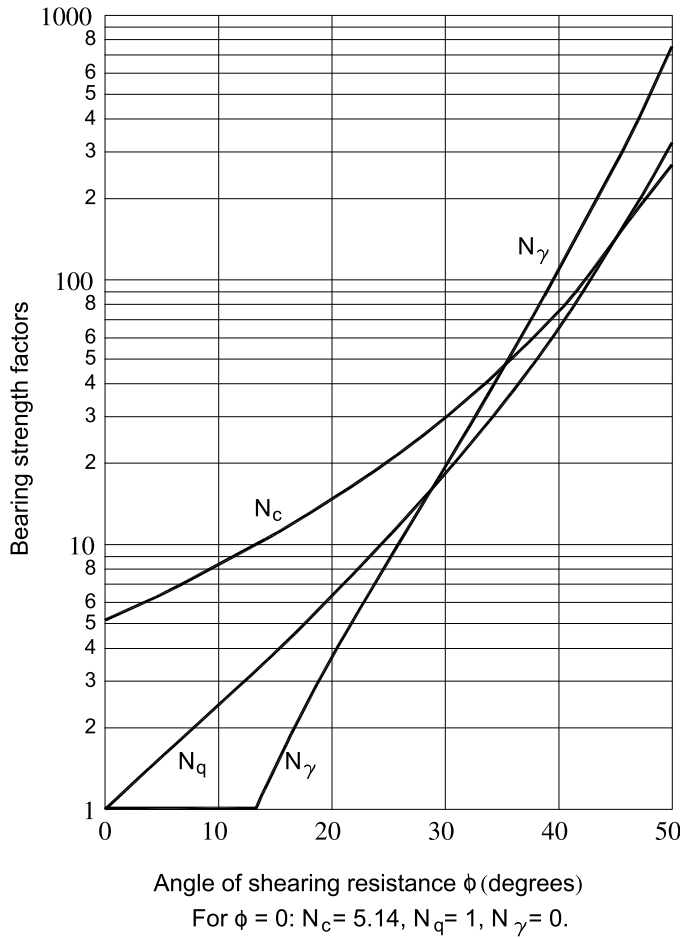

### 3.4 Ultimate limit state sliding resistance

**3.4.1** When the loading is not normal to the foundation base, foundations shall be checked for failure by sliding.

**3.4.2** The ultimate sliding resistance shall comprise the sum of the ultimate sliding strength between the base of the foundation and the ground, and any available passive earth pressure in the direction of sliding at the side of the foundation.

**3.4.3** Passive earth pressure shall not be considered if:

- a) For foundations in clay soils, it is possible that the clay could shrink away from the vertical faces of the foundation, or

- b) The possibility exists that the soil in front of the foundation may be removed by erosion or by building or landscaping work in the future.

**3.4.4** For drained conditions, the ultimate sliding strength shall be:

$$S = c'A' + V' \tan \delta'$$

The value of  $\delta'$  shall be taken as the angle of shearing resistance ( $\phi'$ ) of the foundation soil for cast-in-situ concrete foundations and  $0.67\phi'$  for smooth precast foundations.

**3.4.5** For undrained conditions, the ultimate sliding strength shall be:

$$S = A's_u$$

**3.4.6 Design sliding resistance**

The design horizontal load H shall not exceed the design sliding resistance, that is:

$$H \leq \Phi_{sl} S + \Phi_{pp} P_p$$

**3.5 Strength reduction factors**

**3.5.1** *Strength reduction factors* to be applied to shallow foundation design shall be within the range given in Table 1.

The designer shall nominate in the design the *strength reduction factors* chosen along with substantiation as to why the values chosen are considered appropriate. The values chosen shall be to the approval of the *territorial authority*.

**COMMENT:**

The value of the *strength reduction factor* used in design will depend on the designer’s knowledge of the site and the investigations undertaken. As a guide the lower end of the range will generally be appropriate when a limited site investigation is undertaken, average geotechnical properties are used, published correlations are used to obtain design parameters or there will be minimal *construction* control. The upper end of the range will generally be appropriate when a comprehensive site investigation and laboratory testing is undertaken, geotechnical properties are chosen conservatively, site specific correlations are used for design parameters and there will be careful *construction* control.

**4.0 Pile Foundations**

**4.0.1** The ultimate axial compressive pile strength for a single pile shall be determined using either or both of the following methods:

- a) Geotechnical calculation,
- b) Static load testing.

**COMMENT:**

Where piles are driven, a driving formula, such as the Hiley Formula, may provide a useful means of assessing the comparative strength of the individual piles at a particular site.

**4.0.2** Using geotechnical calculation, the ultimate axial compressive pile strength is the sum of the ultimate pile point-bearing resistance and the shaft resistance.

**4.0.3** When determined by static load testing, the ultimate axial compressive pile strength shall be taken as no more than that load which produces a penetration or pile settlement of 0.1 times the:

- a) *Nominal pile width* for driven piles,
- b) Bell diameter for belled piles,
- c) Estimated minimum bulb diameter for bulbed piles.

Suitable procedures for static load testing are described in AS 2159 Section 8, ASTM D1143 and BS 8004 Section 7.5.

**4.0.4** The design pile vertical or lateral strength of a single pile or pile group shall be determined by multiplying the ultimate strength by the appropriate *strength reduction factor* (see Paragraph 4.7.1). The design strength shall be greater than the applied factored loads.

<b>Table 1: Strength Reduction Factors for Shallow Foundation Design</b>	
Paragraph 3.5.1	
<b>Load combination</b>	<b>Strength reduction factor range</b>
<b>For bearing (<math>\Phi_{bc}</math>) and passive earth pressure (<math>\Phi_{pp}</math>):</b>	
Load combinations involving earthquake overstrength	0.80 – 0.90
All other load combinations	0.45 – 0.60
<b>For sliding (<math>\Phi_s</math>):</b>	
All load combinations, including earthquake overstrength	0.80 – 0.90

#### 4.1 Ultimate vertical strength of single piles

##### 4.1.1 Notation

$A_b$  area of pile base (m<sup>2</sup>).  
 $B_G$  width (between pile extremities) of a pile group (m).  
 $C$  circumference of the pile shaft (m).  
 $D_b$  diameter of the pile base (m).  
 $D_s$  diameter of the pile shaft (m).  
 $H$  design horizontal load applied to the pile head (factored applied loads) (kN).  
 $H_u$  ultimate lateral strength of a pile (kN).  
 $K_o$  the coefficient of earth pressure at rest =  $1 - \sin\phi'$  for loose sand and normally consolidated clay, and  $(1 - \sin\phi')\sqrt{OCR}$  for over-consolidated soils.  
 $K_p$  coefficient of passive earth pressure =  $(1 + \sin\phi')/(1 - \sin\phi')$ .  
 $K_s$  factor that expresses the horizontal effective stress at the pile/soil interface in terms of the vertical effective stress (see Table 2).  
 $L$  length of the pile shaft (m).  
 $L_G$  length (between pile extremities) of a pile group (m).  
 $M$  design moment applied to the pile head (factored applied moments) (kNm).  
 $M_{ult}$  ultimate moment strength of the pile shaft (kNm).  
 $OCR$  over-consolidation ratio being the previous maximum effective stress/current effective stress.

$R_d$  relative density as measured in accordance with Test 4.2.3 of NZS 4402.  
 $V_1$  ultimate strength of an individual pile in the group (kN).  
 $V_B$  ultimate strength of the block of soil enclosed within the pile group (kN).  
 $V_G$  ultimate strength of the group (kN).  
 $V_{bu}$  ultimate base resistance (kN).  
 $V_{su}$  ultimate shaft resistance (kN).  
 $V_u$  vertical pile strength (kN).  
 $W$  pile weight (part of the dead load) (kN).  
 $c_a$  the undrained adhesion (total stress) at the soil/shaft interface in a clay soil, or the adhesion at the boundary of a pile group =  $\alpha s_u$  (kPa).  
 $c'_a$  drained (effective stress) adhesion at the soil/shaft interface in a cohesive soil, or the adhesion at the boundary of a pile group (kPa).  
 $f$  for a free head pile, the distance above the ground surface at which the horizontal shear is applied (=  $M/H$ ); and for a restrained head pile, the distance above the ground surface at which the restraint is applied (m).  
 $f_o$  length of pile shaft assumed to be unsupported in cohesive soil =  $1.5D_s$  (m).  
 $g_c, g_l, g_s$  position along the pile shaft at which yielding occurs for piles in over-consolidated clay, normally consolidated clay, and sand respectively (m).  
 $n$  number of piles in the group.

**Table 2:** Values of  $\delta'$  and  $K_s$  for Pile Shafts  
Paragraphs 4.1.1 and 4.1.4 b) and c)

Pile material	$\delta'$	$K_s$	
		$R_d < 40\%$	$R_d > 40\%$
Steel	20°	0.5	1.0
Concrete	3 $\phi$ /4	1.0	2.0
Timber	2 $\phi$ /3	1.5	4.0

- q vertical stress in the soil at a depth equal to the base of the pile shaft, total stress for undrained analysis and effective stress for drained analysis (kPa).
- $s_u$  undrained shear strength (kPa).
- $\Phi_{pc}$  strength reduction factor for pile strength (for both vertical and lateral strength) (see Paragraph 4.7.1).
- $\alpha$  adhesion factor (see Figure 5).
- $\gamma$  unit weight of the soil in which the pile is embedded, chosen to give the total stresses for undrained loading in cohesive soil and effective stresses for drained loading ( $\gamma^l$  beneath the water table) (kN/m<sup>3</sup>).
- $\Gamma$   $\gamma$  when the water table is deeper than 2B beneath the underside of the foundation and  $\gamma^l$  when the water table is above this.
- $\delta^l$  drained angle of shearing resistance at the soil/shaft interface (see Table 2) (degrees).
- $\phi$  angle of shearing resistance (degrees).
- $\phi^l$  effective stress angle of shearing resistance (degrees).
- $\chi$  rate of increase in undrained shear strength with depth (kPa/m).
- $( )_{average}$  the average value of the parameter in the brackets taken over the length of the pile shaft.

#### 4.1.2 Vertical strength

The vertical pile strength is:

$$V_u = V_{su} + V_{bu}$$

#### 4.1.3 Base resistance

The undrained base resistance of piles in cohesive soil is:

$$V_{bu} = (9s_u + q) A_b$$

The drained base resistance, when the soil is sufficiently uniform to be represented by single values of  $c^l$ ,  $\phi^l$ ,  $s_u$  and  $\gamma$  for a distance of three pile shaft diameters above and below the pile base, shall be:

$$V_{bu} = (9c^l + q^l N_q + 0.6 D_b \Gamma N_\gamma) A_b$$

The values of  $N_q$  are taken from Figure 4 and  $N_\gamma$  from Figure 3.

#### 4.1.4 Shaft resistance

- a) For undrained loading of piles in cohesive soils:

$$V_{su} = (c_a)_{average} CL$$

where  $c_a = \alpha s_u$  and values for  $\alpha$  are given in Figure 5 for both driven and bored piles.

- b) For drained loading of piles in cohesive soils:

$$V_{su} = \{ (c_a^l)_{average} + (\sigma_v^l K_o \tan \delta^l)_{average} \} CL$$

The value of  $\delta^l$  is taken from Table 2.

- c) For drained loading of driven piles in cohesionless soils:

$$V_{su} = (\sigma_v^l K_s \tan \delta^l)_{average} CL$$

Values for  $K_s$  are given in Table 2.

#### 4.2 Column action

**4.2.1** Piles which stand unbraced in ground, water, or other material incapable of providing lateral support, shall be designed as columns.

**4.2.2** For a column partly embedded in the ground, the effective length is dependent upon the position of end restraint, which in turn is dependent upon the nature of the ground. End restraint shall be assumed at a depth of no less than:

- a) 3 times the *nominal pile width* in very stiff soil. (For clays an undrained shear strength greater than or equal to 100 kPa, and for sands a relative density greater than or equal to 50% shall be regarded as very stiff soil.)
- b) 6 times the *nominal pile width* in firm soil. (For clays an undrained shear strength between 50 and 100 kPa, and for sands a relative density between 30 and 50% shall be regarded as stiff soil.)
- c) 9 times the *nominal pile width* in other soil conditions.

**Figure 4:**  $N_q$  Values for Pile Foundations  
Paragraph 4.1.3

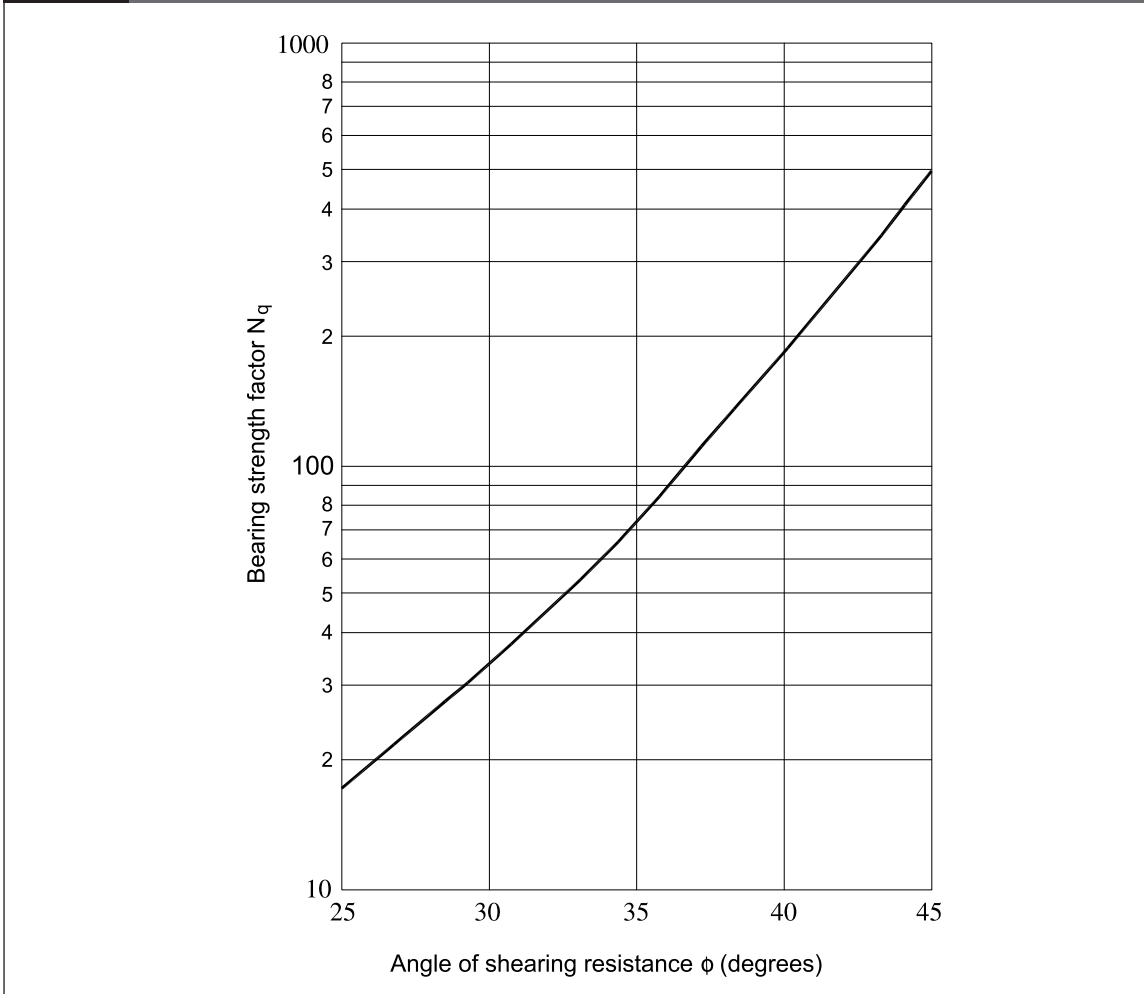

**Figure 5:** Adhesion Factor for Piles in Cohesive  
Paragraphs 4.1.1 and 4.1.4 a)

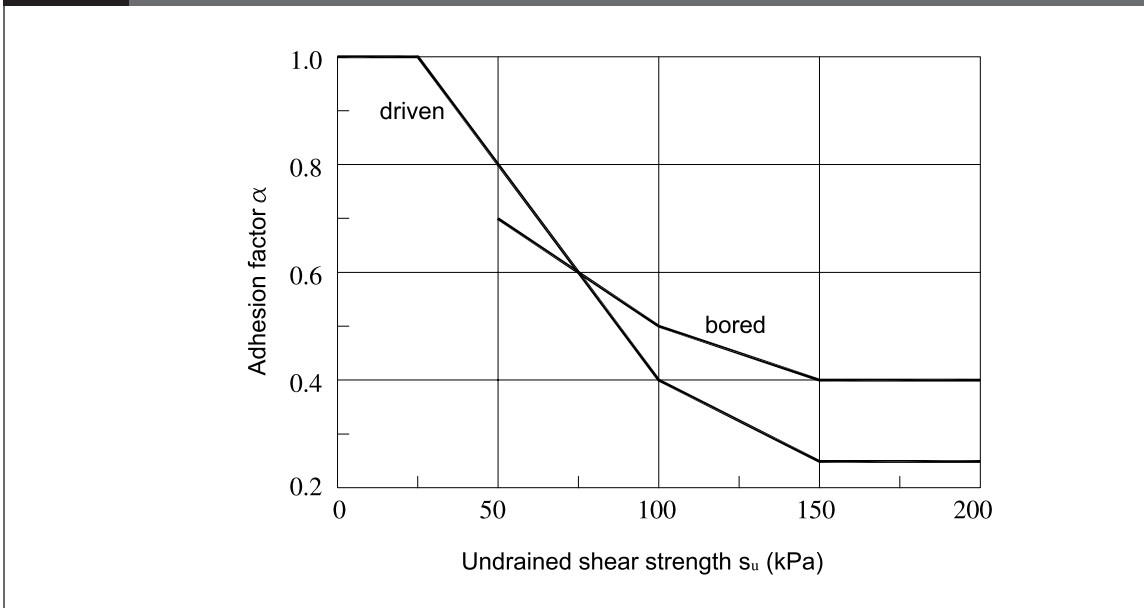



### 4.3 Ultimate lateral strength of single piles

**4.3.1** In the following paragraphs the terms “free head” and “restrained head” pile are used. Free head piles are classified as short and long. Restrained head piles are classified as short, intermediate and long. These terms are explained as follows:

- a) A free head pile has no restriction against head rotation when lateral displacement occurs. For a short free head pile the magnitude of the maximum bending moment in the embedded shaft is less than the ultimate moment strength of the pile shaft, and the ultimate strength is controlled by the embedment length of the pile shaft. The strength of a long free head pile is controlled by the ultimate moment strength of the pile shaft and not by the embedded length.
- b) For a restrained head pile subject to lateral displacement, the head rotation is constrained at the pile head by a fixing moment. A short pile is one in which the head moment and the maximum pile shaft moment are less than the ultimate moment strength of the pile section. For an intermediate length restrained head pile the head moment is equal to the ultimate strength of the pile shaft and elsewhere the shaft moments are less than  $M_{ult}$ . For a long restrained head pile the head moment and the maximum pile shaft moment each have a magnitude of  $M_{ult}$ .

#### 4.3.2 Undrained lateral strength of piles in cohesive soil having a constant undrained shear strength with depth

##### a) Free head piles

- i) short free head piles

The ultimate lateral strength of a short free head pile is given by:

$$H_u = 9s_u D_s \left[ \sqrt{2[(f + L)^2 + (f + f_o)^2]} - (L + 2f + f_o) \right]$$

Amend 9  
Sep 2010

The location, measured from the ground surface, of the maximum pile shaft moment is:

$$g_c = \frac{H_u}{9s_u D_s} + f_o$$

The maximum moment in the pile shaft is:

$$M_{max} = H_u \left( f + f_o + \frac{H_u}{18s_u D_s} \right)$$

Amend 5  
Jul 2001

If  $M_{max}$  is greater than  $M_{ult}$  the strength must be evaluated as for a long free head pile.

- ii) long free head piles

The ultimate lateral strength of a long free head pile

$$H_u = 3s_u D_s \left[ \sqrt{9(f + f_o)^2 + \frac{2M_{ult}}{s_u D_s}} - 3(f + f_o) \right]$$

The location of the maximum pile shaft moment ( $M_{ult}$ ) is obtained from the same equation as for the short pile.

##### b) Restrained head piles

- i) short restrained head piles

The ultimate lateral strength of a short restrained head pile is:

$$H_u = 9s_u D_s (L - f_o)$$

The pile head moment is:

$$M_{max} = 0.5H_u (L + 2f + f_o)$$

If  $M_{max}$  is greater than  $M_{ult}$  then the intermediate length case, ii) below, is appropriate.

- ii) intermediate restrained head piles

The ultimate lateral strength of an intermediate length restrained head pile is:

$$H_u = 9s_u D_s \left[ \sqrt{(L + 2f + f_o)^2 + (L - f_o)^2 + \frac{4M_{ult}}{9s_u D_s}} - (L + 2f + f_o) \right]$$

The location, measured from the ground surface, of the maximum pile shaft moment is:

$$g_c = \frac{H_u}{9s_u D_s} + f_o$$

The pile shaft moment at this depth is:

$$M_{max} = H_u \left[ \frac{H_u}{18s_u D_s} + f + f_o \right] - M_{ult}$$

If  $M_{max}$  calculated from this equation is greater than  $M_{ult}$  then the long case, iii) below, is appropriate.

- iii) long restrained head piles

The ultimate lateral strength of a long restrained head pile is:

$$H_u = 9s_u D_s \left[ \sqrt{(f + f_o)^2 + \frac{4M_{ult}}{9s_u D_s}} - (f + f_o) \right]$$

The location of the maximum pile shaft ( $M_{ult}$ ) is obtained from the same equation as for the intermediate length pile.

### 4.3.3 Undrained lateral strength of piles in normally consolidated cohesive soil

Normally consolidated cohesive soils have a linear increase in undrained shear strength with depth, starting with a value of zero at ground surface level.

**COMMENT:**

Only the long free head pile and intermediate and long restrained head piles are considered. Short piles are not normally used in such material.

The rate of increase in undrained shear strength with depth is denoted by  $\chi$  (kPa/m).

- a) **Long free head pile**

The ultimate lateral strength of a long free head pile is obtained by solving:

$$H_u \left[ \frac{2}{3} \sqrt{\frac{2H_u}{9D_s \chi}} + f \right] - M_{ult} = 0$$

The location, measured from the ground surface, of the maximum pile shaft moment ( $M_{ult}$ ) is:

$$g_l = \sqrt{\frac{2H_u}{9D_s \chi}}$$

- b) **Restrained head pile**

- i) intermediate restrained head piles

The ultimate lateral strength of an intermediate length restrained head pile is:

$$H_u = \frac{3D_s L^3 \chi}{2(f + L)} + \frac{M_{ult}}{f + L}$$

The location of the maximum pile shaft moment ( $M_{ult}$ ) is obtained from the same equation as for the long free head pile.

The pile shaft moment at this depth is:

$$M_{max} = H_u \left[ \frac{2}{3} \sqrt{\frac{2H_u}{9D_s \chi}} + f \right] - M_{ult}$$

If  $M_{max}$  calculated from this equation is greater than  $M_{ult}$  then the long case, ii) below, is appropriate.

- ii) long restrained head piles

The ultimate lateral strength of a long restrained head pile is obtained by solving:

$$H_u \left[ \frac{2}{3} \sqrt{\frac{2H_u}{9D_s \chi}} + f \right] - 2M_{ult} = 0$$

The location of the maximum pile shaft moment is obtained from the same equation as for the long free head pile.

#### 4.3.4 Drained lateral strength of piles in cohesionless soil

##### a) Free head piles

###### i) short free head piles

The ultimate lateral strength of a short free head pile is:

$$H_u = \frac{K_p D_s L^3 \gamma}{2(f + L)}$$

The location, measured from the ground surface, of the maximum pile shaft moment is:

$$g_s = \sqrt{\frac{2H_u}{3K_p \gamma D_s}}$$

The maximum pile shaft moment is:

$$M_{max} = H_u \left[ \frac{2}{3} \sqrt{\frac{2H_u}{3K_p D_s \gamma}} + f \right]$$

###### ii) long free head piles

The ultimate lateral strength of a long free head pile is obtained by solving the following equation:

$$H_u \left[ \frac{2}{3} \sqrt{\frac{2H_u}{3K_p D_s \gamma}} + f \right] - M_{ult} = 0$$

The location of the maximum pile shaft moment ( $M_{ult}$ ) is obtained from the same equation as for the short pile.

##### b) Restrained head piles

###### i) short restrained head piles

The ultimate lateral strength of a short restrained head pile is:

$$H_u = 1.5K_p D_s L^2 \gamma$$

The magnitude of the maximum pile head moment is:

$$M_{max} = H_u \left( \frac{2}{3}L + f \right)$$

If  $M_{max}$  is greater than  $M_{ult}$  then the intermediate length case, ii) below, is appropriate.

###### ii) intermediate restrained head piles

The ultimate lateral strength of an intermediate length restrained head pile is:

$$H_u = \frac{K_p D_s L^3 \gamma}{2(f + L)} + \frac{M_{ult}}{f + L}$$

The location, measured from the ground surface, of the maximum pile shaft moment is:

$$g_s = \sqrt{\frac{2H_u}{3K_p D_s \gamma}}$$

The pile shaft moment at this depth is:

$$M_{max} = H_u \left[ \frac{2}{3} \sqrt{\frac{2H_u}{3K_p D_s \gamma}} + f \right] - M_{ult}$$

If  $M_{max}$  calculated from this equation is greater than  $M_{ult}$  then the long case, iii) below, is appropriate.

iii) long restrained head piles

The ultimate lateral strength of a long restrained head pile is obtained by solving:

$$H_u \left[ \frac{2}{3} \sqrt{\frac{2H_u}{3K_p D_s \gamma}} + f \right] - 2M_{ult} = 0$$

The location of the maximum pile shaft moment is obtained from the same equation as is used for the intermediate length case.

#### 4.4 Pile groups

##### 4.4.1 Ultimate vertical strength of pile groups

The undrained vertical strength of a pile group considered as a single block in a cohesive soil is:

$$V_B = (9s_u + q) B_G L_G + 2 (B_G + L_G) L (c_a)_{average}$$

The drained strength of a pile group considered as a single block of soil is given by:

$$V_B = (c^l + q^l N_q + 0.6 B_G \Gamma N_\gamma) B_G L_G + 2 (B_G + L_G) L \{ (c_a^l)_{average} + (\sigma_v^l K_o \tan \delta^l)_{average} \}$$

The ultimate vertical strength of the group is determined from:

$$\frac{1}{V_G^2} = \frac{1}{n^2 V_1^2} + \frac{1}{V_B^2}$$

**4.4.2** If only part of an embedded friction pile length is in satisfactory material, the surface area calculated as providing frictional resistance shall be limited to the surface areas in contact with that material.

#### 4.5 Downdrag

**4.5.1** Downdrag may be generated when a pile shaft passes through a compressible soil layer. Downdrag shall be considered as dead load applied to the parts of the pile below the compressible layer. It shall be added to the imposed loadings and factored accordingly.

#### 4.6 Ultimate lateral strength of pile groups

**4.6.1** If piles are spaced at centre to centre intervals of less than 4.0 times the *nominal pile width*, the ultimate lateral pile strength shall be reduced. The reduced value shall be calculated as a percentage of the ultimate lateral pile strength for an isolated pile by linear interpolation between the two values given in Table 3.

#### 4.7 Strength reduction factors

**4.7.1** *Strength reduction factors* for design of ultimate vertical and lateral strengths in pile foundations shall be within the range given in Table 4.

The designer shall nominate in the design the *strength reduction factors* chosen along with substantiation as to why the values chosen are considered appropriate. The values chosen shall be to the approval of the *territorial authority*.

##### COMMENT:

The value of the *strength reduction factor* used in design will depend on the designer's knowledge of the site and the investigations undertaken. As a guide the lower end of the range will generally be appropriate when a limited site investigation is undertaken, average geotechnical properties are used, published correlations are used to obtain design parameters or there will be minimal *construction* control. The upper end of the range will generally be appropriate when a comprehensive site investigation and laboratory testing is undertaken, geotechnical properties are chosen conservatively, site specific correlations are used for design parameters and there will be careful *construction* control.

#### 5.0 Pile Types

##### 5.1 Concrete piles

**5.1.1** Precast concrete piles, including prestressed piles, shall withstand without damage or significant cracking, the stresses arising from manufacture, handling and transportation, in addition to those arising from driving and imposed loadings.

**5.1.2** Belled bases of cast-in-situ concrete piles shall be no less than 100 mm thick at the edge of the required base and, unless the bell is reinforced, the conical surfaces shall slope at an angle from the horizontal of no less than 60°.

**5.2 Steel piles**

**5.2.1** The design of steel piles shall be based on the nett steel section after deducting an appropriate thickness for future loss by corrosion.

This verification method does not describe a means of determining the amount of corrosion and proposals must be submitted to the territorial authority for approval.

**COMMENT:**

The amount deducted needs to take account of the aggressiveness of the soil. Further guidance can be found in AS 2159 Section 6.3 or the HERA Design and Construction Bulletin No 46.

**5.2.2** Allowance for corrosion loss need not be made for steel encased in concrete provided cover to the steel is no less than:

- a) 30 mm for prestressed concrete,
- b) 50 mm for precast concrete,
- c) 75 mm for cast-in-situ concrete.

**5.3 Timber piles**

**5.3.1** Timber piles shall comply with NZS 3605 or NZS 3603 as applicable, and be naturally durable or treated to the appropriate hazard level as recommended by NZS 3640.

**5.3.1.1** NZS 3605 shall be subject to the following modification:

**Clause 4.2.4.1** after “limitations for” add the word “verified”

Amend 9  
Sep 2010

<b>Table 3: Closely Spaced Piles, Design Lateral Resistance</b> Paragraph 4.6.1	
Pile spacing	% of isolated pile lateral resistance
4.0 x nominal pile width	100
1.0 x nominal pile width (palisade type wall)	25

<b>Table 4: Strength Reduction Factors for Deep Foundation Design</b> Paragraph 4.7.1	
Method of assessment of ultimate geotechnical strength for load combinations not involving earthquake overstrength	Range of values of $\Phi_{pc}$
Static load testing to failure	0.65 – 0.85
Static proof (not to failure) load testing	0.70 – 0.90
Static analysis using CPT (Cone Penetrometer Test) data	0.45 – 0.65
Static analysis using SPT (Standard Penetrometer Test) data in cohesionless soils	0.40 – 0.55
Static analysis using laboratory data for cohesive soils	0.45 – 0.55
Method of assessment of ultimate geotechnical strength for load combinations including earthquake overstrength	0.80 – 0.90



# Appendix A (Informative)

## A1.0 Site Investigation

---

### A1.1 General

**A1.1.1** No specific site investigation procedures are given in this document. The following information is provided for guidance only.

**A1.1.2** The ground conditions at the *building* site should be investigated to the extent considered necessary, by a person with appropriate expertise and experience, to provide essential site data for design of the proposed *building*. Both preliminary and detailed investigations may need to be undertaken.

### A1.2 Preliminary investigation

**A1.2.1** The preliminary site assessment may include investigation of:

- a) General land form, geology and any conditions likely to facilitate landslip, soil creep, shrinkage and expansion, or subsidence.
- b) Information available from records of previous *constructions*, excavations, fillings, *drains* and concealed works, on and adjacent to the site.
- c) History and behaviour of neighbouring *buildings* and details of their foundation types, depths and loadings.
- d) Potential for flooding (see also NZBC E1) and seasonal changes of soil characteristics.
- e) Seasonal, tidal or other natural groundwater changes.
- f) Presence of corrosive soil, groundwater and effluents (see also F1/VM1).

### A1.3 Detailed investigation

**A1.3.1** Detailed investigation may include:

- a) Test bores and excavations.
- b) Visual inspection.
- c) Laboratory and field testing of soil and rock samples.
- d) Advice from other people with relevant expertise.

### A1.4 Recording information

**A1.4.1** The description of the foundation material should be recorded. A suitable method for describing soil and rock is contained in "Guidelines for the field description of soils and rocks in engineering use" published by the New Zealand Geotechnical Society.

**A1.4.2** The site investigation record should include a site plan showing the locations of the test bores and excavations.

## Appendix B (Informative)

### B1.0 Serviceability Limit State Deformations (Settlement)

---

**B1.0.1** No specific method is given for determining foundation settlement. The following information is provided for guidance only.

**B1.0.2** Foundation design should limit the probable maximum differential settlement over a horizontal distance of 6 m to no more than 25 mm under serviceability limit state load combinations of AS/NZS 1170 Part 0, unless the structure is specifically designed to prevent damage under a greater settlement.

**B1.0.3** The basis for analysing settlement should be stated in the design. The analysis shall pay due consideration to:

- a) Size, shape and depth of the foundations,
- b) Proximity and influence of proposed and existing foundations,
- c) Variability of the ground,
- d) The presence of compressive or expansive materials,
- e) Rate of consolidation,
- f) Groundwater level,
- g) Extent of fill placed and ground removed when constructing the foundation, and
- h) Likelihood of liquefaction, internal erosion, soil collapse or other special feature.

Amend 8  
Dec 2008



# Appendix C (Informative) Design Example – Retaining Wall Foundation

## C1.0 Description of Wall, Limit States and Soil Properties

A gravity retaining wall backfilled with dry sand and founded on clay. In addition to static loading the effect of a horizontal earthquake acceleration of 0.20g is considered (there is no vertical acceleration component to the earthquake). The additional active thrust generated by the earthquake loading is assumed to act 0.6 times the height of the wall above foundation level. The proportions of the wall and the various soil properties are given in Figure C1.

There are six ultimate limit states to be considered:

- 1st Short term bearing capacity failure of the foundation beneath the wall,
- 2nd Short term sliding at foundation level,
- 3rd Short term bearing capacity failure under earthquake loading,
- 4th Short term sliding under earthquake loading,
- 5th Long term bearing capacity failure of the foundation beneath the wall,
- 6th Long term sliding at foundation level.

Short term analysis (both for the initial static loading of the foundation and the earthquake loading) is performed in terms of total stress and uses the undrained shear strength ( $s_u$ ) of the clay whilst the long term analysis is done using effective stresses and uses the strength parameters  $c'$  and  $\phi'$  for the clay (see Paragraph 2.0.6). The thrust from the sand backfill is based on effective stresses and is the same for all cases (see Paragraph 2.0.7).

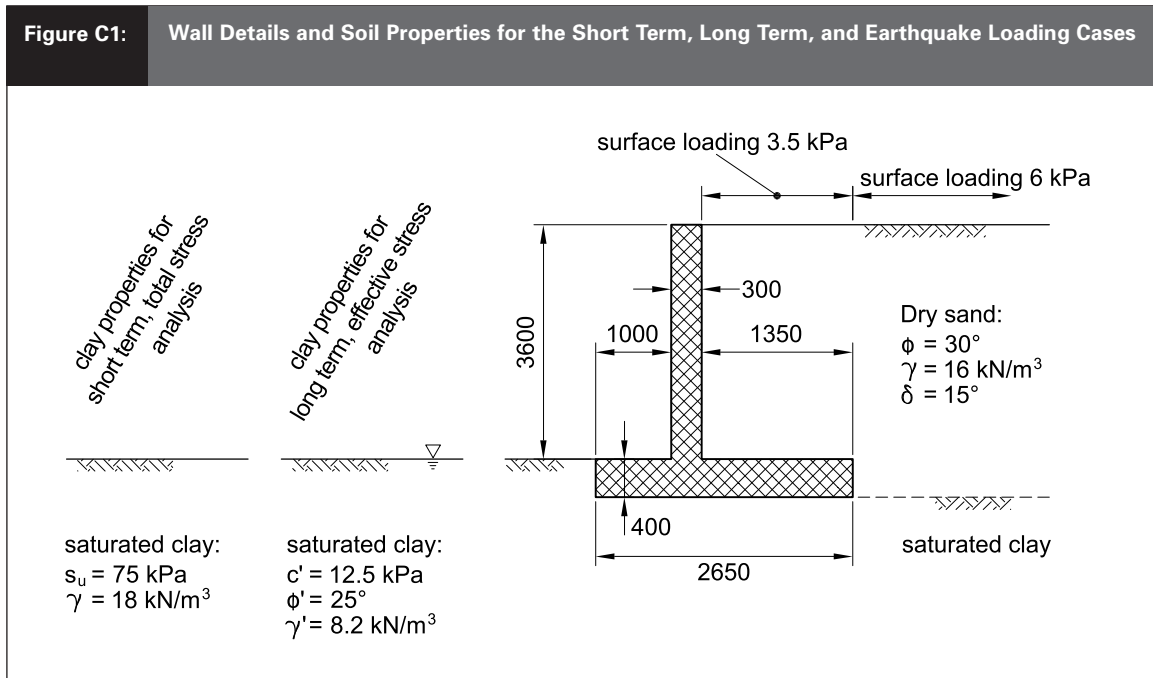

**C2.0 Earth Pressure Coefficients**

Active pressure coefficient for the sand backfill ( $\delta = \phi/2$ ) . . . . . 0.30

Active pressure coefficient for the sand backfill under EQ (0.20g) . . . . . 0.45

Passive earth pressure coefficient for clay ( $\phi = 25^\circ$  and  $\delta = \phi/2$ ) . . . . . 3.50

**C3.0 Load Factors and Strength Reduction Factors**

Load factor for dead loads that improve stability . . . . . 1.0

Load factor for static active earth thrusts . . . . . 1.6

Load factor for active earth thrusts under earthquake. . . . . 1.0

Strength reduction factor for static and EQ bearing failure ( $\Phi_{bc}$ ) . . . . . 0.45

Strength reduction factor for passive earth pressure ( $\Phi_{pp}$ ) . . . . . 0.45

Strength reduction factor for static and EQ sliding failure ( $\Phi_{sl}$ ) . . . . . 0.80

**C4.0 Notation**

The notation in Figure C2 is used to identify the weights and active thrusts on the wall, whilst in Figure C3 the actions on the foundation are shown.

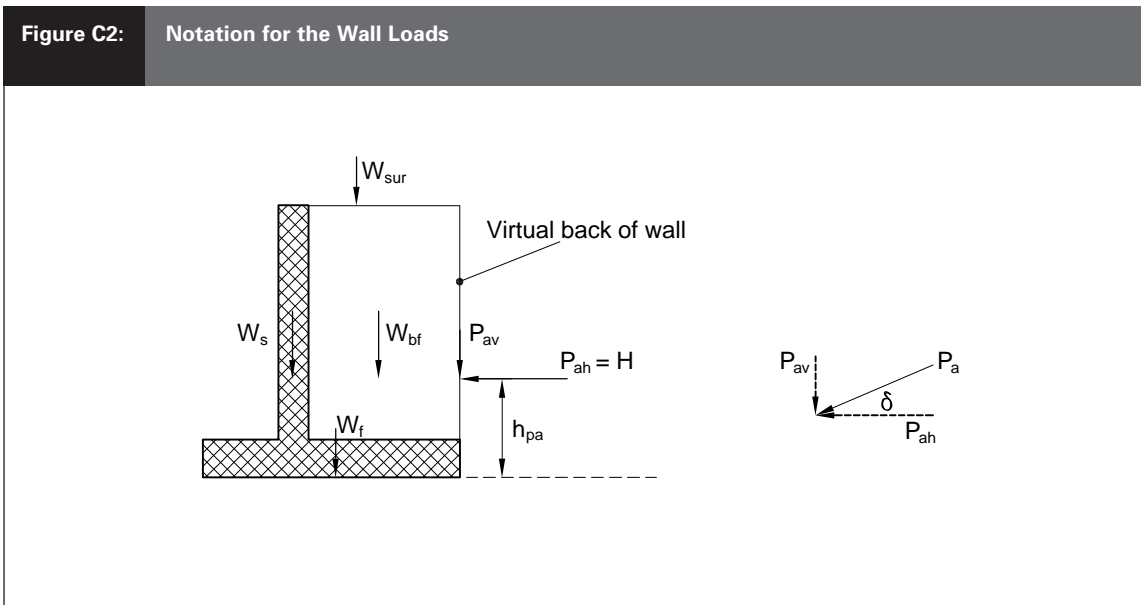

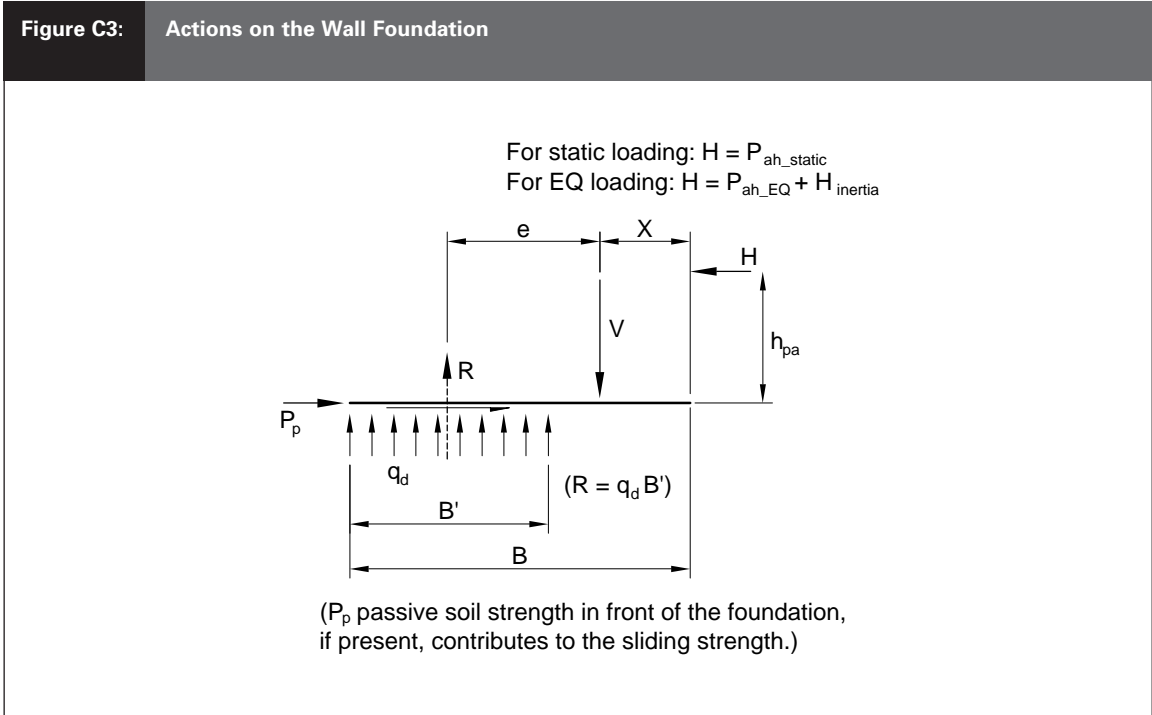

**C5.0 Loadings**

**C5.1 Active thrusts**

**Unfactored active thrusts:**

Static active thrust per metre from backfill (kN/m)	0.3 x 16 x 4 <sup>2</sup> /2	=	38.40
Static active thrust per metre from surcharge	0.3 x 6 x 4	=	7.20
Total static active thrust per metre of wall	38.4 + 7.2	=	45.60
EQ active thrust per metre from backfill	0.45 x 16 x 4 <sup>2</sup> /2	=	57.60
EQ active thrust per metre from surcharge	0.45 x 6 x 4	=	10.80
Total EQ active thrust per metre of wall	57.60 + 10.80	=	68.40
Difference between static and EQ active thrust from backfill	57.60 - 38.40	=	19.20

**Factor static active thrusts and find location of resultant:**

Factored static active thrust from backfill (kN/m)	38.40 x 1.6	=	61.44
Factored static active thrust from surcharge	7.2 x 1.6	=	11.52
Total factored active thrust per metre of wall	61.44 + 11.52	=	72.96
Take moments about heel to get location of active thrust (m)			
	$h_{pa\_static} = (38.40/3.0 + 7.20 \times 0.5) \times 4/45.60$	=	1.44
Horizontal component of static thrust (kN/m)	$H = P_{ah\_static} = 72.96 \times \cos 15$	=	70.47
Vertical component of static thrust (kN/m)	$P_{av\_static} = 72.96 \times \sin 15$	=	18.88

**Factor EQ active thrusts and find location of resultant:**

Factored EQ active thrust . . . . .  $57.60 \times 1 + 10.80 \times 1 = 68.40$

Take moments about heel to get location of active thrust (m)

$$h_{pa\_EQ} = (38.40/3.0 + 10.80 \times 0.5 + 19.20 \times 0.6) \times 4/68.40 = 1.74$$

Horizontal component of EQ thrust (kN/m) . . . . .  $P_{ah\_EQ} = 68.40 \times \cos 15 = 66.07$

Vertical component of EQ thrust (kN/m) . . . . .  $P_{av\_EQ} = 68.40 \times \sin 15 = 17.70$

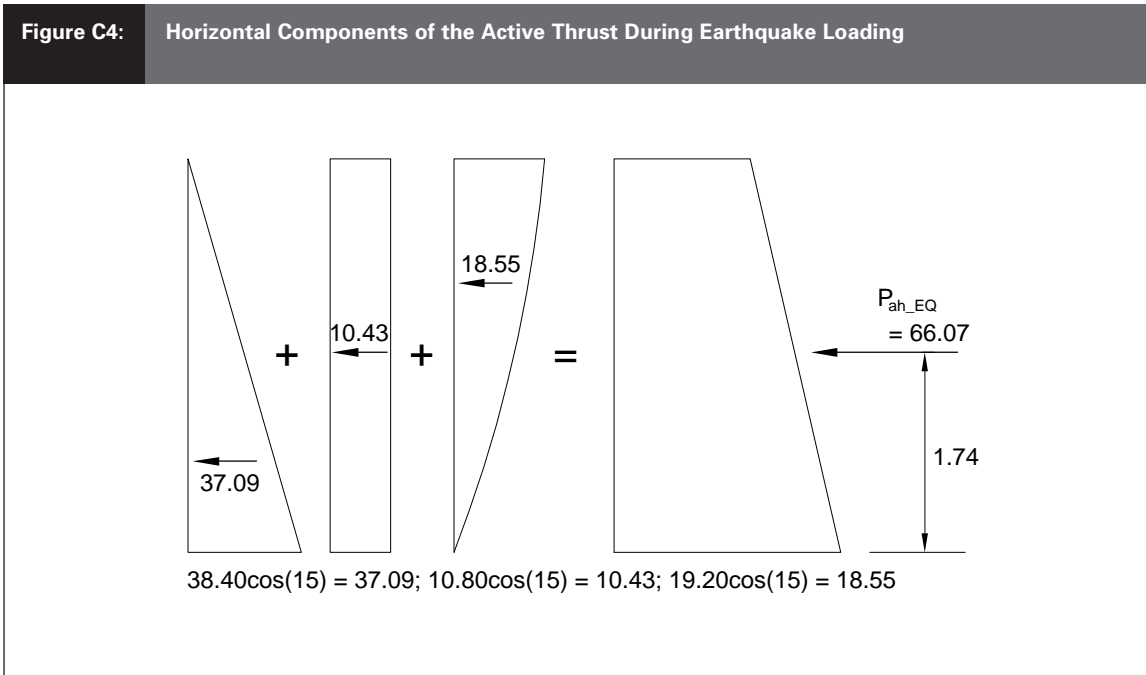

**C5.2 Weights (load factor 1.0) and resultant vertical forces on the wall**

Weight of wall stem . . . . .  $W_s = 3.6 \times 0.3 \times 25 = 27.00$

Weight of wall foundation . . . . .  $W_f = 2.65 \times 0.4 \times 25 = 26.50$

Weight of backfill above the heel of the wall. . . . .  $W_{bf} = 3.6 \times 1.35 \times 16 = 77.76$

Vertical force from surcharge above heel . . . . .  $W_{sur} = 3.5 \times 1.35 = 4.73$

Static vertical force on foundation (kN/m)

$$V = V_{static} = 18.88 + 27.00 + 26.50 + 77.76 + 4.73 = 154.87$$

EQ vertical force on foundation ( $k_h = 0.2$  and  $k_v = 0$ ) (kN/m)

$$V = V_{EQ} = 17.71 + 27.00 + 26.50 + 77.76 + 4.73 = 153.69$$

**C5.3 Horizontal forces applied to the foundation**

For the first, second, fifth and sixth ultimate limit states the horizontal force is:

$$H = P_{ah\_static} = 70.47 \text{ kN/metre length of wall}$$

For the third and fourth ultimate limit states the inertia of the wall is added to the active thrust to determine H:

Horizontal inertia force on the weight of the wall stem ( $W_s$ ) . . . . .	$27.00 \times 0.20$	=	5.40
Horizontal inertia force on the weight of the wall foundation ( $W_f$ ) . . . . .	$26.50 \times 0.20$	=	5.30
Horizontal inertia force on the weight of fill over heel ( $W_{bf}$ ) . . . . .	$77.76 \times 0.20$	=	15.55
Horizontal inertia force on the surcharge over heel ( $W_{sur}$ ) . . . . .	$4.73 \times 0.20$	=	0.95

$$H_{inertia} = 5.40 + 5.30 + 15.55 + 0.95 = 27.20$$

Take moments about heel to get location of resultant inertia force (m):

$$h_{inertia} = [(15.55 + 5.40) \times (0.4 + 3.6/2) + 5.30 \times 0.2 + 0.94 \times 4] / 27.20 = 1.87$$

$$H_{EQ} = P_{ah\_EQ} + H_{inertia} = 66.07 + 27.20 = 93.27 \text{ kN/metre of wall}$$

The weights of the various components of the wall and the horizontal inertia forces generated by the earthquake horizontal acceleration of 0.20g are given in Figure C5.

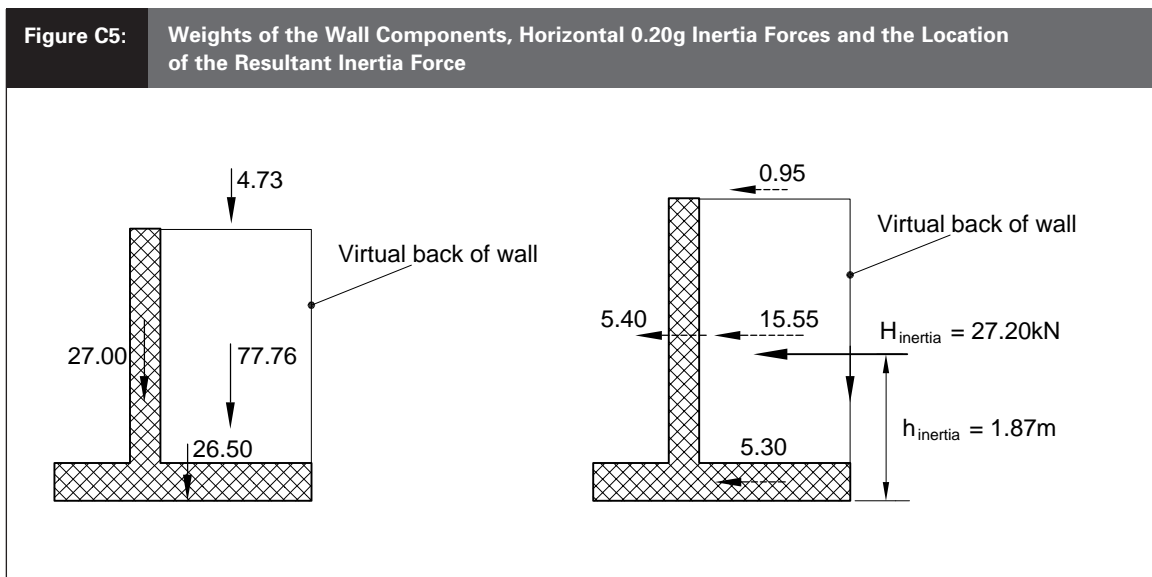

**C6.0 Surcharge Pressures at Toe**

Total stress surcharge pressure in front of wall (kPa) . . . . .  $q = \gamma_{clay} D_f = 18 \times 0.4 = 7.2$

Effective stress surcharge pressure in front of wall (kPa) . . . . .  $q' = \gamma'_{clay} D_f = 8.2 \times 0.4 = 3.3$

**C7.0 First Ultimate Limit State (short term static foundation bearing failure)**

Find X (location of V) by taking moments about heel.

Moment of the vertical forces:

$$(77.76 \times 1.35/2 + 4.73 \times 1.35/2 + 27.00 \times (1.35 + 0.15) + 26.50 \times 2.65/2) = 131.29$$

$$X = 131.29/154.87 = 0.848$$

Eccentricity:  $e = 70.47 \times 1.44/154.87 = 0.655$

$$B^1 = 2 \times (0.848 + 0.655) = 3.01$$

$$B^2 = 2 \times (2.65 - 0.848 - 0.655) = 2.29$$

$B^l$  is the smaller of  $B^1$  and  $B^2$ :

$B^l = 2.29$  (Distance from R to foundation edge =  $B^l/2 = 1.15 > B/6$  .'. ok (Paragraph 3.1.4))

Design bearing pressure:  $q_d = V/B^l = 154.87/2.29 = 67.6$  kPa

Determine ultimate bearing strength  $q_u = s_u \lambda_{cs} \lambda_{cd} \lambda_{ci} \lambda_{cg} N_c + \lambda_{qg} q$

For this case  $\phi = 0$ , so  $N_c = 5.14$ .  $\lambda_{cs}$  shall be taken as 1.0 as foundation is assumed to be long compared to its width. Also  $\lambda_{cg} = \lambda_{qg} = 1.0$  as the foundation is horizontal. Thus we need only to evaluate  $\lambda_{cd}$  and  $\lambda_{ci}$ .

$$\lambda_{cd} = 1 + 0.4 \times D_f/B^l = 1 + 0.4 \times 0.4/2.29 = 1.07$$

$$\lambda_{ci} = 0.5(1 + \alpha(1 - H/B^l s_u)) = 0.5 \times (1 + \alpha(1 - 70.47/2.29 \times 75)) = 0.88$$

$$q_u = s_u N_c \lambda_{cd} \lambda_{ci} + q = 75 \times 5.14 \times 1.07 \times 0.88 + 7.2 = 370.19$$

$$q_{dbs} = q_u \Phi_{bc} = 370.19 \times 0.45 = 166.6 \qquad q_d = 67.6 \qquad \text{Thus OK as } q_{dbs} > q_d$$

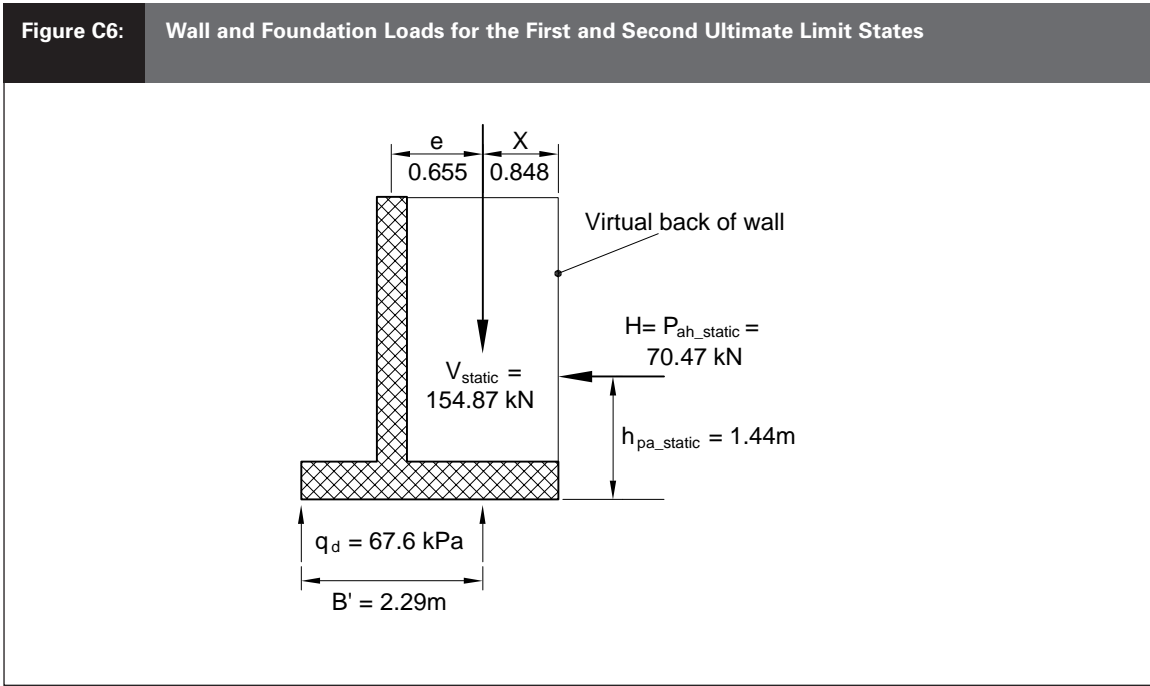

### C8.0 Second Ultimate Limit State (short term static foundation sliding failure)

The design sliding resistance is derived from the shear strength on the base and the passive resistance from the clay in front of the embedded part.

Ultimate shear strength:  $S = s_u B' = 75 \times 2.29 = 171.75$

Passive resistance:  $P_p = 2 s_u T_f + 0.5 \gamma_{\text{clay}} T_f^2$  where  $T_f$  is the foundation thickness  
 $= 2 \times 75 \times 0.4 + 0.5 \times 18 \times 0.4^2 = 61.44$

Design sliding resistance:  $S\Phi_{sl} + P_p\Phi_{pp} = 171.75 \times 0.8 + 61.44 \times 0.45 = 165.1$

$H = 70.5$

**Thus OK as  $S\Phi_{sl} + P_p\Phi_{pp} > H$**

### C9.0 Third Ultimate Limit State (short term foundation bearing failure under EQ)

Find X (location of V) by taking moments of vertical forces about heel.

Moment, as for the first ultimate limit state = 131.29

$X = 131.29/153.69 = 0.854$

To get eccentricity we need to add the moment of the horizontal inertia forces to that of the lateral thrust from the backfill:

$e = (66.07 \times 1.74 + 27.20 \times 1.87)/153.69 = 1.079$

$B'1 = 2 \times (0.854 + 1.079) = 3.87$

$B'2 = 2 \times (2.65 - 0.854 - 1.079) = 1.43$

$B'$  is the smaller of  $B'1$  and  $B'2$ :

$B' = 1.43$  (Distance from R to foundation edge =  $B'/2 = 0.72 > B/6 \therefore$  ok (Paragraph 3.1.4))

Design bearing pressure:  $q_d = V/B' = 153.69/1.43 = 107.46$  kPa

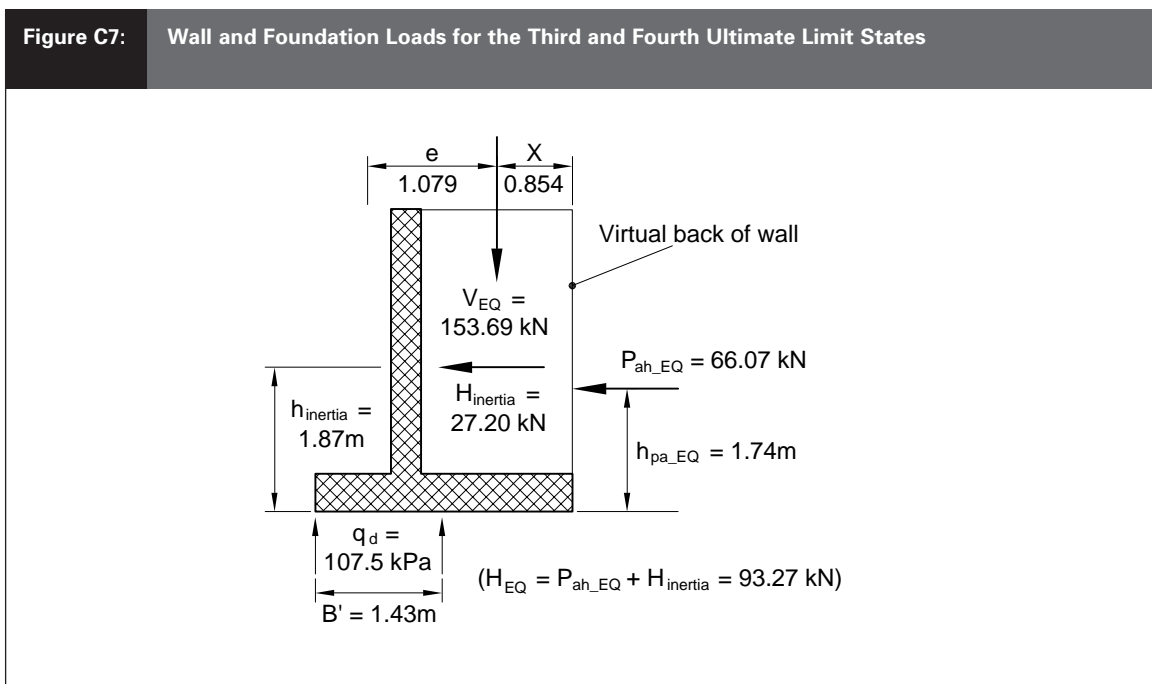

Determine ultimate bearing strength:

For this case  $\phi = 0$ , so  $N_c = 5.14$ .  $\lambda_{cs}$  shall be taken as 1.0 as foundation is assumed to be long compared to its width. Also  $\lambda_{cg} = \lambda_{qg} = 1.0$  as the foundation is horizontal. Thus we need only to evaluate  $\lambda_{cd}$  and  $\lambda_{ci}$ .

$$\lambda_{cd} = 1 + 0.4 \times D_f/B' = 1 + 0.4 \times 0.4/1.43 = 1.11$$

$$\lambda_{ci} = 0.5(1 + \sqrt{(1 - H/B's_u)}) = 0.5 \times (1 + \sqrt{(1 - 93.29/1.43 \times 75)}) = 0.68$$

$$q_u = s_u N_c \lambda_{cd} \lambda_{ci} + q = 75 \times 5.14 \times 1.11 \times 0.68 + 7.2 = 298.17$$

$$d_{bs} = q_u \Phi_{bc} = 298.17 \times 0.45 = 134.2$$

$$q_d = 107.5$$

Thus OK as  $d_{bs} > q_d$

### C10.0 Fourth Ultimate Limit State (short term foundation sliding failure under EQ)

The design sliding resistance is derived from the shear strength on the base and the passive resistance from the clay in front of the embedded part.

Ultimate shear strength:  $S = s_u B' = 75 \times 1.43 = 107.25$

Passive resistance:  $P_p = 2 s_u T_f + 0.5 \gamma_{clay} T_f^2 = 2 \times 75 \times 0.4 + 0.5 \times 18 \times 0.4^2 = 61.44$

Design sliding resistance:  $S\Phi_{sl} + P_p\Phi_{pp} = 107.25 \times 0.8 + 61.44 \times 0.45 = 113.5$

$$H = 93.3$$

Thus OK as  $S\Phi_{sl} + P_p\Phi_{pp} > H$

### C11.0 Fifth Ultimate Limit State (long term foundation bearing failure)

For this case we work in terms of effective stress.

The strength parameters for the clay become:  $c^l = 12.5$  kPa and  $\phi^l = 25^\circ$ . Furthermore the water table is at the ground surface in front of the wall so the buoyant density ( $18 - 9.81 = 8.2$  kN/m<sup>3</sup>) controls the effective stresses.

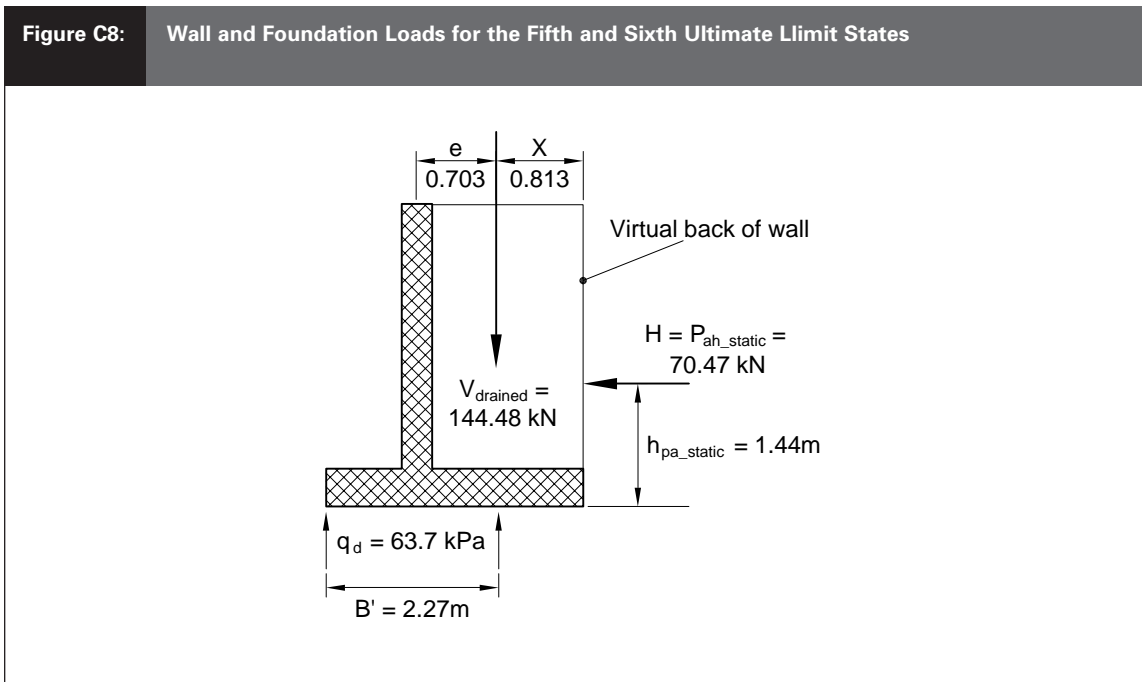



In addition there is a small positive water pressure acting on the underside of the wall which reduces the vertical load applied to the foundation.

$$u = 0.4 \times 9.81 = 3.92 \text{ and } V_{\text{drained}} = 154.87 - 3.92 \times 2.65 = 144.48$$

This has the effect of changing slightly  $X$  and  $e$ , hence  $B^I$  and  $q_d$ . We have from the first ultimate limit state the moment about the heel of the wall of the vertical forces = 131.29 kNm per metre length of the wall, so:

$$X = (131.29 - 3.92 \times 2.65 \times 2.65/2)/144.48 = 0.813$$

$$\text{Eccentricity of load: } e = 70.47 \times 1.44/144.48 = 0.703$$

$$B^I = 2 \times (2.65 - 0.813 - 0.703) = 2.27$$

$$\text{Design bearing pressure: } q_d = V_{\text{drained}}/B^I = 144.5/2.27 = 63.7 \text{ kPa}$$

For  $\phi$  equal to  $25^\circ$  the bearing capacity factors are:  $N_c = 21$ ,  $N_q = 11$  and  $N_\gamma = 9$ .

Determine ultimate bearing strength:

$$q_{u,\text{drained}} = c^I \lambda_{cs} \lambda_{cd} \lambda_{ci} \lambda_{cg} N_c + q^I \lambda_{qs} \lambda_{qd} \lambda_{qi} \lambda_{qg} N_q + 0.5 B^I \gamma^I \lambda_{\gamma s} \lambda_{\gamma d} \lambda_{\gamma i} \lambda_{\gamma g} N_\gamma$$

Shape factors  $\lambda_{cs}$ ,  $\lambda_{qs}$  and  $\lambda_{\gamma s}$  shall be taken as 1.0 as foundation is assumed to be long compared to its width. Also ground inclination factors  $\lambda_{cg}$ ,  $\lambda_{qg}$  and  $\lambda_{\gamma g} = 1.0$  as the foundation is horizontal. Thus we need only to evaluate depth and load inclination factors.

Depth factors:

$$\lambda_{qd} = 1 + 2 \tan \phi^I (1 - \sin \phi^I)^2 (D_f/B) = 1 + 2 \tan(25)(1 - \sin(25))^2 (0.4/2.27) = 1.05$$

$$\lambda_{cd} = \lambda_{qd} - (1 - \lambda_{qd})/N_q \tan \phi^I = 1.05 - (1 - 1.05)/11 \tan(25) = 1.04$$

$$\lambda_{\gamma d} = 1$$

Load inclination factors:

$$\lambda_{qi} = (1 - 0.7H/(V_{\text{drained}} + c^I B^I \cot \phi^I))^3 = (1 - 0.7 \times 70.47/(144.48 + 12.5 \times 2.27 \times \cot(25)))^3 = 0.46$$

$$\lambda_{ci} = (\lambda_{qi} N_q - 1)/(N_q - 1) = 0.40$$

$$\lambda_{\gamma i} = (1 - H/(V_{\text{drained}} + c^I B^I \cot \phi^I))^3 = (1 - 70.47/(144.48 + 12.5 \times 2.27 \times \cot(25)))^3 = 0.28$$

$$q_{u,\text{drained}} = c^I N_c \lambda_{cd} \lambda_{ci} + q^I N_q \lambda_{qd} \lambda_{qi} + 0.5 B^I \gamma^I N_\gamma \lambda_{\gamma d} \lambda_{\gamma i} \\ = 12.5 \times 21 \times 1.04 \times 0.40 + 3.3 \times 11 \times 1.05 \times 0.46 + 0.5 \times 9 \times 2.27 \times 8.2 \times 1 \times 0.31 = 152.70$$

$$q_{\text{dbs\_drained}} = q_{u,\text{drained}} \Phi_{bc} = 152.70 \times 0.45 = 68.7 \quad q_d = 63.7$$

**Thus OK as  $q_{\text{dbs\_drained}} > q_d$**

## C12.0 Sixth Ultimate Limit State (long term foundation sliding failure)

The design sliding strength is derived from the sliding resistance on the base and the passive resistance from the clay in front of the embedded part.

$$\text{Sliding resistance: } S_{\text{drained}} = c^I B^I + V_{\text{drained}} \tan \phi^I = 12.5 \times 2.27 + 144.48 \times \tan(25) = 95.75$$

$$\text{Passive resistance: } P_{p,\text{drained}} = 0.5 K_p \gamma^I T_f^2 + 2c^I T_f \sqrt{K_p} \\ = 0.5 \times 3.5 \times 8.2 \times 0.4^2 + 2 \times 12.5 \times 0.4 \times \sqrt{3.5} = 21.00$$

$$\text{Design sliding strength: } S \Phi_{sl} + P_p \Phi_{pp} = 95.75 \times 0.8 + 21.00 \times 0.45 = 86.05$$

$$H = 70.5$$

**Thus OK as  $S \Phi_{sl} + P_p \Phi_{pp} > H$**

### C13.0 Comments

---

The above calculations reveal that, for static loading, it is the long term case that is critical. Also for the short term cases the sliding strength derived from passive earth pressure in front of the embedded foundation is significant.

If the horizontal earthquake acceleration is increased much above 0.2g the third ultimate limit state becomes the limiting case as bearing failure is initiated. However, as explained in clauses 4.11.2.4 and C4.11.2.4 of NZS 4402: 1992, controlled sliding and tilting of the foundation during the passage of an earthquake is possible if the resulting post-earthquake permanent displacements are acceptable. The procedures and criteria for this approach are beyond the scope of this document.

# Acceptable Solution B1/AS4 Foundations

(Revised by Amendment 4)

No specific acceptable solution for foundations has been adopted for complying with the Performances of NZBC B1.



# Index B1/VM1/VM2/VM3/VM4 & AS1/AS2/AS3/AS4 (Revised by Amendment 4)

All references to Verification Methods and Acceptable Solutions are preceded by **VM** or **AS** respectively.

Amend 8  
Dec 2008

Amend 8  
Dec 2008

<b>Barriers</b> .....	see Timber barriers
<b>Buildings</b> .....	<b>AS3</b> 1.9.2, 1.9.4
building elements .....	<b>VM4</b> 2.0.3
earth buildings .....	<b>VM1</b> 8.0, <b>AS1</b> 4.0
masonry buildings .....	<b>AS3</b> 1.1.1
timber framed buildings .....	<b>AS3</b> 1.1.1
<b>Children</b> .....	<b>AS2</b> 1.0.2
<b>Chimneys</b> .....	<b>AS1</b> 1.2, 8.0, <b>AS3</b> 2.1
bracing units .....	<b>AS3</b> 1.9, 1.9.3, 1.9.6, Table 2
brick chimneys .....	<b>AS3</b> 1.1, 1.1.3 a) b), 1.2.1 a), 1.6.2 a), 1.7.1, 1.7.6, 1.8.1, 1.8.5 a), Figures 2, 3, 4, 7, Table 1
cantilever height .....	<b>AS3</b> 1.1.2
chimney bases .....	<b>AS3</b> 1.1.3 a), 1.6.1, 1.9.4 b)
chimney breasts .....	<b>AS3</b> 1.5, Table 1
chimney depth .....	<b>AS3</b> 1.1.3
chimney height .....	<b>AS3</b> 1.1.2
chimney liners .....	<b>AS3</b> 1.1.4
chimney lintels .....	<b>AS3</b> Table 1
chimney materials .....	<b>AS3</b> 1.8
chimney stacks .....	<b>AS3</b> 1.1.2, 1.6.1
chimney wall thicknesses .....	<b>AS3</b> 1.2, 1.2.1
chimney width .....	<b>AS3</b> 1.1.3
concrete chimneys .....	<b>AS3</b> 1.1.1, 1.1.3 a) c), 1.2.1 b) c), 1.6.2 a) b), 1.7.1, 1.7.13, 1.8.2, 1.8.5 b), Figures 4, 5, Table 1
concrete masonry .....	<b>AS3</b> 1.8.4
floor brackets .....	<b>AS3</b> 1.7.1, 1.7.3, 1.7.4, 1.7.5, 1.8.4, 1.9.4 b) c), Figure 6
foundations .....	<b>AS3</b> 1.1.2, 1.1.3 a), 1.3, 1.3.1, 1.3.2, 1.3.3, 1.7.4, 1.7.5, 1.8.4, Figure 1
foundation slabs .....	<b>AS3</b> 1.1.2, 1.3.2, 1.7.4, 1.7.5
gathers .....	<b>AS3</b> 1.6.1, 1.6.2, 1.7.5
packers .....	<b>AS3</b> 1.7.2, 1.7.6 c)
precast pumice concrete chimneys .....	<b>AS3</b> 1.1.1, 1.1.3 a) c), 1.2.1 c), 1.6.2 b), 1.7.1, 1.7.13, 1.8.3, 1.8.3 c), 1.8.5 c), Figures 5, 7, Table 1
compressive strength .....	<b>AS3</b> 1.8.3 c)
construction of .....	<b>AS3</b> 1.8.3
restraint .....	<b>AS3</b> 1.7, 1.7.1, 1.7.13, Figures 6, 7
roof brackets .....	<b>AS3</b> 1.7.1, 1.7.3, 1.7.4, Figure 6
roof ties .....	<b>AS3</b> 1.7.5
structural diaphragms .....	<b>AS3</b> 1.9.5

Chimneys (continued)  
 wall ties . . . . . **AS3** 1.7.5, 1.7.7, 1.7.8  
 closely spaced wall ties . . . . . **AS3** 1.7.5, 1.9.4 c)

**Concealed works** . . . . . **VM4** A1.2.1 b)

**Concrete** . . . . . see Design, concrete

**Design**

aluminium . . . . . **VM1** 7.0  
 concrete . . . . . **VM1** 3.0  
 Amend 8 | concrete masonry . . . . . **VM1** 4.0, **AS1** 2.0, **AS3** 1.3.3  
 Dec 2008 |  
 Amend 8 | drains . . . . . see Drains  
 Dec 2008 | earth building . . . . . **VM1** 8.0  
 foundations . . . . . see Foundations  
 loadings . . . . . **VM1** 2.0  
 earthquake . . . . . **VM1** 1.0, 2.0, **AS3** 1.9, Table 2  
 limit state . . . . . **VM1** 2.0, 7.1

Amend 8 | siteworks . . . . . **VM1** 10.0  
 Dec 2008 | steel . . . . . **VM1** 5.0  
 Amend 8 | strength reduction factor . . . . . **VM4** 2.0.1, 3.5.1, 4.7, Tables 1, 4  
 Dec 2008 | structural design actions Standards . . . . . **VM1** 2.0  
 timber . . . . . **VM1** 6.0, **AS1** 3.0  
 see also Timber barriers  
 windows . . . . . see Windows

**Drains** . . . . . **VM1** 11.0, **AS1** 6.0

**Earth retaining structures** . . . . . **VM4** 2.0.3

Amend 8 |  
 Dec 2008 |  
**Effluents** . . . . . **VM4** A1.2.1 f)

Amend 8 |  
 Dec 2008 |  
**Floor** . . . . . **AS2** 2.1.1

Amend 8 |  
 Dec 2008 |  
**Foundations** . . . . . **VM1** 9.0, **VM4**

design parameters  
 continuous vibration . . . . . **VM4** 1.0.6  
 depth . . . . . **VM4** 2.0.4  
 ground stability . . . . . **VM4** 1.0.4  
 long-term loading . . . . . **VM4** 2.0.6  
 short-term loading . . . . . **VM4** 2.0.6  
 serviceability deformations . . . . . **VM4** 1.0.3, Appendix B

Foundations (continued)

pile foundations . . . . .	<b>VM4</b> 4.0
belled piles . . . . .	<b>VM4</b> 4.0.3 b), 5.1.2
bulbed piles . . . . .	<b>VM4</b> 4.0.3 c)
concrete piles	
cast-in-situ . . . . .	<b>VM4</b> 3.4.4
precast . . . . .	<b>VM4</b> 3.4.4, 5.1.1
downdrag . . . . .	<b>VM4</b> 4.5
nominal width . . . . .	<b>VM4</b> 4.0.3, 4.2, 4.6.1
notation . . . . .	<b>VM4</b> 4.1.1, Figure 5, Table 2
pile driving . . . . .	<b>VM4</b> 5.1.1
pile driving formula . . . . .	<b>VM4</b> 4.0.1
pile groups	
design pile lateral strength . . . . .	<b>VM4</b> 4.0.4
design pile vertical strength . . . . .	<b>VM4</b> 4.0.4
ultimate lateral strength . . . . .	<b>VM4</b> 4.6.1, Table 3
ultimate vertical strength . . . . .	<b>VM4</b> 4.4.1
single piles	
base resistance . . . . .	<b>VM4</b> 4.1.3, Figures 3, 4
column action design . . . . .	<b>VM4</b> 4.2
design pile vertical strength . . . . .	<b>VM4</b> 4.0.4
design pile lateral strength . . . . .	<b>VM4</b> 4.0.4
lateral strength . . . . .	<b>VM4</b> 4.3
drained cohesionless soil . . . . .	<b>VM4</b> 4.3.4
free head pile . . . . .	<b>VM4</b> 4.3.2 a), 4.3.3 a), 4.3.4 a)
restrained head pile . . . . .	<b>VM4</b> 4.3.2 b), 4.3.3 b), 4.3.4 b)
undrained cohesive soil . . . . .	<b>VM4</b> 4.3.2
undrained consolidated soil . . . . .	<b>VM4</b> 4.3.3
shaft resistance . . . . .	<b>VM4</b> 4.1.4, Figure 5, Table 2
ultimate axial compression . . . . .	<b>VM4</b> 4.0.1, 4.0.2, 4.0.3
vertical strength . . . . .	<b>VM4</b> 4.1.2
strength reduction factors . . . . .	<b>VM4</b> 4.7, Table 4
types	
concrete . . . . .	<b>VM4</b> 5.1.1, 5.1.2
steel . . . . .	<b>VM4</b> 5.2.1, 5.2.2
timber . . . . .	<b>VM4</b> 5.3
shallow foundations . . . . .	<b>VM4</b> 3.0
design bearing pressure . . . . .	<b>VM4</b> 3.2.1, 3.2.4
design bearing strength . . . . .	<b>VM4</b> 3.2.3
design sliding resistance . . . . .	<b>VM4</b> 3.4.6
local shear . . . . .	<b>VM4</b> 3.3.3
moment loading . . . . .	<b>VM4</b> 3.1.4
notation . . . . .	<b>VM4</b> 3.3.1, Figures 1, 2
soils . . . . .	<b>VM4</b> 3.1.2, 3.4.3
strength reduction factors . . . . .	<b>VM4</b> 3.5, Table 1
surcharge . . . . .	<b>VM4</b> 3.1.3
ultimate bearing strength . . . . .	<b>VM4</b> 3.1.1, 3.2.2, 3.3.2, Figure 3
ultimate sliding resistance . . . . .	<b>VM4</b> 3.4.2
ultimate sliding strength . . . . .	<b>VM4</b> 3.4.4, 3.4.5
see also Chimneys, foundations	

**Geology** ..... **VM4** A1.2.1 a)

**Glazing** ..... **AS1** 7.0

**Ground**  
good ground ..... **AS3** 1.3.2

**Ground conditions** ..... **VM4** 1.0.2, Appendix A

**Ground water** ..... **VM4** 1.0.2, Appendices A, B  
conditions ..... **VM4** 1.0.2  
seasonal changes ..... **VM4** A1.2.1 e)  
tidal changes ..... **VM4** A1.2.1 e)

**Hearths** ..... **AS3** 1.4, 2.2, 2.2.1, 2.2.2, 2.2.3  
hearth slabs. .... **AS3** 2.2, 2.2.1, 2.2.2, 2.2.3

**Hot dip galvanising** ..... **AS2** 1.0.5 b), **AS3** 1.8.6

**Landslip** ..... **VM4** A1.2.1 a)

**Loadings** ..... see Design, loadings

**Masonry** ..... see Design, concrete masonry

**Materials** ..... **AS3** 1.8  
chimneys. .... see Chimneys, chimney material  
Standards ..... **VM1** 1.0

**Piles** ..... see Foundations

**Reinforcing steel** ..... **AS3** 1.3.2 b) c), 1.4, 1.6, 1.6.1,  
1.6.2, 1.8.5, 2.2.1 a), Table 1

**Settlement** ..... **VM4** 4.0.3, Appendix B  
differential settlement. .... **VM4** B1.0.2  
factors affecting settlement ..... **VM4** B1.0.3

**Site characteristics** ..... **VM4** Appendix A

**Site investigations** ..... **VM4** 3.5.1, 4.7.1, Appendix A  
detailed investigations. .... **VM4** A1.3  
preliminary investigations ..... **VM4** A1.2  
recording information ..... **VM4** A1.4

**Siteworks** ..... see Design, siteworks

**Slope stability** ..... **VM4** 1.0.4

**Small chimneys** ..... see Chimneys

**Soil properties** ..... **VM4** 1.0.5, 2.0.6, 2.0.7, Appendix A

**Soil shrinkage and expansion** ..... **VM4** 3.1.2, 3.4.3, A1.2.1 a)

**Soils**  
adverse moisture conditions. .... **VM4** 1.0.2

Amend 8  
Dec 2008

Amend 8  
Dec 2008



**Solid fuel burning domestic appliances** ..... **AS3** 2.0

**Steel** ..... see Design, steel

**Stucco** ..... **AS1** 5.0

**Subsidence** ..... **VM4** A1.2.1 a)

**Timber** ..... see Design, timber

**Timber barriers** ..... **AS1** 1.2, 9.0, **AS2** 1.0  
alternative details ..... **AS2** 2.7  
balusters ..... **AS2** 2.1.1, 2.2.1, 2.2.2, 2.3, 2.4.1, 2.7.1, 2.7.2,  
Figures 2, 3, 4, Tables 1, 2, 3, 5  
connections ..... **AS2** 1.0.5 b) c), 2.2.2, 2.3.3 to 2.3.9,  
2.5.2, 2.5.3, 2.7.2, Figures 2, 3, 4, Tables 3, 4  
construction ..... **AS2** 2.0  
dimensions of timber ..... **AS2** 1.0.4  
exposed to the weather ..... **AS2** 1.0.5  
joists ..... **AS2** 2.1.1, 2.3.8  
    blocking ..... **AS2** 2.1.1, 2.3.4, 2.3.6, 2.3.8  
    boundary joists ..... **AS2** 2.1.1, 2.3.2, 2.3.4, 2.3.5, Figure 4  
    end joists ..... **AS2** 2.3.2, 2.3.4, 2.3.6, Figure 4  
    intermediate joists ..... **AS2** 2.3.2, 2.3.3, Figure 3, Table 3  
materials ..... **AS2** 1.0.3  
moisture contents ..... **AS2** 2.6.1  
palings ..... **AS2** 2.1.1, 2.5  
rails  
    bottom rails ..... **AS2** 2.1.1, 2.4, 2.5.2, 2.7.2, Table 5  
    top rails ..... **AS2** 2.1.1, 2.2, 2.3.1, 2.5.1, 2.5.3,  
    2.7.1, 2.7.2, Figure 1, Tables 1, 2

**Timber connections** ..... **AS2** 1.0.5 b) c)

**Windows** ..... **VM1** 12.0  
glazing ..... **AS1** 7.0

