



MINISTRY OF BUSINESS,
INNOVATION & EMPLOYMENT
HĪKINA WHAKATUTUKI

ARCHIVED

Effective until 1 November 2023
Replaced by B1 Structure First Edition Amendment 21

Acceptable Solutions and Verification Methods

For New Zealand Building Code Clause
B1 Structure



Status of Verification Methods and Acceptable Solutions

Verification Methods and Acceptable Solutions are prepared by the Ministry of Business, Innovation and Employment in accordance with section 22 of the Building Act 2004. Verification Methods and Acceptable Solutions are for use in establishing compliance with the New Zealand Building Code.

A person who complies with a Verification Method or Acceptable Solution will be treated as having complied with the provisions of the Building Code to which the Verification Method or Acceptable Solution relates. However, using a Verification Method or Acceptable Solution is only one method of complying with the Building Code. There may be alternative ways to comply.

Defined words (italicised in the text) and classified uses are explained in Clauses A1 and A2 of the Building Code and in the Definitions at the start of this document.

Enquiries about the content of this document should be directed to:



**MINISTRY OF BUSINESS,
INNOVATION & EMPLOYMENT**
HĪKINA WHAKATUTUKI

Ministry of Business, Innovation and Employment
PO Box 1473, Wellington 6140
Telephone 0800 242 243
Email: info@building.govt.nz

**Verification Methods and Acceptable Solutions
are available from www.building.govt.nz**

New Zealand Government

ISBN (online) 987-1-99-100871-8

© Ministry of Business, Innovation and Employment 2021

This document is protected by Crown copyright, unless indicated otherwise. The Ministry of Business, Innovation and Employment administers the copyright in this document. You may use and reproduce this document for your personal use or for the purposes of your business provided you reproduce the document accurately and not in an inappropriate or misleading context. You may not distribute this document to others or reproduce it for sale or profit.

The Ministry of Business, Innovation and Employment owns or has licences to use all images and trademarks in this document. You must not use or reproduce images and trademarks featured in this document for any purpose (except as part of an accurate reproduction of this document) unless you first obtain the written permission of the Ministry of Business, Innovation and Employment.

Document Status

The most recent version of this document (Amendment 20), as detailed in the Document History, is approved by the Chief Executive of the Ministry of Business, Innovation and Employment. It is effective on 29 November 2021 and supersedes all previous versions of this document. The previous Amendment 19 can be used to show compliance until 2 November 2022 and can be used for building consent applications submitted before 3 November 2022. People using this document should check for amendments on a regular basis. The Ministry of Business, Innovation and Employment may amend any part of any Verification Method or Acceptable Solution at any time. Up-to-date version of Verification Methods and Acceptable Solutions are available from www.building.govt.nz

B1: Document History			
	Date	Alterations	
First published	July 1992		
Amendment 1	September 1993	p. ix–xii, References p. 1, 1.3, 1.4.1–1.4.3, 2.1, 2.2, 3.1–3.3, 4.1, 5.1 p. 2, 6.1, 6.2, 8.1, 9.1 p. 4, 11.1, 12.1 p. 5, 1.2, 2.1, 2.2, 3.1, 3.2,s 4.1, 4.2, 6.1, 6.2, 7.1	p. 9, 1.0.1, 1.0.5 b) c) p. 10, 2.3.5 p. 13, Figure 4 p. 14, 2.3.6 p. 16, 2.3.8, 2.3.9 p. 34, Table 1 p. 47, 1.0.1 pp. 49–54, Index
Amendment 2	19 August 1994	pp. i and ii, Document History pp. vii and viii, Contents pp. x and xi, References p. xiv, Definitions p. 1, 1.4.2, 5.1 p. 2, 6.1 p. 5, 1.3, 3.1, 4.1 p. 6, 7.1 p. 10, 2.3.5 p. 12, Figure 3 p. 13, Figure 4 p. 14, 2.3.6, 2.3.7	p. 15, Tables 4 and 5 p.16, 2.4.1 p. 21, Figure 2 p. 22, Figure 3 p. 32, 2.2.4 p. 33, 1.0.2 p. 34, 3.2.1, Table 1 p. 35, 4.1, 4.1.2, 4.1.3, 4.2.1, 4.2.2, 4.3, 4.3.1, 5.0.1, Table 2 p. 36, 6.1.2, 7.1, 7.1.1 p. 37, 7.3.4 pp. 49, 50, 51, 54, Index
Reprinted incorporating Amendments 1 and 2	October 1994		
Amendment 3	1 December 1995	p. ii, Document History p. ix, References p. 1, 3.1	p. 5, 6.2 p. 50, Index
Reprinted incorporating Amendments 1, 2 and 3	July 1996		
Amendment 4	1 December 2000	p. ii, Document History pp. vii and viii, Contents pp. ix – xii, Revised References pp. xiii and xiv, Definitions	pp. 1–4A, Revised B1/VM1 pp. 5 and 6, Revised B1/AS1 pp. 33–63, Revised B1/VM4 p. 65, Revised B1/AS4 pp. 67–72, Revised Index
Erratum	9 February 2001	p. 46, 4.3.2 a) i)	
Amendment 5 incorporating Erratum	1 July 2001	p. 2, Document Status p. 3, Document History p. 7, References	p. 41, 1.7.2 Comment p. 49, 2.2.4 p. 48, 1.9.1 b) i)
Amendment 6	1 March 2005	p. 11, References	
Amendment 7	1 April 2007	pp. 11–12, 14, References pp. 15–16, Definitions	p. 18, 6.1

B1: Document History			
Amendment 8	1 December 2008	p. 2, Document Status p. 3, Document History p. 9, Contents pp. 11–14, References pp. 15–16, Definitions	pp. 17–22B, B1/VM1 p. 51, B1/VM4 1.0.5, 2.0.1 p. 56, B1/VM4 Figure 2 p. 70, B1/VM4 B1.0.2 pp. 83–84, 86 Index
Amendment 9	30 September 2010	pp. 2–3, Document History, Status, pp. 11–14, References p. 20, B1/VM1 2.2.13 p. 21, B1/VM1 3.0, 5.1 pp. 22–22B, B1/VM1 11.0 pp. 23–24, B1/AS1 6.0, 6.1, 6.2, 6.3, 6.4, 7.1, 7.2, 7.3, 7.4	p. 27, B1/AS2 1.0.5 p. 44, B1/AS3 1.7.9 p. 47, B1/AS3 1.8.5, 1.8.6 p. 49, B1/AS3 2.1.1, 2.2.4 p. 63, B1/VM4 4.3.2 p. 67, B1/VM4 5.3.1
Reprinted incorporating Amendments 4–9	30 September 2010		
Erratum 1	30 September 2010	p. 21, B1/VM1 3.1	
Amendment 10 (Canterbury)	Effective from 19 May 2011 until 31 January 2012	p. 9, Contents p. 12–14, References p. 15, Definitions p. 17, B1/VM1	p. 20, B1/VM1 2.2.14A to 2.2.14D pp. 23–23C B1/AS1 1.4, 2.0, 3.0, 4.0 p. 48, B1/AS3 1.9.3 p. 84, Index
Amendment 11	Effective from 1 August 2011 until 14 August 2014	p. 9, Contents p. 11–14, References p. 17–22B, B1/VM1 1.0, 2.0, 2.2.9, 2.2.14c, 5.2, 6.1, 7.1, 8.1, 12.1, 13.0	pp. 23–24, B1/AS1 1.2, 2.0, 3.0, 4.0, 7.0, 8.0, 9.0 pp. 27–34, B1/AS2 pp. 83–87, Index
Amendment 12	Effective from 14 February 2014 until 31 May 2016	p. 9, Contents pp. 11–13, References pp. 15, 16, Definitions pp. 17, 18, 20, 22, 22A, 22B, B1/VM1 2.1, 2.2.6, 2.2.11, 5.2, 9.0, 12.1	pp. 23–23C, 24 B1/AS1 1.1, 1.2, 2.1.1–2.1.10, 3.1.9, 4.1.5, 8.0, 9.0 p. 79, B1/VM4 C11.0
Amendment 13	Effective from 1 June 2016 until 30 May 2017	p. 13, References	p. 24, B1/AS1 7.3.3, 7.3.4
Amendment 14	Effective from 4 November 2016 until 30 May 2017 Effective from 1 January 2017 until 30 May 2017	p. 9 Contents p.p. 14 References p. 22 B1/VM1 3.1 d) p. 22C VM1 14.1.1	pp. 22C–22F B1/VM1 14.1, 14.1.2 - 14.1.22 pp. 23, 23B B1/AS1 2.1.3, 3.1.8 pp. 84, 87 Index
Amendment 15	Effective from 1 January 2017 until 30 June 2018	p. 13 References p. 20 B1/VM1 2.2.14A, 2.2.14B p. 21 B1/VM1 3.1 p. 22B 13.1 p. 23A B1/AS1 3.1.2A, 3.1.2B, 3.1.2C	p. 24 B1/AS1 7.0 p. 37 B1/AS3 Scope p. 41 B1/AS3 1.7.2 p. 49 B1/AS3 2.2.4 p. 54 B1/VM4 3.3.2
Amendment 16	Effective 3 April 2018 until 31 March 2019	p. 9 Contents pp. 11–14A References p. 18 B1/VM1 2.2.5	pp. 21–22 B1/VM1 3.1, 5.1 p. 57 B1/VM4 3.3.2 p. 65 B1/VM4 4.3.4
Amendment 17	Effective from 30 November 2018 until 31 October 2019	p. 11–13 References p. 17 B1/VM1 2.1	p. 22 B1/VM1 5.1.4A, 5.1.9A p. 84 Index
Amendment 18	Effective from 27 June 2019 until 31 March 2020 except for Definition of Good ground in B1/AS1 (effective until 29 November 2021)	p. 9 Contents pp. 12, 14A References pp. 21, 22A B1/VM1 3.1.1, 3.1.2, 5.3	pp. 23, 24 B1/AS1 1.1, 9.0 p. 84 Index
Amendment 19	Effective on 28 November 2019 until 2 November 2022	p. 9 Contents pp. 11–14A References p. 15 Definitions p. 21 B1/VM1 5.1.1	pp. 23–23H B1/AS1 1.2, 2.1.2, 3.1.1 3.1.8, 3.1.14, 3.2, 4.1.5, 6.1, 6.2
Amendment 20	Effective on 29 November 2021	pp. 12, 14–14A References p. 21 B1/VM1 3.1.0, 4.1.0 p. 22B B1/VM1 11.1 pp. 22C–22F B1/VM1 14.1.1–14.1.22	p. 23 B1/AS1 2.1.0, 2.1.2 p. 23A B1/AS1 3.1.0 p. 23D B1/AS1 7.5.2, 4.4 Comment

New Zealand Building Code

Clause B1 Structure

This Clause is extracted from the New Zealand Building Code contained in the First Schedule of the Building Regulations 1992.

16	<i>Building Regulations 1992</i>	1992/150
FIRST SCHEDULE— <i>continued</i>		
Clause B1—STRUCTURE		
Provisions	Limits on application	
OBJECTIVE		
B1.1 The objective of this provision is to:		
<ul style="list-style-type: none"> (a) Safeguard people from injury caused by structural failure, (b) Safeguard people from loss of <i>amenity</i> caused by structural behaviour, and (c) Protect <i>other property</i> from physical damage caused by structural failure. 		
FUNCTIONAL REQUIREMENT		
B1.2 <i>Buildings, building elements and sitework</i> shall withstand the combination of loads that they are likely to experience during <i>construction or alteration</i> and throughout their lives.		
PERFORMANCE		
B1.3.1 <i>Buildings, building elements and sitework</i> shall have a low probability of rupturing, becoming unstable, losing equilibrium, or collapsing during <i>construction or alteration</i> and throughout their lives.		
B1.3.2 <i>Buildings, building elements and sitework</i> shall have a low probability of causing loss of <i>amenity</i> through undue deformation, vibratory response, degradation, or other physical characteristics throughout their lives, or during <i>construction or alteration</i> when the <i>building</i> is in use.		
B1.3.3 Account shall be taken of all physical conditions likely to affect the stability of <i>buildings, building elements and sitework</i> , including:		
<ul style="list-style-type: none"> (a) Self-weight, (b) Imposed gravity loads arising from use, (c) Temperature, 		

FIRST SCHEDULE—*continued*

Provisions	Limits on application
<ul style="list-style-type: none"> (d) Earth pressure, (e) Water and other liquids, (f) Earthquake, (g) Snow, (h) Wind, (i) <i>Fire</i>, (j) Impact, (k) Explosion, (l) Reversing or fluctuating effects, (m) Differential movement, (n) Vegetation, (o) Adverse effects due to insufficient separation from other <i>buildings</i>, (p) Influence of equipment, services, non-structural elements and contents, (q) Time dependent effects including creep and shrinkage, and (r) Removal of support. <p>B1.3.4 Due allowance shall be made for:</p> <ul style="list-style-type: none"> (a) The consequences of failure, (b) The intended use of the <i>building</i>, (c) Effects of uncertainties resulting from <i>construction</i> activities, or the sequence in which <i>construction</i> activities occur, (d) Variation in the properties of materials and the characteristics of the site, and (e) Accuracy limitations inherent in the methods used to predict the stability of <i>buildings</i>. <p>B1.3.5 The demolition of <i>buildings</i> shall be carried out in a way that avoids the likelihood of premature collapse.</p> <p>B1.3.6 <i>Sitework</i>, where necessary, shall be carried out to:</p>	

18

Building Regulations 1992

1992/150

FIRST SCHEDULE—*continued*

Provisions	Limits on application
(a) Provide stability for <i>construction</i> on the site, and (b) Avoid the likelihood of damage to <i>other property</i> .	
B1.3.7 Any <i>sitework</i> and associated supports shall take account of the effects of:	
(a) Changes in ground water level, (b) Water, weather and vegetation, and (c) Ground loss and slumping.	

ARCHIVED

Contents

ARCHIVED

	Page		Page
References	11	Acceptable Solution B1/AS1	23
Definitions	15	General	23
Verification Method B1/VM1	17	1.0 Explanatory Note	23
		2.0 Masonry	23
			Page
Amend 4 Dec 2000		General	23
		2.1 NZS 4229	23
Amend 8 and 16		1.0 General	17
		2.0 Structural Design Actions Standards	17
		3.0 Timber	23A
		3.1 NZS 3604	23A
		3.2 Slab-on-ground in expansive soils	23C
Amend 3 Dec 1995		3.0 Concrete	21
		3.1 NZS 3101: Part 1	21
		4.0 Concrete Masonry	21
		4.1 NZS 4230	21
		5.0 Steel	21
		5.1 NZS 3404: Part 1	21
Amend 10 May 2011		5.2 AS/NZS 4600	22A
Amends 11 and 18		6.0 Timber	22A
		6.1 NZS 3603	22A
		7.0 Aluminium	22A
		7.1 AS/NZS 1664.1	22A
		8.0 Earth Buildings	22B
		8.1 NZS 4297	22B
		9.0 Foundations	22B
		10.0 Siteworks	22B
		10.1 NZS 4431	22B
Amend 10 May 2011		11.0 Drains	22B
Amend 20 Nov 2021		11.1 NZS/AS 3725	22B
		12.0 Windows	22C
		12.1 NZS 4211	22C
		13.0 Seismic Performance of Engineering Systems in Buildings	22C
Amend 20 Nov 2021		13.1 NZS 4219	22C
		14.0 Ductile Steel Mesh	22C
Amend 20 Nov 2021		14.1 Grade 500E welded steel mesh	22C
		3.0 Timber	23A
		3.1 NZS 3604	23A
		3.2 Slab-on-ground in expansive soils	23C
		4.0 Earth Buildings	23G
		4.1 NZS 4299	23G
		5.0 Stucco	23G
		5.1 NZS 4251	23G
		6.0 Drains	23H
		6.1 AS/NZS 2566.1	23H
		6.2 AS/NZS 2566.2	23H
		6.3 AS/NZS 2032	23H
		6.4 AS/NZS 2033	23H
		7.0 Glazing	24
		7.1 NZS 4223	24
		8.0 Small Chimneys	24
		9.0 Steel	24
		9.1 NASH Standard Part 2 Light Steel Framed Buildings	24
		Verification Method B1/VM2 Timber Barriers	25
		Acceptable Solution B1/AS2 Timber Barriers	27
		Verification Method B1/VM3 Small Chimneys	35
		Acceptable Solution B1/AS3 Small Chimneys	37

Amend 20
Nov 2021
Amend 20
Nov 2021

Amend 20
Nov 2021

Amend 20
Nov 2021

Amend 19
Nov 2019

Amend 4
Dec 2000

Amend 12
Feb 2014

Amends
11 and 18

Amend 11
Aug 2011

ARCHIVED

Scope	37	5.0 Pile Types	66
1.0 Chimney Construction	37	5.1 Concrete piles	66
1.1 General	37	5.2 Steel piles	67
1.2 Chimney wall thickness	37	5.3 Timber piles	67
1.3 Foundations	37	Appendix A (Informative)	69
1.4 Hearths	41	A1.0 Site Investigations	69
1.5 Chimney breasts	41	Appendix B (Informative)	70
1.6 Reinforcing	41	B1.0 Serviceability Limit State Deformations (Settlement)	70
1.7 Chimney restraint	41	Appendix C (Informative)	71
1.8 Materials and construction	47	C1.0 Description of Wall, Limit States, and Soil Properties	71
1.9 Systems to resist horizontal earthquake loadings	47	C2.0 Earth Pressure Coefficients	72
2.0 Solid Fuel Burning Domestic Appliances	49	C3.0 Load Factors and Strength Reduction Factors	72
2.1 Chimneys	49	C4.0 Notation	72
2.2 Hearth slab	49	C5.0 Loadings	73
Verification Method B1/VM4 Foundations	51	C6.0 Surcharge Pressures at Toe	75
1.0 Scope and limitations	51	C7.0 First Ultimate Limit State (short term static foundation bearing failure)	76
2.0 General	51	C8.0 Second Ultimate Limit State (short term static foundation sliding failure)	77
3.0 Shallow Foundations	52	C9.0 Third Ultimate Limit State (short term foundation bearing failure under EQ)	77
3.1 General provisions	52	C10.0 Fourth Ultimate Limit State (short term foundation sliding failure under EQ)	78
3.2 Ultimate and design bearing strength and design bearing pressure	52	C11.0 Fifth Ultimate Limit State (long term foundation bearing failure)	78
3.3 Ultimate limit state bearing strength for shallow foundations	52	C12.0 Sixth Ultimate Limit State (long term foundation sliding failure)	79
3.4 Ultimate limit state sliding resistance	58	C13.0 Comments	80
3.5 Strength reduction factors	59	Acceptable Solution B1/AS4 Foundations	81
4.0 Pile Foundations	59	(Revised by Amendment 4)	
4.1 Ultimate vertical strength of single piles	60	Index	83
4.2 Column action	61	(Revised by Amendment 4)	
4.3 Ultimate lateral strength of single piles	63		
4.4 Pile groups	66		
4.5 Downdrag	66		
4.6 Ultimate lateral strength of pile groups	66		
4.7 Strength reduction factors	66		

Amend 4
Dec 2000

Amend 4
Dec 2000

Amend 4
Dec 2000

Amend 4
Dec 2000

Amend 11
Aug 2011

References

For the purposes of New Zealand Building Code compliance, the acceptable New Zealand and other Standards, and other documents referred to in these Verification Methods and Acceptable Solutions (primary reference documents) shall be the editions, along with their specific amendments, listed below. Where the primary reference documents refer to other Standards or other documents (secondary reference documents), which in turn may also refer to other Standards or other documents, and so on (lower order reference documents), then the applicable version of these secondary and lower order reference documents shall be the version in effect at the date these Verification Methods and Acceptable Solutions were published.

Amend 12
Feb 2014

Amend 7
Apr 2007

Amend 12
Feb 2014

Standards New Zealand

Where quoted

Amend 16 Apr 2018 Amend 19 Nov 2019	AS/NZS 1163: 2016 Cold-formed structural steel hollow sections <i>Amend: 1</i>	VM1 5.1.1
Amend 11 Aug 2011	AS/NZS 1170: Structural design actions – Part 0: 2002 General principles <i>Amends: 1, 2, 3, 4, 5</i>	VM1 1.0, 2.1, 2.2, 5.2, 6.1, 7.1, 8.1 AS1 7.2, 7.3 VM4 2.0, B1.0
Amend 12 Feb 2014	Part 1: 2002 Permanent imposed and other actions <i>Amends: 1, 2</i>	
Amends 12 and 17	Part 2: 2011 Wind actions <i>Amends: 1, 2, 3, 4, 5</i>	
	Part 3: 2003 Snow and ice actions <i>Amend: 1</i>	
Amends 10 and 11	NZS 1170: Structural design actions – Part 5: 2004 Earthquake actions – New Zealand	VM1 2.1, 2.2
Amend 11 Aug 2011	COMMENT The above suite of Structural Design Action Standards, together with their amendments, are referred to collectively as “AS/NZS 1170.”	
Amend 8 Dec 2008	AS/NZS 1554: Structural steel welding Part 1: 2014 Welding of steel structures <i>Amends: 1, 2</i>	VM1 5.1.13
Amend 16 Apr 2018	AS/NZS 1594: 2002 Hot-rolled steel flat products	VM1 5.1.1
	AS/NZS 1664: Aluminium structures – Part 1: 1997 Limit state design <i>Amend: 1</i>	VM1 7.1
Amends 8 and 9		
Amend 7 Apr 2007	AS/NZS 1748:- Timber – Stress graded for structural purposes Part 1: 2011 General requirements <i>Amend: 1</i>	VM1 6.1 VM1 6.1
Amend 12 Feb 2014	Part 2: 2011 Qualification of grading method <i>Amend: 1</i>	VM1 6.1
Amend 9 Sep 2010	AS/NZS 2032: 2006 Installation of PVC pipe systems <i>Amend: 1</i>	AS1 6.3

		Where quoted	
Amend 9 Sep 2010	AS/NZS 2033: 2008 Installation of polyethylene pipe systems <i>Amends 1, 2</i>	AS1 6.4	
Amend 17 Nov 2018 Amend 20 Nov 2021 Amend 9 Sep 2010	AS/NZS 2327: 2017 Composite structures – Composite steel-concrete construction in buildings <i>Amend: 1</i>	VM1 5.1.4A	
Amend 19 Nov 2019	AS/NZS 2566: 2002 Buried Flexible pipelines. Part 1: 1998 Structural Design <i>Amend: 1</i>	AS1 6.1	
Amend 19 Nov 2019	Part 2: 2002 Installation <i>Amends: 1, 2, 3</i>	AS1 6.2	
	AS/NZS 2918: 2001 Domestic solid fuel heating appliances installation	AS3 3.2.1, 2.2.4	
Amend 16 Apr 2018	NZS 3101:- Concrete structures standard Part 1: 2006 The design of concrete structures <i>Amends: 1, 2, 3</i>	VM1 3.1, 11.1	Amend 18 Jun 2019
Amend 6 Mar 2005			
Amend 8 Dec 2008	NZS 3106: 2009 Design of concrete structures for the storage of liquids.	VM1 3.2	
Amend 9 Sep 2010			
Amend 7 Apr 2007	NZS 3109: 1997 Concrete construction <i>Amend: 1, 2</i>	AS3 1.8.2, 1.8.5 b), 2.2.1 c), 2.2.3	
Amend 9 Sep 2010	NZS 3112:- Methods of test for concrete Part 2: 1986 Tests relating to the determination of strength of concrete <i>Amend: 1, 2</i>	AS3 1.8.3 c)	
Amend 9 Sep 2010			
Amend 9 Sep 2010	NZS 3404:- Steel structures standard Part 1: 1997 Steel structures standard <i>Amend: 1, 2</i>	VM1 5.1	
Amend 9 Sep 2010	SNZ TS 3404: 2018 Durability requirements for steel structures and components	VM1 5.1.9A	
Amend 17 Nov 2018			
Amend 9 Sep 2010			
Amend 11 Aug 2011	NZS 3603: 1993 Timber structures standard <i>Amend: 1, 2</i> (Applies to building work consented prior to 1 April 2007) <i>Amend: 1, 2, 4</i> (Applies to building work consented on or after 1 April 2007)	VM1 6.1, VM4 5.3.1	
Amend 7 Apr 2007			
Amend 10 May 2011	NZS 3604: 2011 Timber framed buildings	AS1 1.4, 3.1, 3.2, 4.1 AS3 1.1.1, 1.9.1 b), 1.9.2, 1.9.5, 2.2.1 b),	Amend 19 Nov 2019
Amend 11 Aug 2011			
Amend 9 Sep 2010	NZS 3605: 2001 Timber piles and poles for use in building	VM4 5.3.1	

ARCHIVED

		Where quoted	
Amend 7 Apr 2007	NZS 3622: 2004	Verification of timber properties <i>Amend: 1</i>	VM1 6.1
Amend 11 Aug 2011			
Amends 9 and 12	NZS 3640: 2003	Chemical preservation of round and sawn timber <i>Amends: 1, 2, 3, 4, 5</i>	VM4 5.3.1
	AS/NZS 3678: 2016	Structural steel – Hot-rolled plates, floorplates and slabs	VM1 5.1.9
Amend 16 Apr 2018	AS/NZS 3679 Part 1: 2016 Part 2: 2016	Structural steel Hot-rolled bars and sections Welded I sections	VM1 5.1.9 VM1 5.1.9
	AS/NZS 3725: 2007	Design for installation of buried concrete pipes	VM1 11.1
Amend 8 Dec 2008			
Amend 9 Sep 2010	AS/NZS 3869: 1999	Domestic solid fuel burning appliances – Design and construction	AS3 2.1
	AS/NZS 4058: 2007	Pre cast concrete pipes (pressure and non-pressure)	VM1 11.1
Amends 10 and 11	NZS 4210: 2001	Code of practice for masonry construction: materials and workmanship <i>Amend: 1</i>	AS3 1.8.1, 1.8.3 (f and g)
Amend 9 Sep 2010			
Amend 11 Aug 2011	NZS 4211: 2008	Specification for performance of windows <i>Amend: 1</i>	VM1 12.1
Amend 17 Nov 2018			
Amend 8 Dec 2008			
Amend 11 Aug 2011	NZS 4219 : 2009	Seismic Performance of Engineering Systems in Buildings	VM1 1.3.1
Amend 9 Sep 2010	NZS 4223:- Part 1: 2008	Glazing in buildings Glass selection and glazing <i>Amend 1</i>	AS1 7.1, 7.2.1, 7.3.7
Amend 9 Sep 2010 Amend 15 Jan 2017	Part 2: 2016	Insulating glass units	AS1 7.2
Amends 13 & 15 Amend 15 Jan 2017	Part 3: 2016	Human impact safety requirements <i>Amend: 1</i>	AS1 7.3
Amend 9 Sep 2010 Amend 15 Jan 2017	Part 4: 2008	Wind, dead, snow, and live actions <i>Amend 1</i>	AS1 7.4
Amends 10 and 11	NZS 4229: 2013	Concrete masonry buildings not requiring specific engineering design	AS1 1.4, 2.1 AS3 1.1.1, 1.8.4, 1.9.2, 1.9.5, 2.2.1 b)
Amend 12 Feb 2014			
Amend 8 Dec 2008	NZS 4230: 2004	Design of reinforced concrete masonry structures <i>Amend: 1</i>	VM1 4.0
Amend 11 Aug 2011	NZS 4251:- Part 1: 2007	Solid plastering Cement plasters for walls, ceilings and soffits	AS1 5.1

ARCHIVED

		Where quoted
	NZS 4297: 1998 Engineering design of earth buildings	VM1 8.1
Amends 10 and 11	NZS 4299: 1998 Earth buildings not requiring specific design <i>Amend: 1</i>	AS1 1.4, 4.1
	NZS 4402:- Methods of testing soils for civil engineering purposes.	VM1 11.1
	Test 2.2: 1986 Soil classification tests – Determination of liquid limit	Definitions
	Test 2.4: 1986 Soil classification tests – Determination of plasticity index	VM1 11.1
	Test 2.6: 1986 Soil classification tests – Determination of the linear shrinkage	Definitions
	Test 2.8.1: 1986 Soil classification tests – Standard method by wet sieving	VM1 11.1
	Test 2.8.2: 1986 Soil classification tests – Standard method by dry sieving	VM1 11.1
	Test 2.8.3: 1986 Soil classification tests – Standard method for fine soils (pipette method)	VM1 11.1
	Test 2.8.4: 1986 Soil classification tests – Subsidiary method for fine soils (hydrometer method)	VM1 11.1
	Test 4.1.1: 1986 Soil compaction tests – Determination of the dry density/water content relationship – New Zealand standard compaction test	VM1 11.1
	Test 4.2.1: 1988 Soil compaction tests – Determination of the minimum and maximum dry densities and relative density of a cohesionless soil – Minimum dry density	VM1 11.1
	Test 4.2.2: 1988 Soil compaction tests – Determination of the minimum and maximum dry densities and relative density of a cohesionless soil – Maximum dry density	VM1 11.1
	Test 4.2.3: 1988 Soil compaction tests – Determination of the minimum and maximum dry densities and relative density of a cohesionless soil – Relative density	VM1 11.1, VM4 4.1.1
Amend 16 Apr 2018	Test 5.1.1: 1986 Soil density tests – Determination of the density of soil – Sand replacement test for the determination of in situ density	VM1 11.1
	NZS 4431: 1989 Code of practice for earth fill for residential development <i>Amend: 1</i>	VM1 10.1
Amend 19 Nov 2019 Amend 20 Nov 2021	AS/NZS 4600: 2005 Cold-formed steel structures <i>Amend: 1</i>	VM1 5.2
Amends 10 and 11	AS/NZS 4671: 2019 Steel for the reinforcement of concrete	AS1 2.1.5, 3.1.8 AS3 1.8.5, VM1 14.0
Amend 9 Sep 2010	AS/NZS 4680: 2006 Hot-Dip Galvanised (zinc) Coating	AS3 1.8.6
Amend 16 Apr 2018 Amend 20 Nov 2021	AS/NZS 5131: 2016 Structural steelwork – Fabrication and erection <i>Amend: 1</i>	VM1 5.1.3, 5.1.5-5.1.8, 5.1.10-5.1.12

Amend 14
Nov 2016

ARCHIVED

Amend 8 Dec 2008	SNZ HB 8630: 2004 Tracks and outdoor visitor structures	Where quoted VM1 2.2.9
The National Association of Steel Framed Housing Inc (NASH)		
Amend 11 Aug 2011	NASH Standard Part 2: May 2019 Light Steel Framed Buildings	AS1 9.1
Amend 18 Jun 2019		
British Standards Institution		
	BS 8004: 1986 Code of practice for foundations	VM4 4.0.3
	BS EN 14399 High-strength structural bolting assemblies for preloading	
	Part 1: 2015 General requirements	VM1 5.1.4
	Part 2: 2015 Suitability for preloading	VM1 5.1.4
	Part 3: 2015 System HR. Hexagon bolt and nut assemblies	VM1 5.1.2, 5.1.4
Amend 16 Apr 2018	Part 5: 2015 Plain washers	VM1 5.1.2, 5.1.4
Standards Australia		
Amend 14 Nov 2016	AS 1391: 2007 Metallic materials – Tensile testing at ambient temperature	VM1 14.1.1
Amends 9 and 19	AS 1397: 2011 Steel sheet and strip – Hot-dipped zinc-coated or aluminium/zinc-coated	AS3 1.7.9
Amend 11 Aug 2011	AS 2159: 1995 Rules for the design and installation of piling (known as the SAA Piling Code) <i>Amend: 1</i>	VM4 4.0.3
American Society of Testing and Materials		
	ASTM D1143: 1981 Test method for piles under static axial compressive load	VM4 4.0.3
New Zealand Geotechnical Society Inc.		
Amend 20 Nov 2021	Field Description of Soil and Rock – Guidelines for the field descriptions of soils and rocks for engineering purposes. December 2005	VM1 11.1
New Zealand Legislation		
Amend 8 Dec 2008	Chartered Professional Engineers of New Zealand Act 2002	VM1 1.0
International Organization for Standardization		
	ISO 15630-2 2010: Steel for the reinforcement and prestressing of concrete – Test Methods – Part 2 Welded Fabric	VM1 14.1.1
Amend 14 Nov 2016	ISO 17025: 2005 General requirements for the competence of testing and calibration laboratories	VM1 14.1.1

ARCHIVED

Definitions

ARCHIVED

This is an abbreviated list of definitions for words or terms particularly relevant to these Acceptable Solutions and Verification Methods. The definitions for any other italicised words may be found in the New Zealand Building Code Handbook.

Amends
7 and 12

Amend 8
Dec 2008

Adequate *Adequate* to achieve the objectives of the *Building Code*.

Alter in relation to a *building*, includes to rebuild, re-erect, repair, enlarge and extend the *building*.

Baluster A post providing the support for the top and bottom rails of a barrier.

Boundary joist A joist running along the outer ends of the floor joists.

Amend 7
Apr 2007

Building has the meaning ascribed to it by sections 8 and 9 of the Building Act 2004.

Building element Any structural and non-structural component or assembly incorporated into or associated with a *building*. Included are *fixtures*, *services*, *drains*, permanent mechanical installations for access, glazing, partitions, ceilings and temporary supports.

Amend 10
May 2011

Canterbury earthquake region is the area contained within the boundaries of the Christchurch City Council, the Selwyn District Council and the Waimakariri District Council.

Chimney A *non-combustible* structure which encloses one or more *flues*, *fireplaces* or other heating appliances.

Chimney back The *non-combustible* wall forming the back of a *fireplace*.

Chimney base That part of a *chimney* which houses the *fireplace*.

Chimney jambs The side walls of a *fireplace*.

Combustible See *non-combustible*.

Amend 8
Dec 2008

Construct in relation to a *building*, includes to design, build, erect, prefabricate, and relocate the *building*.

Drain A pipe normally laid below ground level including fittings and equipment and intended to convey *foul water* or *surface water* to an *outfall*.

Factor of safety in relation to any *building* means the ratio of resisting forces to applied forces for a given loading condition. It is generally expressed to two significant figures.

Fireplace A space formed by the *chimney back*, the *chimney jambs*, and the *chimney breast* in which fuel is burned for the purpose of heating the room into which it opens.

Fixture An article intended to remain permanently attached to and form part of a *building*.

Flue The passage through which the products of combustion are conveyed to the outside.

Gather That part of a *chimney* where the transition from *fireplace* to stack occurs.

Good ground means any soil or rock capable of permanently withstanding an ultimate bearing pressure of 300 kPa (i.e. an allowable bearing pressure of 100 kPa using a factor of safety of 3.0), but excludes:

- a) Potentially compressible ground such as topsoil, soft soils such as clay which can be moulded easily in the fingers, and uncompacted loose gravel which contains obvious voids,
- b) Expansive soils being those that have a liquid limit of more than 50% when tested in accordance with NZS 4402 Test 2.2, and a linear shrinkage of more than 15% when tested, from the liquid limit, in accordance with NZS 4402 Test 2.6, and
- c) Any ground which could foreseeably experience movement of 25 mm or greater for any reason including one or a combination of: land instability, ground creep, subsidence, liquefaction, lateral spread, seasonal swelling and shrinking, frost heave, changing ground water level, erosion, dissolution of soil in water, and effects of tree roots.

Amend 4
Dec 2000

Amends
10 and 19

ARCHIVED

COMMENT:

Soils (excepting those described in a), b) and c) above) tested with a dynamic cone penetrometer in accordance with NZS 4402 Test 6.5.2, shall be acceptable as good ground for *building* foundations if penetration resistance is no less than:

- a) 5 blows per 100 mm at depths down to twice the footing width.
- b) 3 blows per 100 mm at depths greater than twice the footing width.

Depths shall be measured from the underside of the proposed footing.

Hearth The insulating floor under the *fire* and in front and at the sides of the *fireplace*.

Intended use, in relation to a *building*:

- a) includes any or all of the following:
 - i) any reasonably foreseeable occasional use that is not incompatible with the *intended use*;
 - ii) normal maintenance;
 - iii) activities undertaken in response to *fire* or any other reasonably foreseeable emergency; but
- b) does not include any other maintenance and repairs or rebuilding.

Nominal pile width The least width of a pile in side view and is equal to the diameter in round piles.

Non-combustible Materials shall be classified as *non-combustible* or *combustible* when tested to: AS 1530 – Part 1.

Other property

- a) means any land or *buildings*, or part of any land or *buildings*, that are—
 - i) not held under the same *allotment*; or
 - ii) not held under the same ownership; and
- b) includes a road

Sitework means work on a *building* site, including earthworks, preparatory to or associated with the *construction*, *alteration*, demolition or removal of a *building*.

Specified intended life has the meaning given to it by section 113(3) of the Building Act 2004.

Section 113(3) states:

“(3) In subsection (2), **specified intended life**, in relation to a building, means the period of time, as stated in an application for a building consent or in the consent itself, for which the building is proposed to be used for its intended use.”

Strength reduction factor The factor by which the ultimate strength is multiplied to obtain the design strength.

COMMENT:

NZS 4203: 1992 uses the terms ideal strength in place of ultimate strength, and dependable strength in place of design strength.

Surface water All naturally occurring water, other than sub-surface water, which results from rainfall on the site or water flowing onto the site, including that flowing from a *drain*, stream, river, lake or sea.

Territorial authority (TA) means a city council or district council named in Part 2 of Schedule 2 of the Local Government Act 2002; and—

- a) in relation to land within the district of a *territorial authority*, or a *building* on or proposed to be built on any such land, means that *territorial authority*; and
- b) in relation to any part of a coastal marine area (within the meaning of the Resource Management Act 1991) that is not within the district of a *territorial authority*, or a *building* on or proposed to be built on any such part, means the *territorial authority* whose district is adjacent to that part.

Verification Method means a method by which compliance with the *Building Code* may be verified.

Amend 12
Feb 2014

Amend 4
Dec 2000

Amend 7
Apr 2007

Amend 7
Apr 2007

Amend 8
Dec 2008

Amend 8
Dec 2008

Amend 2
Aug 1994

Amend 8
Dec 2008

Verification Method B1/VM1 General

ARCHIVED

Amend 10
May 2011

Amend 8
Dec 2008

1.0 General

1.0.1 The Standards cited in this *Verification Method* provide a means for the design of structures to meet the performance requirements of New Zealand Building Code Clause B1 Structure. For any particular *building* or *building* design, the *Verification Method* shall consist of AS/NZS 1170 used in conjunction with the relevant cited material standards as modified by this *Verification Method*.

1.0.2 Modifications to the Standards, necessary for compliance with the New Zealand *Building Code*, are given against the relevant clause number of each Standard.

1.0.3 Citation of Standards in this *Verification Method* is subject to the following conditions.

- a) The citation covers only the scope stated or implicit in each Standard. Aspects outside the scope, when applied to a particular *building*, are not part of the *Verification Method*.
- b) Further limitations, modifications and/or constraints apply to each Standard as noted below.
- c) Provisions in the cited Standards that are in non-specific or unquantified terms do not form part of the *Verification Method*. Non-specific or unquantified terms include, but are not limited to, special studies, manufacturer's advice and references to methods that are appropriate, adequate, suitable, relevant, satisfactory, acceptable, applicable, or the like.
- d) Where AS/NZS 1170 is used in combination with other Standards cited in this *Verification Method* and there are incompatibilities with these other Standards, then the underlying philosophy, general approach, currency of information and methods of AS/NZS 1170 are to take precedence.

Amend 11
Aug 2011

Amend 11
Aug 2011

Amend 11
Aug 2011

- e) An engineer with relevant experience and skills in structural engineering shall be responsible for interpretation of the requirements of the Standards cited when used for *building* structure design. A structural engineer who is chartered under the Chartered Professional Engineers of New Zealand Act 2002 would satisfy this requirement.

COMMENT

The Standards referenced in this *Verification Method* relating to *building* design require the application of specialist engineering knowledge, experience and judgement in their use.

2.0 Structural Design Actions Standards

2.1 The requirements of the AS/NZS 1170 suite of Standards are to be complied with. These comprise:

AS/NZS 1170.0: 2002 including Amendments 1, 2, 3, 4 and 5

AS/NZS 1170.1: 2002 including Amendments 1 and 2

AS/NZS 1170.2: 2011 including Amendments 1, 2, 3, 4 and 5

AS/NZS 1170.3: 2003 including Amendment 1, and NZS 1170.5: 2004.

COMMENT

This suite of Standards, together with their amendments, are referred to collectively in this *Verification Method* as "AS/NZS 1170".

2.2 The requirements of AS/NZS 1170 are subject to the following modifications.

2.2.1 Material Standards Where AS/NZS 1170 calls for the use of appropriate material Standards, only those material Standards referenced in this *Verification Method* B1/VM1 are included. Use of other Standards with AS/NZS 1170 must be treated as an alternative means of verification.

Amend 8
Dec 2008

Amend 12
Feb 2014

Amend 17
Nov 2018

Amend 11
Aug 2011

Amend 11
Aug 2011

Amend 11
Aug 2011

ARCHIVED

2.2.2 Notes in AS/NZS 1170 “Notes” that relate to clauses, tables or figures of AS/NZS 1170 are part of the *Verification Method*.

COMMENT

AS/NZS 1170 makes a general statement that notes are not an integral part of the Standard. However, in many cases the content of the notes makes them an integral part of the interpretation of the Standard. In these cases, the notes have been specifically cited as being part of this *Verification Method*.

2.2.3 AS/NZS 1170 Part 0, Clause 4.1

General Add the following to the end of the Clause:

“The combination factors for permanent actions (dead loads) are based on the assumption that they have a coefficient of variation of approximately 10%. Situations where this assumption is not valid are outside the scope of this *Verification Method*.”

2.2.4 AS/NZS 1170 Part 0, Clause 4.2.4

Replace the Clause with the following:

“The combination of actions for checking strength and stability for the ultimate limit state for *fire* shall be as follows:

(a) During the *fire*:

(i) [G , thermal actions arising from *fire*, $\Psi_f Q$]

together with:

(ii) a lateral force of 2.5% of $(G + \Psi_c Q)$ applied as per Clause 6.2.2.

(b) After the *fire* until the *building* is either repaired or demolished:

(i) [G , thermal actions arising from *fire*, $\Psi_f Q$]

together with the more critical of either:

(ii) a lateral force of 2.5% of $(G + \Psi_c Q)$ applied as per Clause 6.2.2.

or

(iii) a uniformly distributed horizontal face load of 0.5 kPa in any direction.

Account shall be taken of the effects of the *fire* on material properties and the geometry of the structure.”

2.2.6 AS/NZS 1170 Part 1, Table 3.2

Replace the entry for “R2, Other roofs (i) Structural elements” with:

“R2 Other roofs (i) Structural elements 0.25 1.1”

Delete Note 2

Delete Note 3

2.2.7 AS/NZS 1170 Part 1, Clause 3.6 Barriers

In the first paragraph, second sentence, delete “... top edge or handrail...” and substitute “... top edge **and rail...**”

Delete the second paragraph and substitute:

“Apply as detailed below the uniformly distributed line loads (kN/m), uniformly distributed loads (kPa) and concentrated loads (kN) given in Table 3.3.

For the purposes of applying loads, a rail shall be any *handrail* or any top rail having a width in plan of greater than 30 mm.

The following are separate load cases, and one load at a time, either vertical or horizontal, is to be applied.

(a) Line loads (kN/m). Regardless of barrier height, line loads need not be applied more than 1200 mm above the floor (or stair pitch line):

(i) For domestic and residential activities, other residential (Row 2 of Table 3.3)

- For barriers with a rail or rails:

- apply the horizontal load to the top rail

Amend 11
Aug 2011

Amend 16
Apr 2018

Amend 12
Feb 2014

Amend 8
Dec 2008

Amend 8
Dec 2008

ARCHIVED

- where the top of the barrier is not a rail and where it is less than 200 mm above the top rail, the horizontal load to the top of the barrier may be reduced by 50%, otherwise apply the full horizontal load
 - apply the vertical load to the top of the barrier.
 - For barriers without a rail, apply:
 - the horizontal load at 900 mm above the floor (or stair pitch line)
 - 50% of the horizontal load to the top of the barrier
 - the vertical load to the top of the barrier.
- (ii) For all types of occupancy other than Row 2 of Table 3.3:
- apply the loads to the top edge of the barrier and to the top rail
 - where the top of the barrier is not a rail and where it is less than 200 mm above the top rail, the horizontal load to the top of the barrier may be reduced by 50%, otherwise apply the full horizontal load.
- (b) Distributed loads (kPa):
- For all types of occupancy:
- consider the load as acting over the whole area bounded by the top of the barrier and the floor line for the full length of the barrier
 - distribute this load to the appropriate solid portions of the barrier.
- (c) Concentrated loads (kN):
- For all types of occupancy:
- consider each concentrated load to be distributed over a circular or square area of 2000 mm²
 - apply concentrated loads so as to produce the most severe effect on the structural element being considered

- concentrated loads applied more than 1200 mm above the floor (or stair pitch line) may be reduced by 50%
- where the barrier infill or *balustrade* consists of parallel vertical members, less than 100 mm wide and with spaces between them of less than 100 mm, 50% of the concentrated load may be applied to each vertical member."

COMMENT

In Table 3.3, "external balconies" for domestic and residential activities applies to decks, balconies, verandahs and the like of individual houses as well as multi household unit buildings. Such barriers may be required by Clause F4 of the *Building Code*.

2.2.8 AS/NZS 1170 Part 1, Clause 3.8

Car park Add to the last paragraph of Clause 3.8:

"The basis for determining the horizontal impact actions on barriers quoted in the Clause, including the assumed deceleration distances, is given in Clause C 3.8 of the Commentary to AS/NZS 1170 Part 1. Different design actions may be derived using Equation C3.8, provided that:

- (i) The deceleration length applied is based on analysis or tests.
- (ii) The vehicle mass and associated velocity are not reduced from those quoted in Commentary Clause C3.8."

2.2.9 AS/NZS 1170 Part 1, Appendix B

Replace the last paragraph with the following:

"For the design of outdoor visitor structures as defined in SNZ HB 8630: 2004, the imposed actions must be as given by that publication with references to NZS 4203 replaced by equivalent references to AS/NZS 1170."

2.2.10 AS/NZS 1170 Part 2, Clauses 3.2

and 4.4.3 Add the following at the end of Clauses 3.2 and 4.4.3:

"Where local wind design information is more onerous than determined by this Standard and is published and required to be used by any *territorial authority* for its area, this local wind design information shall take precedence over the equivalent information in this Standard for the determination of wind actions on *buildings*."

Where such local wind design information is less onerous than that of this Standard, the use of such information is not part of this *Verification Method*."

areas this may involve considerable cost consequences and a reduction in requirements is acceptable when site-specific hazard studies are undertaken."

Consequential changes due to 2010/11 Canterbury earthquakes

COMMENT:

1. As a result of the 2010/11 sequence of earthquakes in Canterbury, there is a heightened risk of seismic activity over the next few decades above that currently factored into structural design requirements. B1/VM1 is amended to reflect an increased seismic hazard factor for the *Canterbury earthquake region*.
2. The seismic hazard factor Z defined in NZS 1170 Part 5 (Table 3.3) has been raised for the *Canterbury earthquake region*. This is reflected in the following amendments to B1/VM1.

2.2.12 AS/NZS 1170 Part 3, Clause 2.1

Add the following at the end of Clause 2.1:

"Where local snow and ice design information is more onerous than determined by this Standard and is published by any *territorial authority* for its area, this local snow and ice design information shall take precedence over the equivalent information in this Standard for the determination of snow and ice actions on *buildings*.

Where such local snow and ice design information is less onerous than that of this Standard, the use of such information is not part of this *Verification Method*."

2.2.14A NZS 1170 Part 5, Clause 3.1.4

Add (to the end of Clause 3.1.4):

"The minimum hazard factor Z (defined in Table 3.3) for the *Canterbury earthquake region* shall be 0.3. Where factors within this region are greater than 0.3 as provided by NZS 1170 Part 5, then the higher value shall apply.

2.2.13 AS/NZS 1170 Part 3, Clause 5.4.3

Add the following to end of Clause 5.4.3:

"For Regions N4 and N5 the minimum value of s_g for the ultimate limit state only must be taken as 0.9 kPa."

2.2.14B NZS 1170 Part 5, Table 3.3

Delete row:	102	Christchurch	0.22	-
Replace with:	102	Christchurch	0.3	-
Delete row:	101	Akaroa	0.16	-
Replace with:	101	Akaroa	0.3	-

2.2.14 NZS 1170 Part 5, Clause 1.4

Add the following to the end of the Clause 1.4:

"Where a special study yields a site-specific uniform risk design spectrum for 500 year return period equivalent to a hazard factor, Z, of less than 0.08, a design spectrum equivalent to at least $Z = 0.10$ may be adopted and the minimum magnitude 6.5 earthquake need not be considered.

COMMENT:

In areas where the uniform risk hazard factor is less than 0.08, the use of a minimum hazard factor $Z = 0.13$ implies design for earthquakes with extremely low probabilities of occurrence. For some projects in these

2.2.14D NZS 1170 Part 5, Figure 3.4

Figure 3.4 Hazard factor Z for the South Island is amended as per Paragraph 2.2.14A above.

Amend 12
Feb 2014

Amend 9
Sep 2010

Amend 8
Dec 2008

Amend 15
Jan 2017

Amend 15
Jan 2017

Amend 11
Aug 2011

Amend 10
May 2011

ARCHIVED

2.2.15 NZS 1170 Part 5, Clause 4.2 Seismic weight and seismic mass After: “0.3 is the earthquake imposed action (live load) combination factor for all other applications” add the following:

“except roofs.

$\psi_E = 0.0$ is the earthquake imposed action (live load) combination factor for roofs.”

2.2.16 NZS 1170 Part 5, Sections 5 and 6 Time history analysis Time history analysis is not part of this *Verification Method*.

COMMENT:

Time history analysis is a highly specialised method of assessing structural response to earthquakes. It requires many detailed and interdependent assumptions to be made in relation to the nature of earthquake shaking and its propagation from the source, the properties of the *building* site and the detailed characteristics of the *building* and its structural elements.

AS/NZS 1170 outlines the steps for time history analysis in some detail, but the applicability of each step needs to be evaluated on a *building-by-building* basis. More importantly, the output of the analysis needs to be examined carefully in each particular context.

Time history analysis can be an acceptable aid to verifying compliance with structural requirements provided that:

- It is carried out by specialists with in-depth experience in applying the technique.
- The output of the analysis and the viability of the resulting structural design are reviewed by an independent team experienced in both analysis and design.

2.2.17 NZS 1170 Part 5, Clause 5.2.2.3, equation 5.2(4) Delete equation 5.2(4) and replace with:

$$C_d(T) = \frac{C(T) S_p}{k_\mu} \quad \dots \text{5.2(4)}$$

2.2.18 NZS 1170 Part 5, Clause 6.1.4.1 Requirement for modelling Delete the last sentence of the first paragraph and replace with:

“The model shall include representation of the diaphragm’s flexibility.”

Delete the third (last) paragraph.

3.0 Concrete

3.1 NZS 3101: Part 1 subject to the following modifications:

3.1.0 Referenced Documents

Replace reference to AS/NZS 4671: 2001, in NZS 3101: Part 1 with the 2019 version that is referenced in this Verification Method.

3.1.1 Clause 18.74.4 Detailing requirements for support of hollow core floors

At the end of Clause 18.74.4 (b) add an additional sentence:

“The details given by C18.6.7(e) may be applied to hollow-core units where the depth of the precast unit is equal to or less than 400 mm.”

COMMENT:

Welded wire fabric that is used in designs to NZS 3101 is subject to the requirements of Paragraph 14.0 Ductile Steel Mesh of this Verification Method.

3.2 NZS 3106

4.0 Concrete Masonry

4.1 NZS 4230 subject to the following modification:

4.1.0 Referenced Documents

Replace reference to AS/NZS 4671: 2001, in NZS 4230 with the 2019 version that is referenced in this Verification Method.

5.0 Steel

5.1 NZS 3404: Part 1 subject to the following modifications:

5.1.1 Clause 2.2.1 Specification

In Clause 2.2.1 a) replace:

“AS 1163 Cold-formed structural steel hollow sections AS 1594 Hot-rolled steel flat products”;

with

“AS/NZS 1163 Cold-formed structural steel hollow sections

AS/NZS 1594 Hot-rolled steel flat products”

5.1.2 Clause 2.3.1 Steel bolts, nuts and washers

In Clause 2.3.1 add the following to the end of the Clause:

“BS EN 14399-3 High-strength structural bolting assemblies for preloading, System

Amend 20 Nov 2021

Amends 9, 14, 15, 16, Err 1

Amend 18 Jun 2019

Amend 16 Apr 2018

Amend 9 Sep 2010

Amend 8 Dec 2008

Amend 20 Apr 2021

Amends 8 and 9

Amend 19 Nov 2019

Amend 16 Apr 2018

Amend 8 Dec 2008

Amend 9 Sep 2010

ARCHIVED

HR. Hexagon bolt and nut assemblies
BS EN 14399-5: High-strength structural bolting assemblies for preloading, Plain washers”

5.1.3 new Clause 3.10 Documentation

Insert the following after clause 3.9:

“Clause 3.10 Documentation
The requirements in AS/NZS 5131 Section 4.1.1 General shall be applied.”

5.1.4 Clause 9.3.1 Bolts and bolting category

In Clause 9.3.1.2 replace:

“and AS 1559”
with
“AS 1559, BS EN 14399.1, BS EN 14399.2, BS EN 14399.3 and BS EN 14399.5.”

5.1.4A Section 13 Design of composite members and structures

Replace Section 13 Design of composite members and structures with the following:
“13 Design of composite members and structures shall be in accordance with AS/NZS 2327.”

5.1.5 Section 14 Fabrication

Replace Section 14 Fabrication with the following:

“14 Fabrication
The fabrication of steel structures shall be in accordance with AS/NZS 5131.
Construction categories for the purposes of this Standard shall be determined in accordance with Appendix C of AS/NZS 5131.”

5.1.6 Section 15 Erection

Replace Section 15 Erection with the following:

“15 Erection
The erection of steel structures shall be in accordance with AS/NZS 5131.
Construction categories for the purposes of this standard shall be determined in accordance with Appendix C of AS/NZS 5131.”

5.1.7 Section 16 Modification of Existing Structures

Replace Section 16 Modification of existing structures with the following:

“16 Site modifications during erection and

modification and repair of existing structures

Site modifications during erection and modification and repair of existing structures shall be in accordance with AS/NZS 5131 Section 14 Site modifications during erection and modification and repair of existing structures.”

5.1.8 new Section 18 Architecturally Exposed Structural Steelwork

Insert the following after Section 17:

“18 Architecturally exposed structural steelwork
The requirements in AS/NZS 5131 Section 10 Architecturally exposed structural steelwork shall be applied.”

5.1.9 Appendix A

Replace references to AS/NZS 3678, AS/NZS 3769.1 and AS/NZS 3679.2 in NZS 3404 with the 2016 versions that are referenced in this Verification Method

5.1.9A Appendix C

Replace Appendix C Corrosion Protection with the following:

“Appendix C Corrosion Protection
Corrosion protection shall be in accordance with SNZTS 3404.”

5.1.10 Appendix D

Replace Appendix D Inspection of Welding to AS/NZS 1554.1 with the following:

“Appendix D Inspection of Welding
The recommendations in AS/NZS 5131 Appendix I Inspection of Welding and Bolting. (Informative) should be used.”

5.1.11 Appendix K

Replace Appendix K Standard test for evaluation of slip factor (normative) with the following:

“Appendix K Standard test for evaluation of slip factor (normative)
The requirements in AS/NZS 5131 Appendix G Standard test for evaluation of slip factor shall be used.”

5.1.12 Appendix L

Replace Appendix L Inspection of bolt tension using a torque wrench (informative) with the following”

Amend 16
Apr 2018

Amend 17
Nov 2018

Amend 16
Apr 2018

Amend 17
Nov 2018

Amend 16
Apr 2018

ARCHIVED

“Appendix L Inspection of bolt tension using a torque wrench (informative)

The recommendations in AS/NZS 5131 Appendix H Inspection of bolt tension using a torque wrench should be used.”

5.1.13 new Appendix R

Insert the following after Appendix Q:

“Appendix R Selection of materials for the avoidance of lamellar tearing (informative)

The guidance in AS/NZS 1554.1 Appendix H Selection of materials for the avoidance of lamellar tearing should be used.”

Amend 16
Apr 2018

5.2 AS/NZS 4600 subject to the following modifications:

- a) Actions must be determined in accordance with AS/NZS 1170. All references to NZS 4203 are replaced by equivalent references to AS/NZS 1170.
- b) The term “normative” identifies a mandatory requirement for compliance with this Standard.
- c) The term “informative” identifies information provided for guidance or background which may be of interest to the Standard’s users. Informative provisions do not form part of the mandatory requirements of the Standard.
- d) Where this Standard has provisions that are in non-specific or unquantified terms then these do not form part of the *Verification Method* and the proposed details must be submitted to the *territorial authority* for approval as part of the *building consent* application. This includes, but is not limited to, special studies and manufacturer’s advice.
- e) All stages of *construction* of a structure or part of a structure to which this Standard is applied shall be adequately reviewed by a person who, on the basis of experience or qualifications, is competent to undertake the review.
- f) The extent of the review to be undertaken shall be nominated by the design engineer, taking into account those materials and workmanship factors which are likely to influence the ability of the finished construction to perform in the predicted manner.

Amends
8 and 11

- g) At the end of the first paragraph of Appendix A add the words “Unless noted otherwise a document referred to below shall be the version of that document current at the date of issue of this Standard or if amendments are cited to this Standard in the “References” pages of this document at the latest date of those amendments.”

Amend 12
Feb 2014

- h) Appendix B shall be read as normative with “shoulds” changed to “shalls”.

Amends
11 and 18

6.0 Timber

6.1 NZS 3603 subject to the following modifications:

- a) Actions must be determined in accordance with AS/NZS 1170. All references to NZS 4203 are replaced by equivalent references to AS/NZS 1170.
- b) Delete Clause 2.2.1.2 and replace with:

“Machine stress-grading shall be in accordance with AS/NZS 1748 as modified by NZS 3622. Machine stress-graded timber shall have its properties verified, and be identified, in accordance with the requirements of NZS 3622.”

Amend 11
Aug 2011

Amend 11
Aug 2011

Amend 7
Apr 2007

Amend 8
Dec 2008

7.0 Aluminium

7.1 AS/NZS 1664.1 subject to the following modifications:

- a) Actions must be determined in accordance with AS/NZS 1170. All references to NZS 4203 are replaced by equivalent references to AS/NZS 1170.
- b) The terms “capacity factor” and “strength limit state” are to be read as “*strength reduction factor*” and “ultimate limit state” respectively.
- c) Where this Standard has provisions that are in non-specific or unquantified terms then these do not form part of the *Verification Method* and the proposed details must be submitted to the *territorial authority* for approval as part of the *building consent* application. This includes, but is not limited to, special studies and manufacturer’s advice.

Amend 11
Aug 2011

Amend 8
Dec 2008

ARCHIVED

d) All stages of *construction* of a structure or part of a structure to which this Standard is applied shall be adequately reviewed by a person who, on the basis of experience or qualifications, is competent to undertake the review.

Amend 8
Dec 2008

e) The extent of the review to be undertaken shall be nominated by the design engineer, taking into account those materials and workmanship factors which are likely to influence the ability of the finished *construction* to perform in the predicted manner.

Amend 8
Dec 2008

f) Clause 1.2 to read "**MATERIALS** This Standard applies to aluminium alloys listed in Table 3.3(A) that comply with AS 1734, AS 1865, AS 1866, AS 1867 and AS 2748.1."

Amend 8
Dec 2008

g) At the end of the first paragraph of Clause 1.4 add the words "Unless noted otherwise a document referred to below shall be the version of that document current at the date of issue of this Standard or if amendments are cited to this Standard in the "References" pages of the Acceptable Solutions and Verification Methods at the latest date of those amendments."

Amend 12
Feb 2014

8.0 Earth Buildings

8.1 NZS 4297 subject to the following modifications:

Actions must be determined in accordance with AS/NZS 1170. All references to NZS 4203 are replaced by equivalent references to AS/NZS 1170.

Amend 11
Aug 2011

9.0 Foundations

See B1/VM4.

Amend 12
Feb 2014

10.0 Siteworks

10.1 NZS 4431

11.0 Drains

11.1 AS/NZS 3725 subject to the following modifications:

Clause 3 Add to the list of reference documents:

"NZS 3101 The design of concrete structures.
NZS 4402 Methods of testing soils for civil engineering purposes: Tests 2.4, 2.8, 4.1.1, 4.2.1, 4.2.2, 4.2.3 and 5.1.1.

New Zealand Geotechnical Society, Field Description of Soil and Rock – Guidelines for the field description of soils and rocks in engineering purposes.

Clause 4 In the paragraph headed "(c) Select fill", after the words "given in Table 1" add "or the New Zealand Geotechnical Society Guidelines.

Clause 5 In definition of Pt, replace "AS 4058" with "AS/NZS 4058"

Clause 6.4 Replace the word "may" with "shall". Delete the words "Superimposed concentrated dead loads should be avoided."

Clause 6.5.3.1 Delete the words "The appropriate road vehicle loading shall be specified by the relevant highway authority or owner".

Clause 6.5.3.2.2.2 Replace the word "may" with "shall".

Clause 6.5.4.3 Delete the words "unless otherwise specified by the Relevant Authority".

Clause 6.5.5 Delete the first words "For" and after the words "for aircraft types" add the words "is outside the scope of this Standard but..."

Clause 7 Replace the word "should" with "shall".

Clause 10.3 After the words "the test load" add "or proof load".

Appendix A Delete "Normative" and replace with "Informative"

Appendix B Delete "Normative" and replace with "Informative"

Amend 20
Nov 2021

Amend 9
Sep 2010

ARCHIVED

12.0 Windows

12.1 NZS 4211 subject to the following modification:

Amend 12
Feb 2014

References to air leakage, water leakage and operational effectiveness of opening sashes in NZS 4211, are non-structural considerations and do not apply to this document.

Amend 18
Jun 2019

Amend 19
Nov 2019
Amend 11
Aug 2011

13.0 Seismic Performance of Engineering Systems in Buildings

13.1 NZS 4219 subject to the following modifications in the *Canterbury earthquake region*:

Amend 11
Aug 2011

The zone factor Z shall be determined from the Standard but shall not be less than 0.3.

14.0 Ductile Steel Mesh

14.1 Grade 500E welded steel mesh

Amend
20 Nov 2021
Amend 14
Nov 2016

Where Grade 500E welded steel mesh is specified, it shall meet the requirements of AS/NZS 4671.

ARCHIVED

Pages 22D – 22F deleted by amendment 20

Acceptable Solution B1/AS1 General

ARCHIVED

1.0 Explanatory Note

Amend 12
Feb 2014

1.1 B1/AS1 contains Acceptable Solutions for Masonry (Paragraph 2.0), Timber (Paragraph 3.0), Earth Buildings (Paragraph 4.0), Stucco (Paragraph 5.0), Drains (Paragraph 6.0), Glazing (Paragraph 7.0) and Steel (Paragraph 9.0).

Amend 18
Jun 2019

Amend 19
Nov 2019
Amend 11
Aug 2011

1.2 B1/AS3 is an Acceptable Solution for small *chimneys* (referred to in Paragraph 8.0).

1.3 Modifications to the Standards, necessary for compliance with the New Zealand Building Code, are given against the relevant clause number of each Standard.

1.4 Consequential changes due to 2010/11 Canterbury earthquakes

COMMENT:

Raising the seismic hazard factor Z in NZS 1170 Part 5 (Table 3.3) for the *Canterbury earthquake region* through amendments to B1/VM1 requires consequential amendments to NZS 4229, NZS 3604 and NZS 4299 referenced in B1/AS1.

Amend 11
Aug 2011

2.0 Masonry

2.1 NZS 4229 subject to the following modifications:

2.1.0 Referenced Documents

Replace reference to AS/NZS 4671: 2001, in NZS 4229 with the 2019 version that is referenced in the Verification Method B1/VM1.

2.1.1 NZS 4229 Clause 7.8.3

Delete clause 7.8.3.

Replace with:

“All slab-on-ground reinforcing shall extend to within 75 mm of the outside edge of the slab (including the foundation wall) and shall consist of a minimum 2.27kg/m² welded Grade 500E reinforcing mesh sheets (1.14 kg/m² in each direction), which shall be lapped at sheet joints such that the overlap measurement between the outermost cross wires of each fabric sheet is equal to the greater of one of the following:

- the spacing of cross wires plus 50 mm;
- 150 mm; or
- the manufacturer’s requirements.

Slabs shall have a maximum dimension of 18 m between free joints.”

2.1.2 NZS 4229 Foundations where good ground has not been established.

COMMENT:

Foundations for houses built on ground that has the potential for liquefaction or lateral spread are outside the scope of B1/AS1.

The MBIE/MfE guidance document “Planning and engineering guidance for potentially liquefaction-prone land” outlines a risk-based process to identify and manage liquefaction-related risk in land use planning and development decision-making.

For houses built in areas that have the potential for liquefaction, the MBIE guidance document “Repairing and rebuilding houses affected by the Canterbury earthquakes” may be appropriate. This guidance provides a range of potential foundation solutions depending on expected ground movement and available bearing capacity. These parameters also determine the required degree of involvement of structural and geotechnical engineers and the extent of specific engineering design.

Amend 11
Aug 2011
Amend 12
Feb 2014

Amend 20
Nov 2021

Amend 19
Nov 2019

Amend
20 Nov 2021

Amend 19
Nov 2019

Amends
11 and 12

Amend
12 Feb 2014

Amend 14
Nov 2016

ARCHIVED

3.0 Timber

3.1 NZS 3604 subject to the following modifications:

3.1.0 Referenced Documents

Replace reference to AS/NZS 4671: 2001, in NZS 3604 with the 2019 version that is referenced in the Verification Method B1/VM1.

3.1.1 NZS 3604 Paragraph 1.3 Definitions

Add (in the definition for Good Ground):
"liquefaction, lateral spread," after
"subsidence" in subparagraph (c).

3.1.2 NZS 3604 Section 5 Bracing Design

Make the following amendments:

Amend Figure 5.4, Earthquake zones, so that all the area within the Christchurch City Council boundary is within Zone 2.

Amend Figure 5.4 Earthquake zones, so that the lowest zone within the Selwyn or Waimakariri District Council boundaries is within Zone 2. Areas within Selwyn District that are designated as Zone 1 in NZS 3604 shall become Zone 2.

3.1.2A NZS 3604 Clause 7.4.1.3

Delete Subclause 7.4.1.3 (c).

3.1.2B NZS 3604 Figure 7.10(b)

On the plan view replace the text "2/M12 x 250 mm coach screws at 140 crs" with "2/M12 x 240 mm coach screws at 140 crs vertically."

On the plan view replace "2/M12 at 400 crs" twice with "2 M12 bolts at 140crs vertically to capture end joist laminations and blocking, and boundary joist laminations and blocking, at post centrelines."

Add to Note 3: "All coach screws to have 50 x 50 washers."

3.1.2C NZS 3604 Figure 7.10(c)

On the plan view insert the text "At each strap location (at joist ends and nogging), 2/M12 x 240 mm long coach screws are required."

On the plan view, replace the text " 2/M12 x 250 mm coach screws at 140 crs vertically" with " 2/M12 x 200mm coach screws at 140 crs vertically."

On the section view, replace the text "M12 x 200 mm coach screws at 400 crs vertically" with M12 x 240 mm coach screws at 140 crs vertically.

Delete "2/M12 bolts at 400crs" which tie laminations together along edge joists and along boundary joists.

3.1.3 NZS 3604 Clause 7.5.2.3

Delete: Clause 7.5.2.3

Replace with: "Clause 7.5.2.3 The combined foundation and edge details shall be constructed as shown in Figures 7.13(B), 7.14(B) or (C) (and Figures 7.15(B) and 7.16(B) or (C) for foundations supporting a masonry veneer)."

3.1.4 NZS 3604 Figure 7.13

Delete: Figure 7.13(A) – Foundation edge details – In situ concrete – Dimensions & reinforcing for single storey.

Amend title of Figure 7.13(B) to "Dimensions & reinforcing for 1 or 2 storeys".

3.1.5 NZS 3604 Figure 7.14

Delete: Figure 7.14(A) – Foundation edge details – Concrete masonry – Single storey

Amend title of Figure 7.14(B) to "1 or 2 storeys", and add a note: "for a single storey foundation, 15 Series masonry may be used and the minimum footing width may be 190 mm".

COMMENT:

Unreinforced and untied slab to footing single storey option removed.

3.1.6 NZS 3604 Figure 7.15

Delete: Figure 7.15(A) – Masonry veneer foundation edge details – Dimensions and reinforcement for single storeys.

Amend 12
Feb 2014

Amend 20
Nov 2021

Amend 19
Nov 2019

Amend 11
Aug 2011

Amend 10
May 2011

Amend 11
Aug 2011

Amend 15
Jan 2017

Amend 15
Jan 2017

Amend 11
Aug 2011

Amend 11
Aug 2011

Amend 11
Aug 2011

Amend 11
Aug 2011
Amend 10
May 2011

ARCHIVED

COMMENT:

Unreinforced and untied slab to footing single storey options removed.

3.1.7 NZS 3604 Figure 7.16

Delete: Figure 7.16 (A) – Masonry veneer foundation edge details – Concrete masonry – Single storey.

COMMENT:

Unreinforced and untied slab to footing single storey option removed.

3.1.8 NZS 3604 Clause 7.5.8.1

Delete: Clause 7.5.8.1

Replace with: “Clause 7.5.8.1 All slab-on-ground floors shall be reinforced concrete in accordance with Clauses 7.5.8.3, 7.5.8.4 and 7.5.8.6.4. All reinforcing steel, including welded mesh, shall be Ductility Class E in accordance with AS/NZS 4671.”

Where Grade 500E welded steel mesh is specified, it shall meet the requirements of Paragraph 14.0 in B1/VM1.

3.1.9 NZS 3604 Clause 7.5.8.3

Delete: Clause 7.5.8.3

Replace with: “Clause 7.5.8.3 All slab-on-ground reinforcing shall extend to within 75 mm of the outside edge of the slab (including the foundation wall) and shall consist of a minimum 2.27 kg/m² welded reinforcing mesh sheets (1.14 kg/m² in each direction), which shall be lapped at sheet joints such that the overlap measurement between the outmost cross wires of each fabric sheet is equal to the greater of one of the following:

- the spacing of cross wires plus 50 mm,
- 150 mm or
- the manufacturer’s requirements.

Slabs shall have a maximum dimension of 24 m between free joints.”

3.1.10 NZS 3604 Clause 7.5.8.6.2

Delete: Clause 7.5.8.6.2

3.1.11 NZS 3604 Figure 7.18

Delete title: Figure 7.18 – Irregular slab (plan view) (see 7.5.8.6.2)

Replace with: “Figure 7.18 – Irregular slab (plan view) (see 7.5.8.6.4)”.

3.1.12 NZS 3604 Clause 7.5.8.6.3

Delete: Clause 7.5.8.6.3.

3.1.13 NZS 3604 New Clause

Add new: “Clause 7.5.8.8 Free Joints.

At free joints, slab reinforcement shall be terminated and there shall be no bonding between vertical concrete faces (prevented by using building paper or a bituminous coating). R12 dowel bars 600 mm long shall be placed at 300 mm centres along the free joint and lapped 300 mm with slab reinforcement on both sides of the joint. All dowel bars on one side of the joint shall have a bond breaker applied, e.g. by wrapping dowel bars for 300 mm with petrolatum tape. Joint dowel bars must be installed in a single plane, in true alignment and parallel.”

3.1.14 NZS 3604 Foundations where good ground has not been established

COMMENT:

Foundations for houses built on ground that has the potential for liquefaction or lateral spread are outside the scope of B1/AS1.

The MBIE/MfE guidance document “Planning and engineering guidance for potentially liquefaction-prone land” outlines a risk-based process to identify and manage liquefaction-related risk in land use planning and development decision-making.

For houses built in areas that have the potential for liquefaction, the MBIE guidance document “Repairing and rebuilding houses affected by the Canterbury earthquakes” may be appropriate. This guidance provides a range of potential foundation solutions depending on expected ground movement and available bearing capacity. These parameters also determine the required degree of involvement of structural and geotechnical engineers and the extent of specific engineering design.

ARCHIVED

3.2 Slab-on-ground in expansive soils

3.2.1 NZS 3604 Clause 1.1.2 Buildings covered by this Standard

Amend 1.1.2(a) to read:

“Buildings founded on good ground or on expansive soils where the requirements of 1.1.5 are met”

3.2.2 NZS 3604 New Clause

Add new: “Clause 1.1.5 Buildings on expansive soils

Buildings on expansive soils shall be supported on slab-on-ground foundations complying with 7.5.13 and in addition to 1.1.2 shall be limited as follows:

- (a) single storey, stand-alone household unit, and
- (b) maximum length or width of floor of 24.0 m including any attached garage, and
- (c) simple plan shapes such as rectangular, L, T or boomerang, and
- (d) concrete slab-on-ground with a minimum thickness of 100 mm and a minimum concrete compressive strength of 20 MPa, and
- (e) simple roof forms, incorporating hips, valleys, gables or mono pitches, and
- (f) maximum overall height of 7.0 m to roof apex from lowest cleared ground level, and
- (g) maximum roof height of 3.0 m, and
- (h) roof slope between 10° and 35° from the horizontal, and
- (i) maximum span of roof truss 12.0 m, and
- (j) external walls maximum of 2.4 m height studs, other than gable end walls and walls to mono-pitched roofs, which shall not exceed 4.0 m.

COMMENT:

Floor plans

Where floor plans incorporate re-entrant corners then continuity of the exterior ground beam shall be maintained by continuing it as an internal beam, with the exterior beam details continued for a length of at least 1.0 m into the internal beam. This is only applicable where internal beams are specified in Tables 7.4A and 7.4B. This is aimed to bring the solution in NZS 3604 in line with Clause 5.3.8 of AS 2870:2011.

Ground movement

Provision for the additional ground movement effects from trees near to foundations in expansive soils should be considered. Trees remove moisture from the soil for a radius equal to the height of the tree. This causes expansive soils to shrink to varying degrees, and when near houses leads to differential settlement occurring under foundations. Movement of the foundations may lead to cracks in the building and door jamming.

Where existing trees (including trees that have been recently removed) are located closer to the foundations than 1.5 times the mature height of a tree, then additional geotechnical advice should be obtained. Planting of new trees should be avoided near foundations of new buildings or neighbouring buildings on sites with expansive soils.

3.2.3 NZS 3604 Clause 7.5.1

Add the following paragraph at the end of Clause 7.5.1:

“Slabs on expansive soils for buildings meeting the requirements of 1.1.5 shall, in addition to meeting the requirements of 7.5.1 to 7.5.12, meet the requirements of 7.5.13. Where there is conflict the requirements of 7.5.13 shall apply.”

3.2.4 NZS 3604 New clause, tables and figures

Add new: **Clause 7.5.13 Slab-on-ground in expansive soils**

7.5.13.1 Identification of expansive soils

7.5.13.1.1 Should reasonable enquiry as outlined in 3.1.3 show any signs of expansive soils, the expansive soil class, as defined in AS 2870, shall be established by one or all of:

- (a) enquiry to the local territorial authority, and/or
- (b) reference to the certificate of suitability issued in terms of NZS 4431, and/or
- (c) a soil test undertaken by a suitably qualified soils engineer.

7.5.13.1.2 Expansive soil class shall be defined as:

- (a) Slightly ‘S’, having an I_{SS} range of 0–1.9%, and a 500 year design characteristic surface movement return (y_S) of 22 mm, or
- (b) Moderately ‘M’, having an I_{SS} range of 2.0–3.7% and a 500 year design characteristic surface movement return (y_S) of 44 mm, or

ARCHIVED

- (c) Highly 'H', having an I_{SS} range of 3.8–6.5% and a 500 year design characteristic surface movement return (y_S) of 78 mm, or
- (d) Extremely 'E', having an I_{SS} range of 6.6–7.5% and a 500 year design characteristic surface movement return (y_S) of 90 mm.

7.5.13.2 Maximum aspect ratio of concrete slabs

The aspect ratio of the concrete slabs or bays of concrete slabs, such as in the case of L, T or boomerang concrete slab shapes, shall not exceed 5 to 1 (length to width).

7.5.13.3 Foundation details

7.5.13.3.1 For the identified expansive soil class the foundation details, external and internal thickenings shall be as follows.

- (a) For light wall claddings refer to Table 7.4A and Figure 7.22.
- (b) For medium wall or heavy wall claddings refer to Table 7.4B and Figure 7.23.

7.5.13.3.2 Situations where no internal thickenings shall be required are limited to a rectangular slab with long side not exceeding 17.0 m. Where this limit is exceeded, add additional internal thickenings across the slab with the same cross section dimensions and reinforcing as the external footing, so that the centre to centre spacing of thickenings is always less than 17.0 m.

COMMENT:

Design constraints:

- a) The characteristic surface movements and the corresponding expansivity classifications have been calculated based on design for ultimate limit state (ULS) conditions for a 1 in 1000 year "extreme" drought event, and the serviceability limit state (SLS) conditions for a 1 in 500 year drought event.
- b) Maximum soil movements are calculated to be based on a 500 year return period for SLS, and a 1000 year return period for ULS*;

(*NB: This differed from the recommendations contained within BRANZ Study Report 120A (BSR120A) which used a 300 year return period for the design level drought conditions)

- c) Climate parameters adopted from BSR120A of $\Delta u = 1.2$ pF, $H_s = 1.5$ m, and a crack depth of 0.5 H_s
- d) The I_{SS} (shrink swell index) ranges attributed to the expansivity classifications as defined in 3.2.4 above have been calculated using the parameters presented in BSR120A and Equation 2.3.1 of AS 2870:2011.
- e) Sites subject to parameters that differ from those mentioned above, in particular sites where the crack depth is less than 0.75 m, such as cut natural ground or clay backfill, require specific engineering assessment to confirm their appropriate site classification.
- f) The effects of nearby trees (whether existing, recently removed, or future planting) are not considered in these solutions. It is recommended that specific geotechnical engineering advice is obtained where a tree is within a lateral distance of 1.5 times its mature height of the foundations.

Maintenance of foundations in expansive soils

Normal maintenance is that work generally recognised as necessary to achieve the expected performance over time of the foundation located on expansive soils. Unless otherwise specified by the designer and noted on the drawings, basic normal maintenance tasks should ensure that:

- a) the drainage and wetting of the site is controlled so that extremes of wetting and drying of the soils are prevented, and
- b) the position and operation of gardens adjacent to the dwelling are controlled, and the planting of trees near to foundations is suitably restricted, and
- c) any leaks which develop in plumbing, storm water or sanitary sewage systems are repaired promptly.

Amend
20 Nov 2021

Amend 19
Nov 2019

Amend 19
Nov 2019

ARCHIVED

Table 7.4A Reinforced concrete foundations in expansive soils for light wall claddings
Clause 7.5.13 and Figure 7.22

Expansive soil class	Slightly 'S'	Moderately 'M'	Highly 'H'	Extremely 'E'
Soil embedment (De)	375 mm	525 mm	575 mm	625 mm
Top steel (A _S top)	2/D 16	2/ D16	2/ D16	2/ D16
Bottom steel (A _S bottom)	1/ D16	1/ D25	1/ D20	1/ D25
Stirrups	R6/ 125 crs.	R6/ 125 crs.	R6/ 300 crs.	R6/ 300 crs.
Maximum spacing of internal thickenings	no internal thickening	no internal thickening	2.5 m crs.	2.5 m crs.
Depth of thickening (D1)	–	–	400 mm	450 mm
Base width (B1)	–	–	300 mm	350 mm
Top steel (A _S top)	–	–	2/ D20	2/ D20
Bottom steel (A _S bottom)	–	–	2/ D16	2/ D20
Stirrups	–	–	R6/ 150 crs.	R6/ 150 crs.

Table 7.4B Reinforced concrete foundations in expansive soils for medium wall and heavy wall claddings
Clause 7.5.13 and Figure 7.23

Expansive soil class	Slightly 'S'	Moderately 'M'	Highly 'H'	Extremely 'E'
Soil embedment (De)	500 mm	550 mm	775 mm	800 mm
Top steel (A _S top)	2/ D16	2/ D20	2/ D20	3/ D20
Bottom steel (A _S bottom)	2/ D16	2/ D16	2/ D20	2/ D20
Stirrups	R6/ 125 crs.	R6/ 250 crs.	R6/ 300 crs.	R6/ 300 crs.
Maximum spacing of internal thickenings	–	2.5 m crs.	2.5 m crs.	2.5 m crs.
Depth of thickening (D1)	–	350 mm	450 mm	500 mm
Base width (B1)	–	300 mm	300 mm	350 mm
Top steel (A _S top)	–	2/ D16	3/ D20	3/ D20
Bottom steel (A _S bottom)	–	2/ D16	2/ D16	2/ D20
Stirrups	–	R6/ 125 crs.	R6/ 150 crs.	R6/ 150 crs.

Amend 19
Nov 2019

ARCHIVED

Figure 7.2.2 Reinforced concrete foundations in expansive soils for light wall claddings
Clause 7.5.13 and Table 7.4A

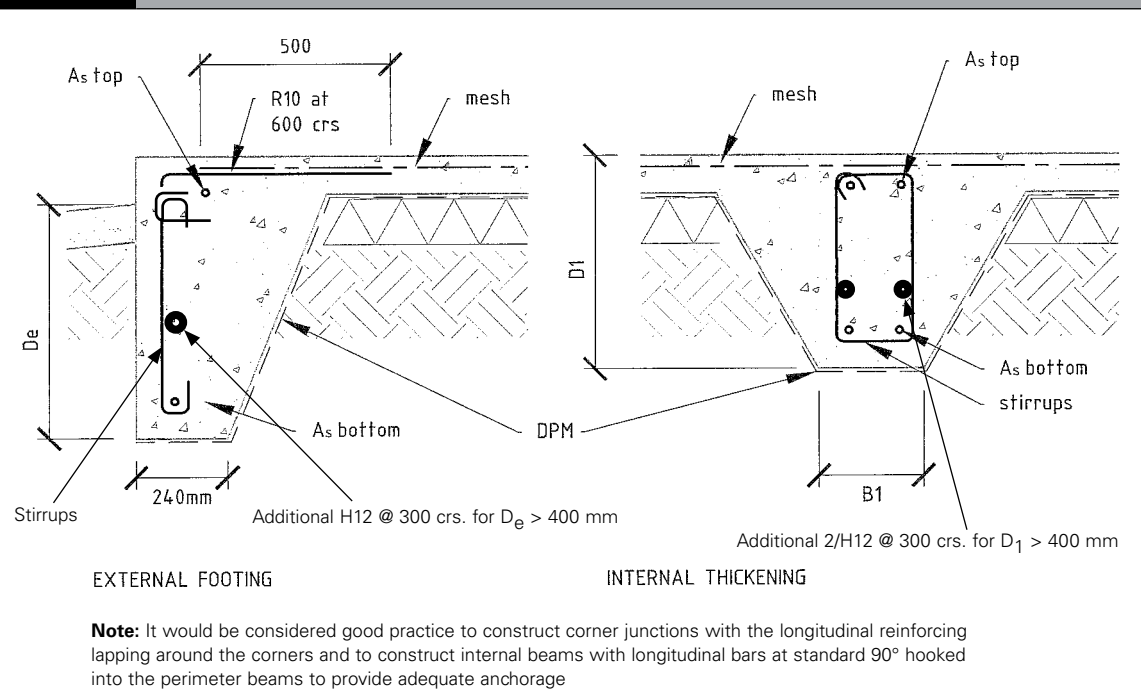
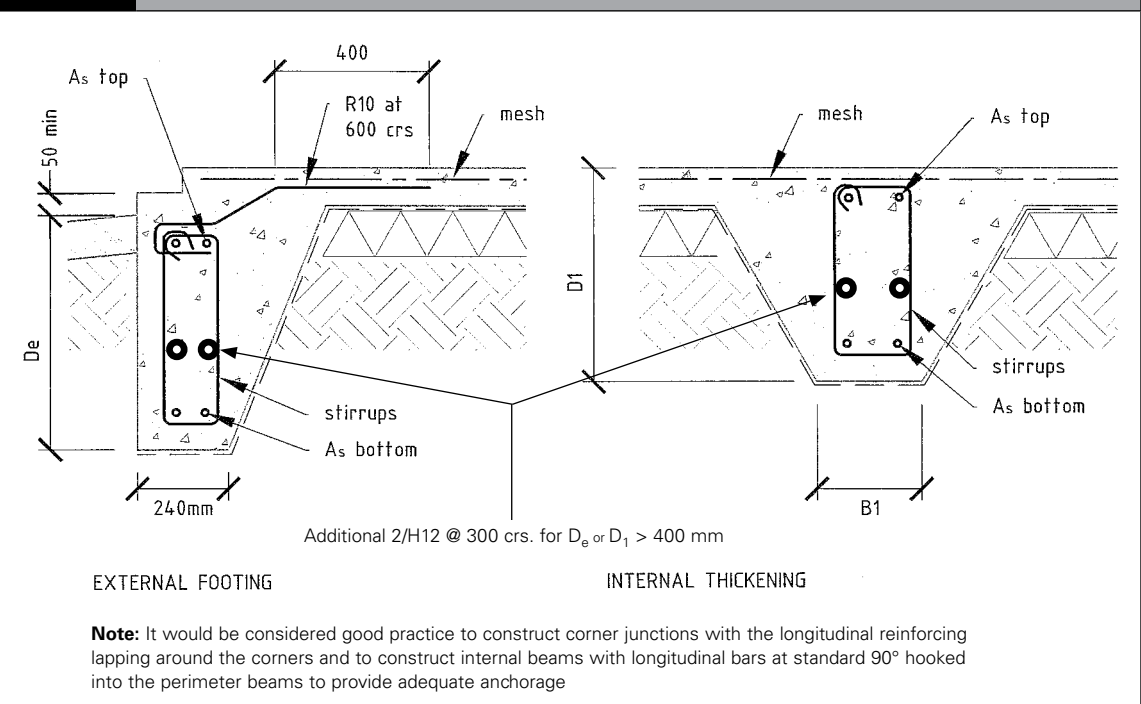

Figure 7.2.3 Reinforced concrete foundations in expansive soils for medium wall and heavy wall claddings
Clause 7.5.13 and Table 7.4B



4.0 Earth Buildings

Amend 11
Aug 2011

4.1 NZS 4299 subject to the following modifications:

Amend 11
Aug 2011

4.1.1 NZS 4299, Paragraph 1.3 Definitions

Add (in the definition for Good Ground):

Amend 19
Nov 2019

“liquefaction, lateral spread,” after
“subsidence” in subparagraph (c).

Amend 11
Aug 2011

4.1.2 NZS 4299, Clause 2.3 Earthquake zones

Add to the end of Clause 2.3:

“The earthquake zone factor > 0.6 shall apply to the *Canterbury earthquake region*.”

Amend 11
Aug 2011

4.1.3 NZS 4299, Figure 2.1 Earthquake zones

On the map shown in NZS 4299 Figure 2.1 Earthquake zones, the *Canterbury earthquake region* shall be interpreted as having an earthquake zone factor of > 0.6.

Amend 11
Aug 2011

4.1.4 NZS 4299, Clause 4.8.6.

Delete: Clause 4.8.6

Replace with: “Clause 4.8.6 The thickness and reinforcement and detail of concrete slabs shall comply with the requirements of NZS 3604 as modified in B1/AS1 Paragraph 3.1.”

Amend 10
May 2011

4.1.5 NZS 4299 Foundations where good ground has not been established

COMMENT:

Foundations for houses built on ground that has the potential for liquefaction or lateral spread are outside the scope of B1/AS1.

The MBIE/MfE guidance document “Planning and engineering guidance for potentially liquefaction-prone land” outlines a risk-based process to identify and manage liquefaction-related risk in land use planning and development decision-making.

For houses built in areas that have the potential for liquefaction, the MBIE guidance document “Repairing and rebuilding houses affected by the Canterbury earthquakes” may be appropriate. This guidance provides a range of potential foundation solutions depending on expected ground movement and available bearing capacity. These parameters also determine the required degree of involvement of structural and geotechnical engineers and the extent of specific engineering design.

Amend 19
Nov 2019

Amend 11
Aug 2011

Amend 12
Feb 2014

5.0 Stucco

5.1 NZS 4251

Amend 19
Nov 2019

Amend 10
May 2011



ARCHIVED

6.0 Drains

**6.1 AS/NZS 2566.1, including
Amendment 1**

**6.2 AS/NZS 2566.2, including
Amendments 1, 2 and 3**

6.3 AS/NZS 2032

6.4 AS/NZS 2033

7.0 Glazing

Amends
9, 11, 15

7.1 NZS 4223.1

7.2 NZS 4223.2

7.3 NZS 4223.3

7.3.1 Clause 22.4.3 modified

Delete clause 22.4.3

Replace with:

“22.4.3 Structural glass barriers

Structural glass barriers use glass as a structural element and are normally classified by the following types. Glass design for these types shall comply with the following tables (see note 1):

Table 14 - Structural balustrade – cantilevered glass;

Table 15 - Structural balustrade – two-edge point fixed;

Table 16 - Structural balustrade – two-edge support;

Table 17 - Structural balustrade – three-edge support.

Design types and glass types not shown in Tables 14 to 17 require specific design.

All structural glass barriers safeguarding a fall of 1000 mm or more shall have interlinking rails, which in the event a glass pane breaks, spans the broken pane at the required barrier height and,

- i) resists Line and Concentrated design loads (SLS) specified in Tables 14 to 17, and
- ii) does not deflect more than 100 mm, in any direction, under the design loads.

Interlinking rails are not required for a heat-strengthened or toughened laminated safety glass barrier that:

- (a) has a top capping, corner brackets or a proprietary system and will, when both panes of the laminate are fractured, resist a 0.2 kN concentrated load and not deflect more than 250 mm (see note 2), or
- (b) has two or three edges supported by structural sealant joints or continuous

clamps, and will, when both panes of the laminate are fractured, resist a 0.2 kN concentrated load and not deflect more than 250 mm (see note 2), or

- (c) has a stiff interlayer and will, when both panes of the laminate are fractured, resist a 0.2 kN concentrated load and not deflect more than 250 mm (see note 2). Physical testing must be undertaken to demonstrate compliance with the load and deflection requirements for laminated glass barriers with a stiff interlayer (see note 3).

Physical testing of glass barriers must include all components of the barrier system, including all structural connections. Loads and deflections must be applied and measured horizontally, at midspan, at the required barrier height. The concentrated load shall be applied over an area of 100 mm x 100 mm and for at least one minute.

NOTE –

- (1) The design of structural connections, fasteners and mounting hardware, that are part of the glass barrier, is outside the scope of this Standard and must be specifically designed.
- (2) Laminated glass is susceptible to minor edge delamination, depending on the interlayer type and laminating process. Normally this will not affect the mechanical properties but can be noticeable on exposed edges.
- (3) Test results for dual pane fracture of laminated glass barriers with stiff interlayers are not applicable to barriers that have narrower glass panes than that tested”

7.4 NZS 4223.4

8.0 Small Chimneys

See Acceptable Solution B1/AS3.

9.0 Steel

9.1 NASH Standard Part 2 Light Steel Framed Buildings

Amend 15
Jan 2017

Amend 13
Jun 2016

Amend 11
Aug 2011

Amend 12
Feb 2014

Amend 18
Jun 2019

Verification Method B1/VM2 Timber Barriers

ARCHIVED

No specific test methods have been adopted for verifying compliance of timber barriers with NZBC Performance B1.

ARCHIVED

Acceptable Solution B1/AS2 Timber Barriers

ARCHIVED

No specific Acceptable Solution has been adopted for compliance of timber barriers with NZBC Performance B1. The previous Acceptable Solution for Timber barriers has been removed. It is intended that the Department's Barrier Guide will provide design guidance for several barrier types.

Pages 28–34 deleted by Amendment 11

ARCHIVED

Verification Method B1/VM3 Small Chimneys

ARCHIVED

No specific test methods have been adopted for verifying compliance of small chimneys with NZBC Performance B1.

ARCHIVED

Acceptable Solution B1/AS3

Small Chimneys

ARCHIVED

Scope

This acceptable solution applies to small *chimneys* and to supporting *hearth* slabs for solid fuel burning domestic appliances. It is to be read in conjunction with Acceptable Solution C/AS1 Part 7, which has additional requirements to prevent outbreak of *fire*.

1.0 Chimney Construction

1.1 General

1.1.1 Type

The acceptable solutions described in this document are for *chimneys* built of brickwork, concrete or precast pumice concrete, that are connected to timber frame or masonry *buildings* complying with NZS 3604 or NZS 4229.

1.1.2 Height

The height of any *chimney* measured from the top of the *chimney* foundation slab to the top of the *chimney* stack shall not exceed 9 m. *Chimneys* shall not cantilever more than 2.4 m above the fixing at roof level (refer Paragraph 1.7).

1.1.3 Size

The width (measured along the *building* line) and depth (measured perpendicular to the *building* line) shall not exceed:

- a) For the foundation and *chimney* base

– precast pumice concrete	1600 mm wide	
		x 1050 mm deep
– brickwork or concrete	1200 mm wide	
		x 1050 mm deep
- b) For a brick *chimney* stack

– single skin (see Figure 2)	500 mm wide	
		x 500 mm deep
– double skin (see Figure 3)	1200 mm wide	
		x 680 mm deep
- c) For a concrete or precast pumice concrete *chimney* stack

	1200 mm wide	
		x 700 mm deep

1.1.4 Chimney liners

Where *chimney* liners are used they are to be separated from the *chimney* to ensure free thermal movement. This shall be achieved by coating the liner with a suitable debonding agent or by wrapping it in a *combustible* material no less than 0.25 mm thick.

1.2 Chimney wall thickness

1.2.1 *Chimney* wall thicknesses shall be no less than:

- a) Brick

– single skin (see Figure 2)	155 mm
– double skin (see Figure 3)	245 mm
- b) Concrete 170 mm
- c) Precast pumice concrete 85 mm

These thicknesses apply to the *chimney* stack, *gather* and *chimney* base.

1.3 Foundations

1.3.1 *Chimneys* shall be built on a foundation comprising walls and slab for suspended floors (see Figure 1(a)), or on a thickened slab for floor slabs on ground (see Figure 1(b)).

1.3.2 The *chimney* foundation slab shall be constructed in reinforced concrete, founded on *good* ground, and have:

- a) A thickness of no less than 200 mm, and be placed at a depth of no less than 300 mm below surrounding ground level.
- b) Reinforcement as shown in Figure 1.
- c) D12 starters at 400 mm maximum centres, to match vertical steel locations in the *chimney*.

Amends
5 and 15

1.3.3 The *chimney* foundation walls shall be 150 mm thick reinforced concrete, 190 mm thick concrete masonry, or brick *construction* complying with Figures 2 or 3. Vertical and horizontal reinforcing steel shall be as given in Paragraph 1.6.

ARCHIVED

Figure 1: Chimney Foundation
Paragraphs 1.3.1, 1.3.2 b) and 1.4.1, and Figures 2, 3, 4 and 5

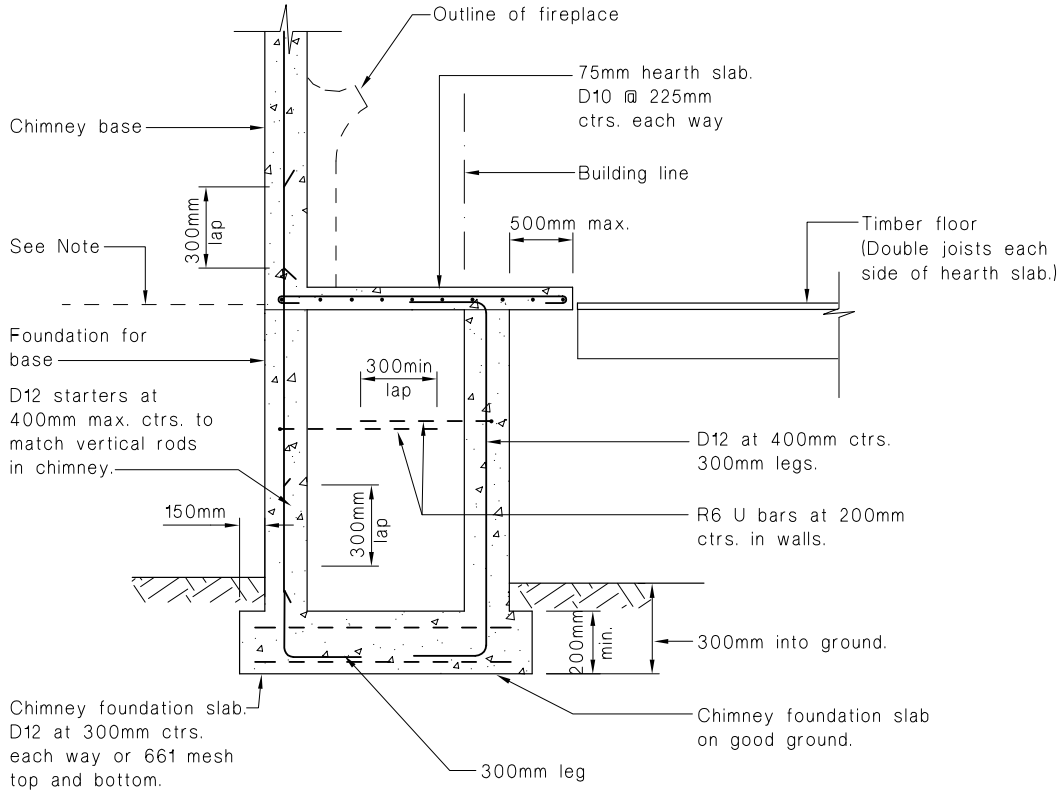

(a) Suspended floor

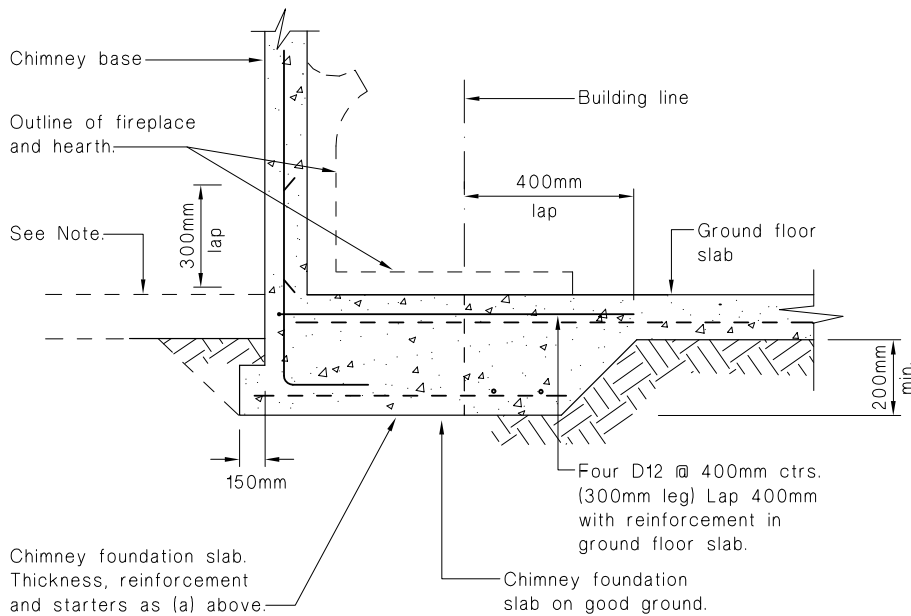

(b) Slab on ground

NOTE:
Figures 1(a) and 1(b) have been drawn for the chimney being exterior to the building. The dotted line indicates the timber floor in Figure 1(a) and the ground floor slab in Figure 1(b) for the situation where the chimney is internal.

ARCHIVED

Figure 2: Brick Chimney with Liner
Paragraphs 1.1.3 b), 1.2.1 a), 1.3.3, 1.6.1, 1.7.2, 1.7.5 and 1.7.6

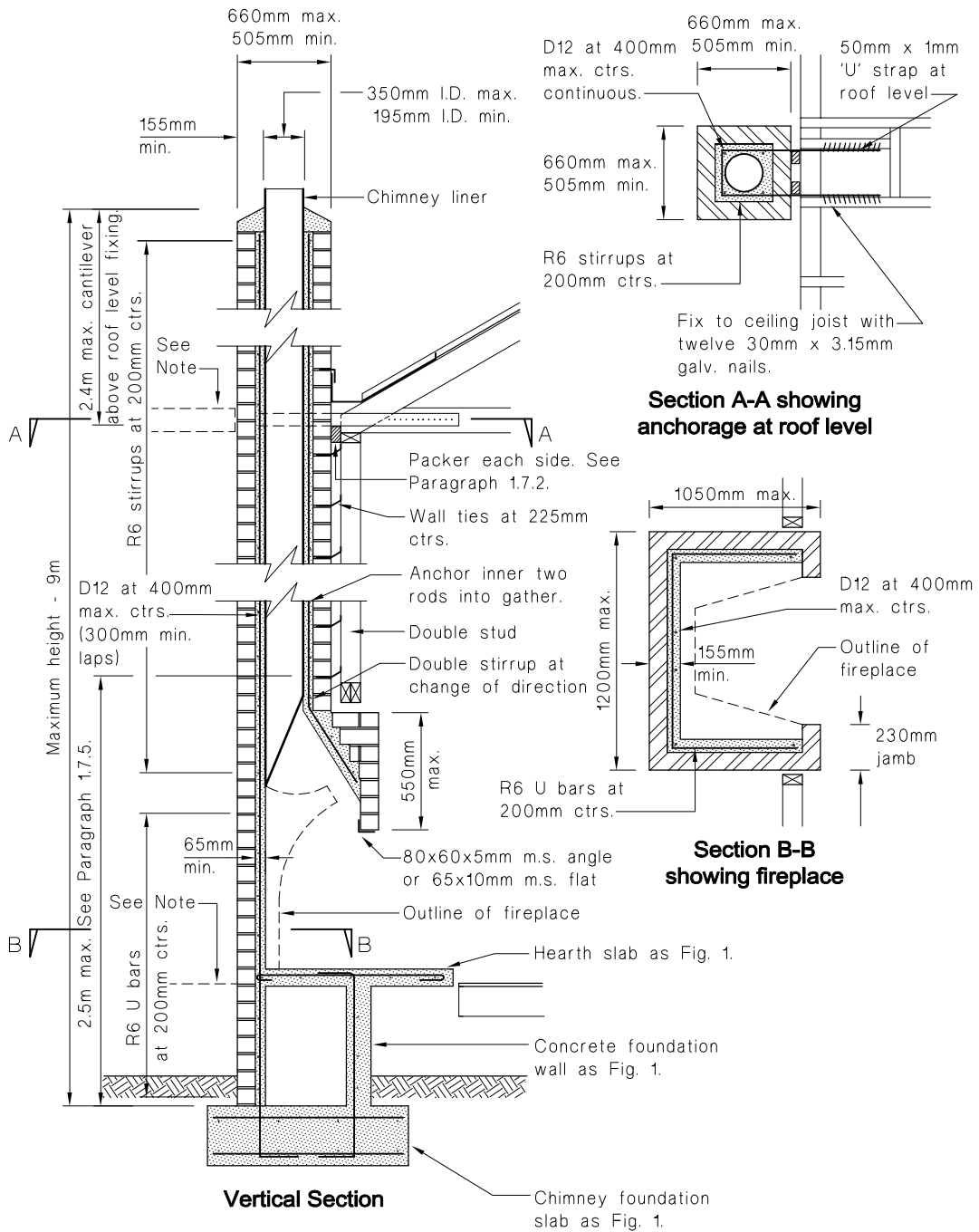

NOTES:

Figure 2 has been drawn for the chimney being exterior to the building. The dotted lines indicate the ceiling joists and floor for the situation where the chimney is internal.

Flues must be sized to ensure adequate draught. Sizing depends on many factors including the height of the flue but generally flue cross sectional area needs to be a minimum of 1/12th of the fireplace opening. The flue also needs to be sufficiently large to enable cleaning. 195mm is regarded as a practical minimum diameter.

Amend 2
Aug 1994

Amend 2
Aug 1994

ARCHIVED

Figure 3: Brick Chimney Without Liner
Paragraphs 1.1.3 b), 1.2.1 a), 1.3.3, 1.6.1, 1.7.2, 1.7.5 and 1.7.6

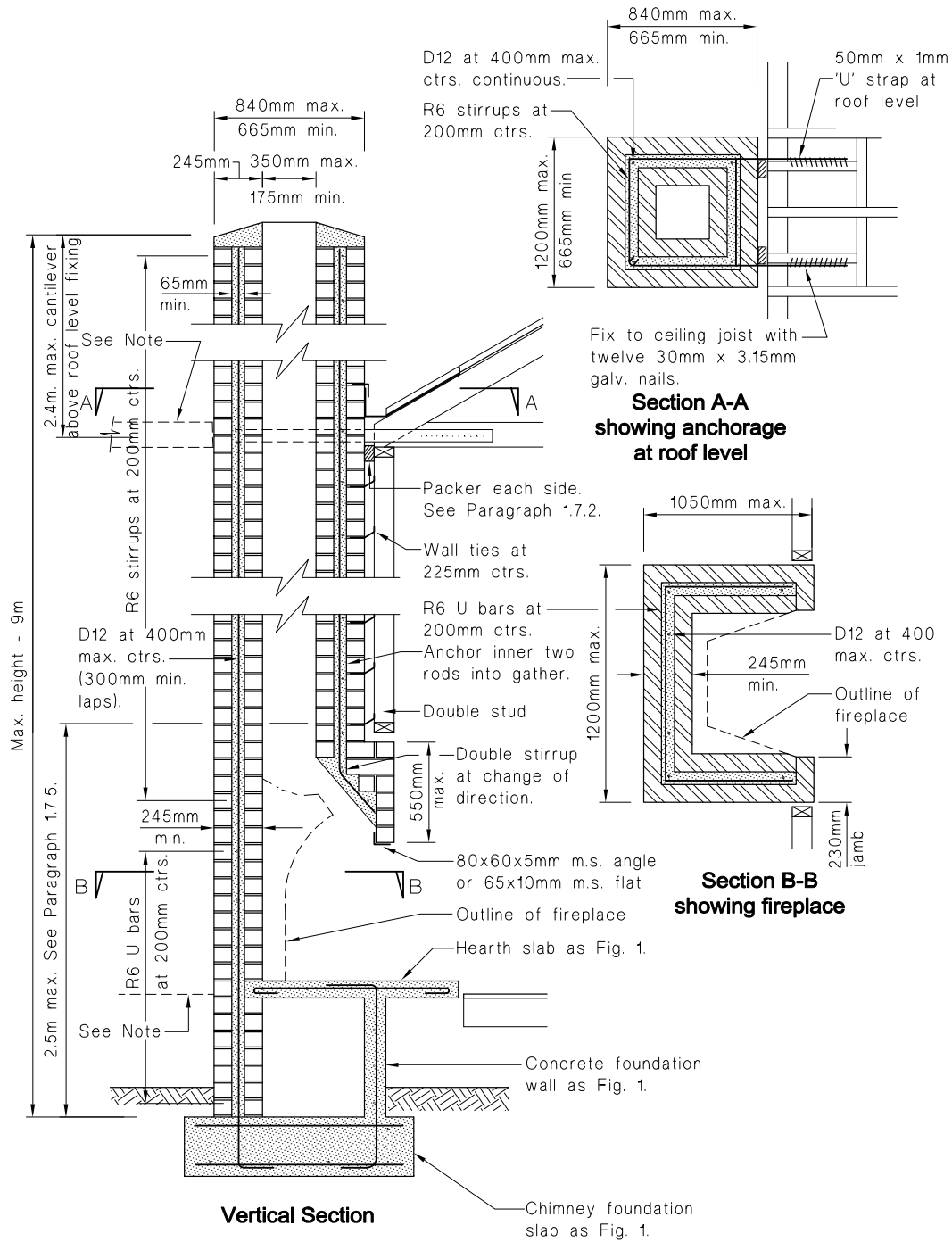

NOTES:

- Figure 3 has been drawn for the chimney being exterior to the building. The dotted lines indicate the ceiling joists and floor for the situation where the chimney is internal.
- Flues must be sized to ensure adequate draught. Sizing depends on many factors including the height of the flue but generally flue cross sectional area needs to be a minimum of 1/12th of the fireplace opening. The flue also needs to be sufficiently large to enable cleaning. 175 x 175 mm is regarded as a practical minimum size.

Amend 2
Aug 1994

Amend 2
Aug 1994

ARCHIVED

1.4 Hearths

1.4.1 *Hearth* slabs shall be of concrete no less than 75 mm thick, reinforced with D10 bars located centrally at 225 mm centres each way. See Figure 1.

1.5 Chimney breasts

1.5.1 The widths of openings in *chimney breasts*, and their supporting lintels, shall comply with Table 1.

Table 1: Chimney Breast Openings and Lintels Paragraph 1.5.1 and Figure 4	
Opening width	Lintel reinforcing
Brick 1.0 m maximum	65 x 10 mm m.s. flat or 80 x 60 x 5 mm m.s. angle
Concrete Up to 900 mm 900 – 1500 mm	Two D10 rods D12 upper rod D16 lower rod
Precast pumice 1.0 m maximum	Two D10 rods
<p>Note: Horizontal reinforcing rods to concrete and precast pumice are to be placed one above the other at a spacing of 75 mm, and have R6 ties at 150 mm maximum centres.</p>	

1.6 Reinforcing

1.6.1 Reinforcing of foundation walls, *chimney bases* (including the *gathers*) and *chimney stacks* (see Figures 2 to 5 inclusive) shall comprise:

- a) D12 bars at 400 mm maximum centres vertically. Laps in bars shall be no less than 300 mm.
- b) R6 bars at 200 mm centres horizontally. These will be in the form of closed stirrups in the stack and U bars elsewhere.
- c) Double horizontal reinforcing at any change in direction of the vertical steel (e.g. at the *gather/stack* intersection).

1.6.2 Bars which do not extend for the full height of the *chimney* shall be stopped in the *gather*:

- a) In reinforced concrete and brick, by continuing these bars through to the far face of the *gather* and terminating with a 200 mm leg.
- b) In precast pumice concrete, by anchoring the last 200 mm of the bar in a high strength cementitious grout. (See Figure 5.) Refer Paragraph 1.8.3 g) for grout details.

1.7 Chimney restraint

1.7.1 *Chimneys* which are not constructed integrally with the *building* shall be secured by floor and roof brackets. An acceptable alternative for brick and precast pumice concrete *chimneys* is that they be restrained by a roof tie used in conjunction with closely spaced wall ties. (Refer Paragraphs 1.7.5 to 1.7.16.)

1.7.2 Where a packer (see Figures 2, 3, 6 and 7(b)) is shown between the *chimney* and *building* it shall be:

- a) Concrete, brick, steel (angle, channel or Z section), or any insulating material which has a long term operating temperature of no less than 150°C,
- b) Secured in place to prevent it dislodging, and
- c) Capable of withstanding a compressive force of 10 kN without shortening by more than 1.5 mm.

COMMENT:

C/AS1 Part 7 requires a 50 mm separation between the *chimney* and any *combustible* material. Where the *chimney* fixing described does not prevent the *chimney* moving within this gap, a packer is shown.

Amends 5 and 15

1.7.3 Floor and roof brackets

The brackets shall comprise a 50 mm x 4 mm hot dip galvanised steel strap placed around the *chimney*. Each leg of the strap shall be horizontal and shall be bolted to the joists with three M12 bolts at 75 mm centres as shown in Figure 6.

ARCHIVED

Figure 4: Reinforcing Details – Concrete and Brick Chimneys
Paragraph 1.6.1

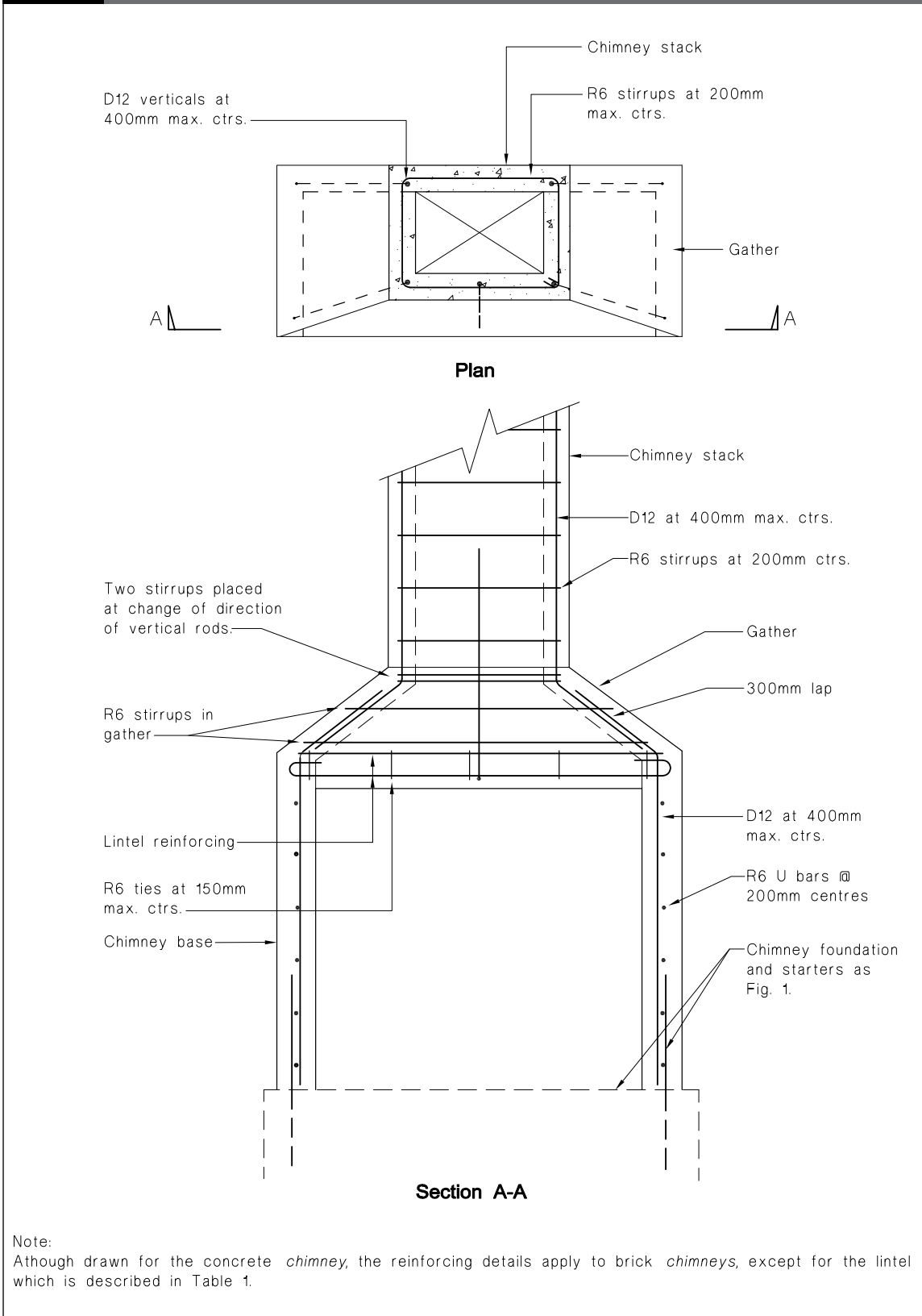

ARCHIVED

Figure 5: Reinforcing Details – Precast Pumice Concrete Chimney
Paragraphs 1.6.1 and 1.6.2 b)

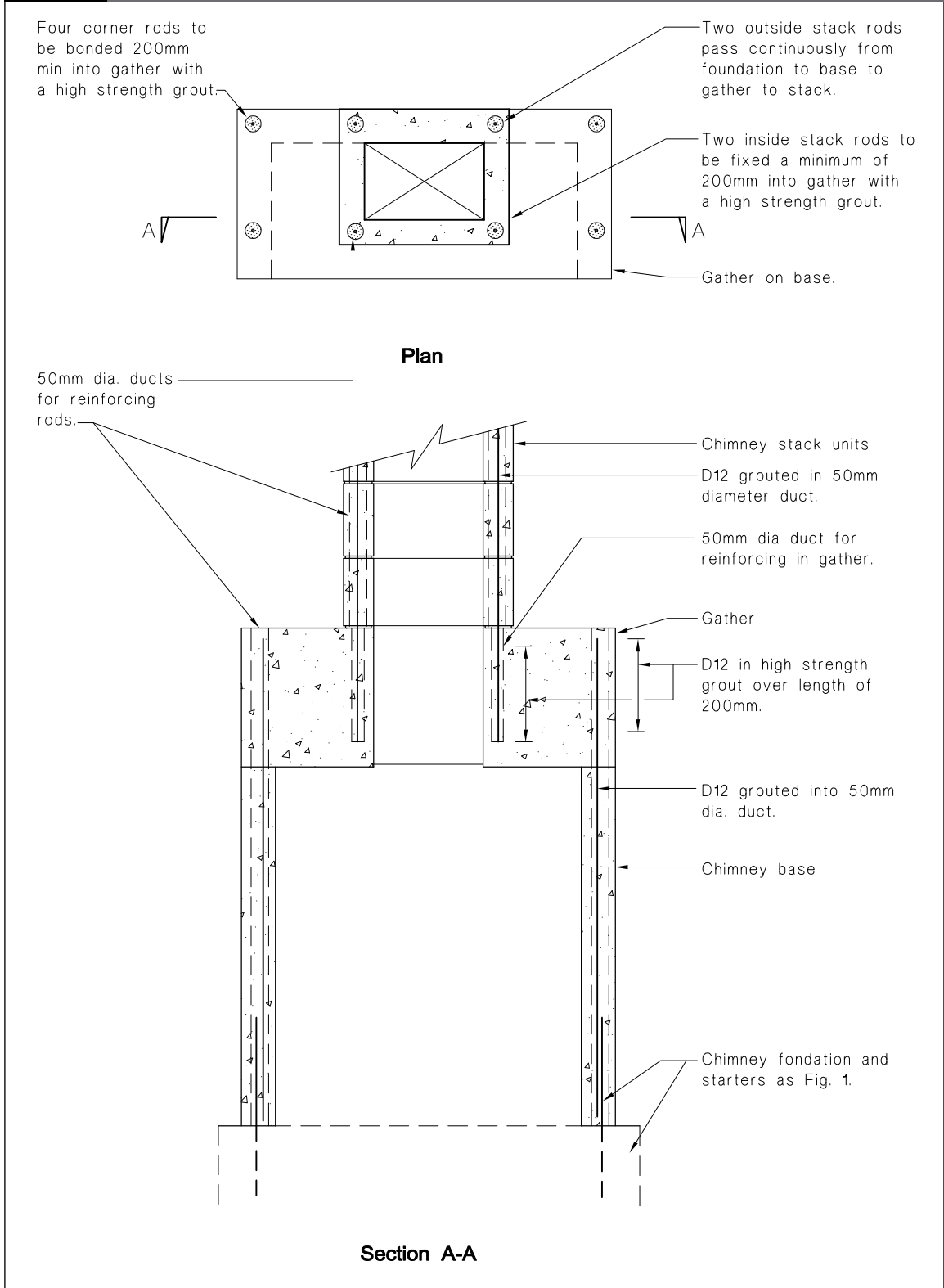

ARCHIVED

Amend 9
Sep 2010

1.7.4 Brackets shall be located so that the distance between the top of the *chimney* foundation slab and the first bracket, and the distance between adjacent brackets does not exceed 3.0 m. Where a *chimney* foundation wall is integral with a *building* foundation wall, then the height to the first bracket may be measured from the top of the *building* foundation wall.

1.7.5 Alternative fixing using roof tie and closely spaced wall ties

This alternative *chimney* fixing shall apply only from the *gather* to roof level. It requires that either the top of the *chimney* foundation slab or a floor bracket complying with Paragraph 1.7.3 be located within a distance of 2.5 m below the first of the closely spaced wall ties. (See Figures 2 and 3.) If the latter applies, the *chimney* below this bracket shall be fixed by floor brackets spaced in accordance with Paragraph 1.7.4.

1.7.6 Brick chimneys

Brick *chimneys* shall be restrained at roof level by a zinc coated 50 x 1.0 mm mild steel 'U' strap used in conjunction with closely spaced wall ties. The strap shall be:

- a) Cast into the grout and wrap around the reinforcing steel (see Figures 2 and 3),
- b) Placed at no more than 20° from the horizontal,
- c) Used in conjunction with a packer (complying with Paragraph 1.7.2) placed at the same level, and
- d) Fixed with twelve 30 x 3.15 mm galvanised nails to roof or ceiling framing.

1.7.7 Wall ties (see Figure 7(a)) shall be located in mortar joints at 225 mm maximum centres up each side of the *chimney*, except that pairs of ties shall be used for *chimneys* wider than 600 mm.

1.7.8 Wall ties shall be constructed from either 4 mm diameter galvanised bar or 25 x 1.5 mm zinc coated steel strip capable of withstanding a load of 1.2 kN without elongating or shortening by more than 1.5 mm.

1.7.9 Where zinc coating of components is required it shall be no less than 300 g/m² in accordance with AS 1397.

1.7.10 Nails used to fix straps to roof or ceiling framing shall be spaced at no less than 35 mm in Radiata Pine, and 70 mm in other timbers.

1.7.11 Acceptable alternatives to the cast-in 'U' strap are:

- a) Any proprietary bracing strip system of equal durability to the 'U' strap described in Paragraph 1.7.6, and capable of carrying a seismic force of 12 kN without elongating by more than 1.5 mm, or
- b) A cast-in hot dip galvanised, deformed 6.0 mm reinforcing bar bent to a 'U' shape, with each end fixed to the roof or ceiling framing with six 50 x 4.0 mm galvanised fencing staples.

1.7.12 The 'U' strap or either of the acceptable alternatives may be wrapped around the outside of the *chimney* rather than be cast-in, provided that if strap is used it shall be painted with a zinc rich primer.

1.7.13 Precast pumice concrete chimneys

Precast pumice concrete *chimneys* shall be restrained at roof level either by a 50 x 1 mm 'U' strap wrapped around the *chimney*, or by a hot dip galvanised deformed 6 mm reinforcing bar placed into the grout around the reinforcing steel, together with either fixing brackets or fixing ties (see Figure 7(b)). Straps and bars shall satisfy the relevant requirements of Paragraphs 1.7.6 to 1.7.12.

1.7.14 Fixing brackets (see Figure 7(b)) shall be made from 5.0 mm thick mild steel angle and drilled with:

- a) A 50 mm diameter hole to suit the reinforcing duct location, and
- b) A 14 mm diameter hole for the 12 mm diameter coach screw fixing to the double stud.

1.7.15 Fixing brackets shall be located in mortar joints between the units, and be spaced at no less than 480 mm centres for stacks up to 600 mm wide, and no less than 320 mm centres for stacks wider than 600 mm.

ARCHIVED

Figure 6: Chimney Restraint – Floor and Roof Brackets
Drawn for Roof Restraint
Paragraphs 1.7.2 and 1.7.3

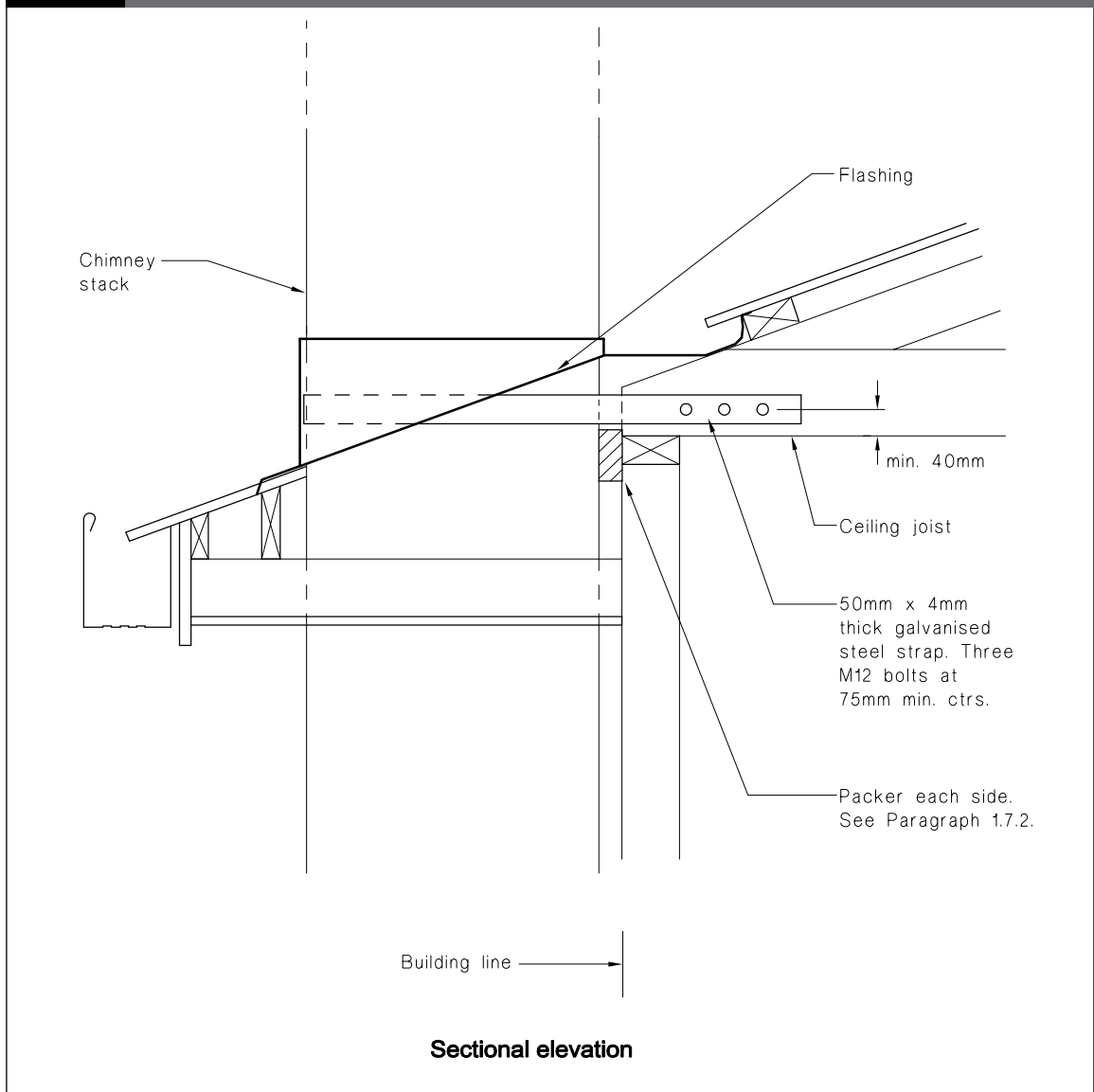

Note:
Although drawn for a chimney on an exterior wall, the bracket details also apply to an interior chimney.

ARCHIVED

Figure 7: Chimney Restraint
Paragraphs 1.7.2, 1.7.7, and 1.7.13

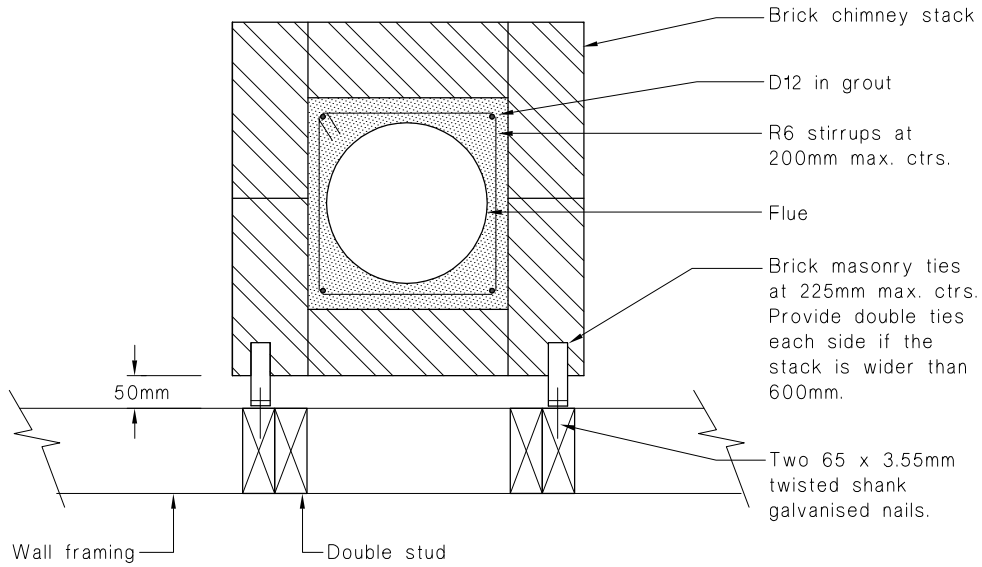

(a) Brick chimney

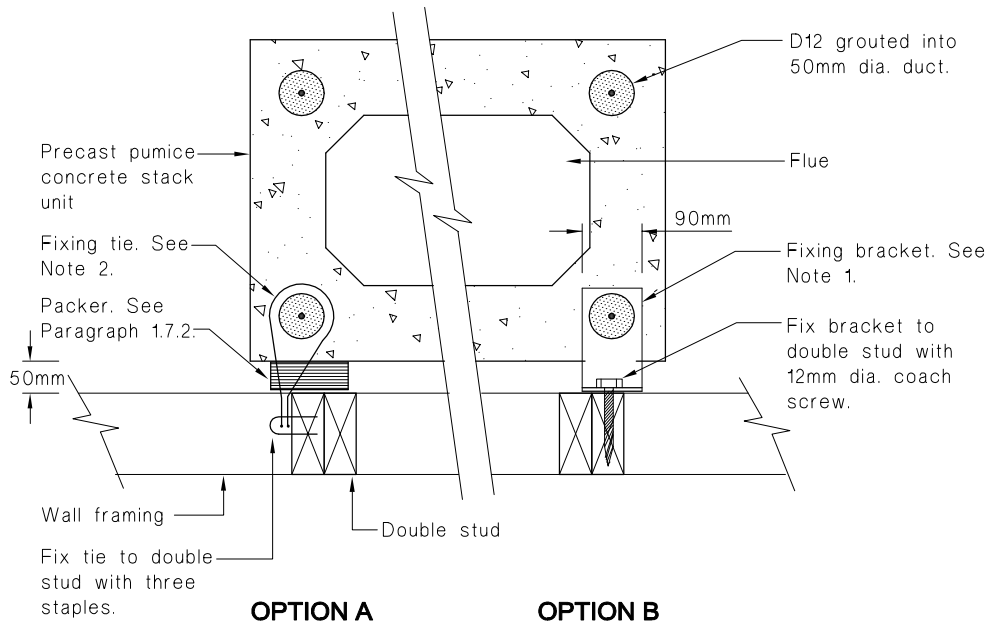

OPTION A

OPTION B

(b) Precast pumice concrete chimney

Notes:

1. Brackets shall be made from 5 mm thick m.s. angle drilled with 50 mm dia. hole to suit the reinforcing duct. Locate brackets in the mortar joints between units at no more than:
 - 480 mm maximum centres for stacks up to 600 mm wide
 - 320 mm maximum centres for stacks over 600 mm wide
2. Ties shall comprise 4 mm galvanised hairpins located in the mortar joint between units at no more than:
 - 320 mm maximum centres for stacks up to 600 mm wide
 - 160 mm maximum centres for stacks over 600 mm wide

ARCHIVED

1.7.16 Fixing ties shall comprise 4 mm galvanised wire hairpins, which are hooked behind the reinforcing ducts and secured to the required adjacent double studding with four heavy duty fencing staples. The ties shall be located in mortar joints between the units and be at no less than 320 mm centres for stacks up to 600 mm wide, and no less than 160 mm centres for stacks wider than 600 mm.

1.8 Materials and construction

1.8.1 Brickwork

Brick *chimney* construction shall conform to the relevant sections of NZS 4210.

1.8.2 Concrete

Chimneys, foundations and *hearth* slabs of reinforced concrete, shall comply with the relevant clauses of NZS 3109 for ordinary grade concrete.

1.8.3 Precast pumice concrete

Pumice concrete units for use in precast *chimneys* shall:

- a) Have pumice aggregate which:
 - i) is free of *combustible* and organic matter, and
 - ii) has a maximum aggregate size of no greater than 19 mm, with at least 40% but not more than 60% of the aggregate retained by a 4.75 mm standard test sieve, and
- b) Have a mix ratio by volume of no more than five parts of mixed pumice aggregate to one part of cement,
- c) Have a compressive strength of no less than 7 MPa at 28 days when cured and tested in accordance with NZS 3112: Part 2,
- d) After adequate curing, be air dried and kept under cover during storage, transport and on the site,
- e) Be laid dry. (Work left unfinished should be protected from rain.)
- f) Be joined with mortar which complies with NZS 4210, and

- g) Have ducts filled with grout complying with NZS 4210, except over the last 200 mm where bars are anchored in the *gather* (refer Paragraph 1.6.2 b)). At these locations a non-shrinking cement-based grout, which attains a minimum compressive strength of 30 MPa at 7 days, shall be used.

1.8.4 Concrete masonry

Concrete masonry *construction* for *chimney* foundation walls shall conform to the relevant sections of NZS 4229.

1.8.5 Reinforcing steel

Reinforcing used in *chimneys* is to conform to AS/NZS 4671, and shall:

- a) For brick, be embedded centrally in the thickness of the grout,
- b) For in-situ concrete, have cover to the steel in accordance with NZS 3109,
- c) For precast pumice concrete, be placed with grout in the preformed ducts in the units.

1.8.6 Hot dip galvanising

Hot dip galvanising shall comply with AS/NZS 4680.

1.9 Systems to resist horizontal earthquake loadings

1.9.1 The bracing described in Paragraphs 1.9.2 to 1.9.6 shall be provided in those *buildings* where one or more of the following apply:

- a) The area of the room containing the *chimney* exceeds 24 m²,
- b) The length of the wall on which the *chimney* is located exceeds 3.5 m between supporting braced walls which are perpendicular to it. This length may be increased to 6.5 m where the wall is supported, at each floor level and at the roof or ceiling level, by either a structural diaphragm which conforms with the relevant requirements of NZS 3604 or by dragon ties. The dragon ties shall:

Amend 9
Sep 2010

Amend 9
Sep 2010

ARCHIVED

Amend 5
Jul 2001

- i) consist of a continuous length of 100 x 50 mm timber fixed in accordance with NZS 3604 clauses 8.3.3.3 and 8.3.3.4,
 - ii) be run as a pair, with one dragon tie going from the wall on which the *chimney* is located, back to each of the supporting braced walls. The enclosed angle between the wall on which the *chimney* is located and each dragon tie shall be 60°, and
 - iii) be located no more than 1.5 m out from each supporting braced wall.
- c) The floor area on any level of the *building*, for a given *chimney* type (see Table 2), is less than:
- i) 50 m² for *chimney* Type 1,
 - ii) 75 m² for *chimney* Types 2, 3 and 4,
 - iii) 150 m² for *chimney* Types 5, 6 and 7.

1.9.2 The *building* supporting the *chimney* shall contain bracing elements to resist earthquake loads from the *chimney*. These loads are applied at roof level and at each floor to which the *chimney* is connected. The bracing elements necessary are additional to those required by NZS 3604 or NZS 4229.

1.9.3 The number of bracing units to be provided for each *chimney* connection (see Paragraph 1.9.4) is given in Table 2. The number of bracing units to be provided at any level shall be the sum of the bracing units required at each of the *chimney* connections above the level being considered. The earthquake bracing units at roof and floor connections required for chimneys constructed in accordance with B1/AS3 shall be determined for the *Canterbury earthquake region* from Table 2 for Earthquake zone A.

Amend 10
May 2011

COMMENT:

As an example: for a standard precast pumice concrete *chimney* in a two storey *building* in Zone A, that is connected to the *building* by a roof bracket and by floor brackets at ground and first floor, the number of bracing units required are:

Location	Bracing units required
– Just below roof level	60
– Just below first floor level	60 + (60% of 60) = 96
– Just below ground floor level	60 + (60% of 60) + 60 = 156

1.9.4 A *chimney* shall be considered as connected to the *building* when:

- a) At roof level: it is held either by a roof bracket or by a roof tie,
- b) At ground floor level: it is held by a floor bracket or the *chimney base* is integral with the *building* foundation wall,

Table 2: Bracing Units Required for Each Chimney Connection to Resist Earthquake Loadings
Paragraphs 1.9.1c) and 1.9.3

Chimney construction	Type	Max size of chimney:		Number of bracing units required at the roof connection and at each floor connection according to earthquake zone: (See Note 1)		
		Stack	Base	Zone A	Zone B	Zone C
Precast pumice						
– standard	1	500 x 400	1600 x 1050	60	50	40
– large	2	1100 x 400	1600 x 1050	110	90	70
Brick						
– single skin	3	500 x 500	1200 x 1050	90	70	60
– double skin	4	590 x 590	1200 x 1050	130	100	80
	5	1200 x 680	1200 x 1050	240	200	160
Concrete	6	590 x 590	1200 x 1050	210	170	140
	7	1200 x 700	1200 x 1050	390	320	260

Note:

- 1. The number of bracing units required at floor connections other than the ground floor shall be taken as 60% of the value given in the table.

ARCHIVED

c) At an intermediate floor level: it is held either by a floor bracket or by closely spaced wall ties spanning the floor.

1.9.5 For earthquake ground movement in the direction perpendicular to the wall on which the *chimney* is located, structural diaphragms shall be provided at roof/ceiling level and at each floor level to which the *chimney* is connected. The diaphragms shall comply with all relevant clauses of NZS 3604 and NZS 4229.

1.9.6 For earthquake in the direction parallel to the wall on which the *chimney* is located, the bracing units required as determined from Paragraph 1.9.3 shall be provided solely by that wall.

2.0 Solid Fuel Burning Domestic Appliances

2.1 Chimneys

2.1.1 *Chimneys* for solid fuel burning appliances shall comply with Paragraph 1.0 or with the relevant sections of AS/NZS 3869 and AS/NZS 2918 for sheetmetal *chimneys*.

Amend 9
Sep 2010

2.2 Hearth slab

2.2.1 Solid fuel burning domestic appliances weighing no more than 130 kg shall be supported on a 65 mm thick *hearth* slab that is:

- a) Reinforced with 665 mesh, or D10 rods at 300 mm centres each way, placed centrally in the slab thickness,
- b) Supported on a timber or concrete floor, or integral with a concrete floor. (The floor supporting the *hearth* slab shall comply with NZS 3604 or NZS 4229 as appropriate), and
- c) Comprised of ordinary grade concrete complying with the relevant clauses of NZS 3109.

2.2.2 *Hearth* slabs on a timber floor shall be held in position by supporting members on all four sides of the *hearth*. These members shall each be held by four screws with a minimum shank diameter of 4.88 mm that penetrate the floor framing by 50 mm.

2.2.3 *Hearth* slabs on concrete floors shall be secured in position by four D10 starter rods. The rods shall be located in each corner of the *hearth* slab and they shall terminate each end with standard hooks complying with NZS 3109.

Spread of fire

2.2.4 Paragraphs 2.2.1 to 2.2.3 provide an acceptable structural solution, but depending on the particular installation, different *hearth* dimensions may be necessary to meet the spread of *fire* requirements of NZBC Clause C2.2. *Hearth* slabs for solid fuel burning appliances shall comply with AS/NZS 2918.

Amend 2
Aug 1994

Amend 15
Jan 2017
Amend 9
Sep 2010
Amend 5
Jul 2001

ARCHIVED

Verification Method B1/VM4 Foundations

ARCHIVED

(Revised by Amendment 4)

1.0 Scope and Limitations

1.0.1 This document covers the ultimate limit state design of foundations, including those of earth retaining structures. Methods are given for determining ultimate bearing and lateral sliding strengths.

1.0.2 This document does not describe a means of determining the value of the soil parameters used in the document (e.g. c^l , ϕ^l and s_u). The derivation of these parameters, which must be based on the most adverse moisture and groundwater conditions likely to occur, is outside of the scope of this verification method.

COMMENT:

Appendix A contains information on the types of investigations that may need to be conducted to determine the soil parameters.

1.0.3 Serviceability limit state deformations are not covered in this document. The determination of such deformations and their acceptability to the design in question needs to be considered but is outside the scope of this document.

COMMENT:

Appendix B contains information which may be of assistance in designing for serviceability limit state deformations.

It is intended that design provisions to cover serviceability limit state deformations be added to the document in the future.

1.0.4 This document assumes general ground or slope stability and provides methods only for ensuring against local failure of the foundation. Overall ground stability needs to be verified before this document can be applied; this is outside the scope of this verification method.

1.0.5 This document must not be used to design foundations on loose sands, saturated dense sands or on cohesive soils having a sensitivity greater than 4.

COMMENT:

Saturated sands may be subject to liquefaction during earthquake loading and sensitive clays exhibit a rapid decrease in undrained shear strength once the peak strength has been mobilised. The design of foundations on these materials needs special considerations which are not covered in this verification method.

1.0.6 This document shall not be used for foundations subject to continuous vibration.

COMMENT:

Although this document covers foundations subject to vibration from earthquake loading it does not cover those applications where foundations are subject to continuous vibration such as from the operation of certain machinery.

1.0.7 The "Comments" and "Informative Appendices" of this document provide comment, background or general information but do not form part of this verification method.

COMMENT:

Appendix C contains a worked example showing how some of the provisions of this document are used.

2.0 General

2.0.1 Foundations must be designed for the load combinations given in AS/NZS 1170 Part 0, as amended by B1/VM1. *Strength reduction factors* given in this document must be used to determine the design strength of the foundation. The design loadings must not cause the foundation's design strength to be exceeded.

2.0.2 The design procedures of this document must be performed by a person who, on the basis of experience or qualifications, is competent to apply them.

2.0.3 The *building's* foundation elements or the elements of earth retaining structures shall be designed in accordance with the appropriate material Standards, as given in B1/VM1.

2.0.4 Foundations may be shallow or deep. A shallow foundation is one in which the depth

Amend 8
Dec 2008

Amend 8
Dec 2008

ARCHIVED

from the ground surface to the underside of the foundation is less than five times the width of the foundation. All other foundations are considered to be deep.

2.0.5 In assigning values for soil parameters the worst groundwater condition shall be considered.

COMMENT:

For cohesive soils the fully saturated condition will generally give the lowest strength and stiffness.

2.0.6 Foundation strength for cohesive soil depends on loading duration and whether consolidation can occur. For this reason the distinction is made between short term (e.g. initial load application, earthquake actions or wind gusts) and long term loading (e.g. permanent loads such as foundation dead load). For the short term case no consolidation occurs and the calculations shall be in terms of undrained shear strength (i.e. shear strength of the soil s_u) and total stress. For long term loading, full consolidation occurs and the calculations shall be in terms of drained shear strength and effective stress (i.e. soil parameters being cohesion, c^l , and the angle of shearing resistance ϕ^l).

2.0.7 For cohesionless soils consolidation occurs very quickly so drained strength shall be used in all cases.

2.0.8 Supervision and verification of soil parameters

Design assumptions and soil parameters shall be verified during *construction*. The designer shall nominate what supervision, including verification of soil parameters, will be undertaken during the *construction* period.

3.0 Shallow Foundations

3.1 General Provisions

3.1.1 The ultimate bearing strength shall be based on the most adverse moisture and groundwater conditions likely to occur.

3.1.2 Founding depths in clay soils known to exhibit swelling and shrinking behaviour shall be chosen so that the underside of the

foundation is beneath the zone of soil affected by shrinking and swelling caused by seasonal weather changes, and the root systems of nearby trees and shrubs.

3.1.3 Consideration shall be given to the possibility of any surcharge adjacent to a shallow foundation being removed during the life of the foundation, so reducing the available ultimate bearing strength.

3.1.4 Foundations subject to moment loading shall not be proportioned such that the point of application of the reaction force on the underside of the foundation is closer to the edge than $B/6$, for a rectangular foundation, or $r/2$, for a circular foundation.

3.2 Ultimate and design bearing strength and design bearing pressure

3.2.1 The design bearing pressure q_d shall be determined by dividing the design vertical forces (derived from combinations of factored vertical loads) by the effective area of the foundation. See Paragraph 3.3 for notation and the definition of effective area.

3.2.2 The ultimate bearing strength q_u is that pressure, exerted on the ground by the *building* foundation, which causes the ground to fail by mobilisation of all available shear strength. It shall be evaluated using the provisions of Paragraph 3.3.

3.2.3 The design bearing strength q_{dbs} shall be determined by multiplying the ultimate bearing strength by the appropriate *strength reduction factor* (see Paragraph 3.5.1).

3.2.4 The design bearing pressure shall not exceed the design bearing strength.

3.3 Ultimate limit state bearing strength for shallow foundations

3.3.1 The procedures specified in the following text apply to foundations of any size. The formulae are limited to soil profiles that for a depth beneath the underside of the foundation of at least two times the foundation width can be represented with single values for the density, angle of shearing resistance,

ARCHIVED

cohesion, and if appropriate, undrained shear strength.

Notation:

- A^l effective foundation area (m^2). For a rectangular foundation $A^l = B^l L^l$. For a circular foundation see Figure 2.
- B foundation breadth (m).
- B^l the smaller of $2(X + e_b)$ and $2(B - X - e_b)$ (see Figure 1) (m).
- D_e minimum horizontal distance from the edge of the underside of the foundation to the face of an adjacent downward slope (m).
- D_f depth to the underside of the foundation (m).
- H design horizontal load, the resultant of the factored horizontal forces applied to the foundation (kN).
- H_{uf} unfactored horizontal foundation load (kN).
- L foundation length (m).
- L^l the smaller of $2(Y + e_l)$ and $2(L - Y - e_l)$ (see Figure 1) (m).
- M_b design moment applied about an axis parallel to the breadth direction of the foundation (kNm).
- M_c design moment applied to a circular footing (kNm).
- M_l design moment applied about an axis parallel to the length direction of the foundation (kNm).
- N_{cr} , N_q , N_γ bearing strength factors.
- P_p ultimate lateral resistance derived from passive earth pressure (kN).
- R reaction on underside of foundation = $q_d A^l$ (kN).
- S ultimate shear strength between the base of the foundation and the ground (kN).
- V design factored vertical foundation load (kN).
- V_{uf} unfactored vertical foundation load (kN).
- V^l effective design factored vertical load = $V - u_f A^l$ (kN).
- X the distance from the edge of the foundation, along the x axis, to the point

of application of the design vertical foundation load V (m).

- Y the distance from the edge of the foundation, along the y axis, to the point of application of the design vertical foundation load V (m).
- Z the distance from the edge of a circular foundation, along the z axis, to the point of application of the design vertical foundation load V (m).
- c cohesion (kPa).
- c^l effective stress cohesion (kPa).
- e_b M_l/V (positive when R is further along the x axis than V , see Figure 1) (m).
- e_c M_c/V (positive when R is further along the z axis than V , see Figure 2) (m).
- e_l M_b/V (positive when R is further along the y axis than V , see Figure 1) (m).
- q vertical total stress in ground adjacent to the foundation at depth D_f (kPa).
- q^l vertical effective stress (σ_v^l) in ground adjacent to the foundation at depth D_f (kPa).
- q_d design bearing pressure = V/A^l (kPa).
- q_u ultimate bearing strength (kPa).
- q_{dbs} design bearing strength = $\Phi_{bc} q_u$ (kPa).
- r radius of a circular foundation (m).
- s_u undrained shear strength (kPa).
- u pore water pressure at a given position in the soil profile (kPa).
- u_f pore water pressure at depth D_f (kPa).
- x axis through design vertical foundation load V in direction of foundation breadth. The axis starts at the foundation edge and is positive in the direction towards V .
- y axis through design vertical foundation load V in direction of foundation length. The axis starts at the foundation edge and is positive in the direction towards V .
- z axis through the centre of a circular foundation and the design vertical foundation load V . The axis starts at the foundation edge and is positive in the direction towards V .

ARCHIVED

- γ soil unit weight (kN/m³).
- γ^l soil unit weight required for effective stress analysis for soil beneath the water table = $\gamma - \gamma_w$ (kN/m³).
- Γ γ when the water table is deeper than 2B beneath the underside of the foundation and γ^l when the water table is above this.
- γ_w water unit weight (kN/m³).
- Φ_{bc} *strength reduction factor* for bearing strength (see Paragraph 3.5.1).
- Φ_{pp} *strength reduction factor* for resistance derived from passive earth pressure (see Paragraph 3.5.1).
- Φ_{sl} *strength reduction factor* for sliding resistance (see Paragraph 3.5.1).
- ϕ angle of shearing resistance (degrees).
- ϕ^l effective stress angle of shearing resistance (degrees).
- σ_v^l vertical effective stress at a given depth in the soil profile = $\sum \gamma_i T_i - u$ where γ_i is the unit weight and T_i is the thickness of the *i*th soil layer above the depth at which σ_v^l is required (kPa).
- ω slope, below horizontal, of the ground adjacent to the edge of the foundation (degrees).

3.3.2 Ultimate bearing strength

The general expression for the ultimate bearing strength for a shallow foundation subject to vertical, shear, and moment loading is:

$$q_u = c\lambda_{cs}\lambda_{cd}\lambda_{ci}\lambda_{cg}N_c + q\lambda_{qs}\lambda_{qd}\lambda_{qi}\lambda_{qg}N_q + \frac{1}{2}\Gamma B^l\lambda_{\gamma s}\lambda_{\gamma d}\lambda_{\gamma i}\lambda_{\gamma g}N_\gamma$$

For undrained analysis ($\phi = 0$) use the following form of the general equation:

$$q_u = s_u\lambda_{cs}\lambda_{cd}\lambda_{ci}\lambda_{cg}N_c + \lambda_{qg}q$$

For drained analysis use the following form of the general equation:

$$q_u = c^l\lambda_{cs}\lambda_{cd}\lambda_{ci}\lambda_{cg}N_c + q^l\lambda_{qs}\lambda_{qd}\lambda_{qi}\lambda_{qg}N_q + \frac{1}{2}\gamma^l B^l\lambda_{\gamma s}\lambda_{\gamma d}\lambda_{\gamma i}\lambda_{\gamma g}N_\gamma$$

The bearing strength factors are obtained from Figure 3 or the following equations:

$$N_q = e^{\pi \tan \phi} \tan^2 \left(45 + \frac{\phi}{2} \right)$$

where *e* is the mathematical constant = 2.7183

$$N_c = (N_q - 1) \cot \phi \text{ for } \phi > 0, \text{ but has a value of } 5.14 \text{ for } \phi = 0$$

$$N_\gamma = 2(N_q - 1) \tan \phi$$

The λ factors in the above equation are:

a) Shape factors: λ_{cs} , λ_{qs} and $\lambda_{\gamma s}$

where:

$$\lambda_{cs} = 1 + \left(\frac{B^l}{L^l} \right) \left(\frac{N_q}{N_c} \right)$$

$$\lambda_{qs} = 1 + \left(\frac{B^l}{L^l} \right) \tan \phi$$

$$\lambda_{\gamma s} = 1 - 0.4 \left(\frac{B^l}{L^l} \right)$$

b) Depth factors: λ_{cd} , λ_{qd} and $\lambda_{\gamma d}$

where:

- for $\phi = 0$ and $\frac{D_f}{B^l} \leq 1$:

$$\lambda_{cd} = 1 + 0.4 \left(\frac{D_f}{B^l} \right)$$

- for $\phi = 0$ and $\frac{D_f}{B^l} > 1$:

$$\lambda_{cd} = 1 + 0.4 \tan^{-1} \left(\frac{D_f}{B^l} \right), \text{ where } \tan^{-1} \text{ is in radians}$$

Amend 15
Jan 2017

ARCHIVED

Figure 1: Bearing Strength Stress Block for a Shallow Rectangular Foundation Subject to Vertical Load and Moment
Paragraph 3.3.1

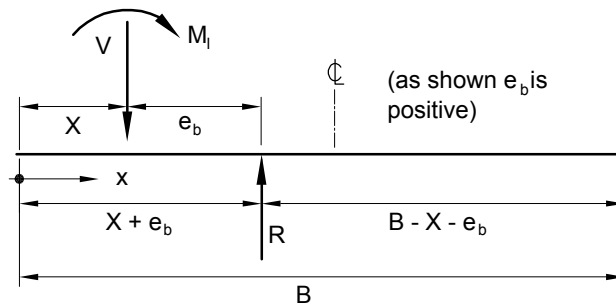

(a) Cross-section through foundation width

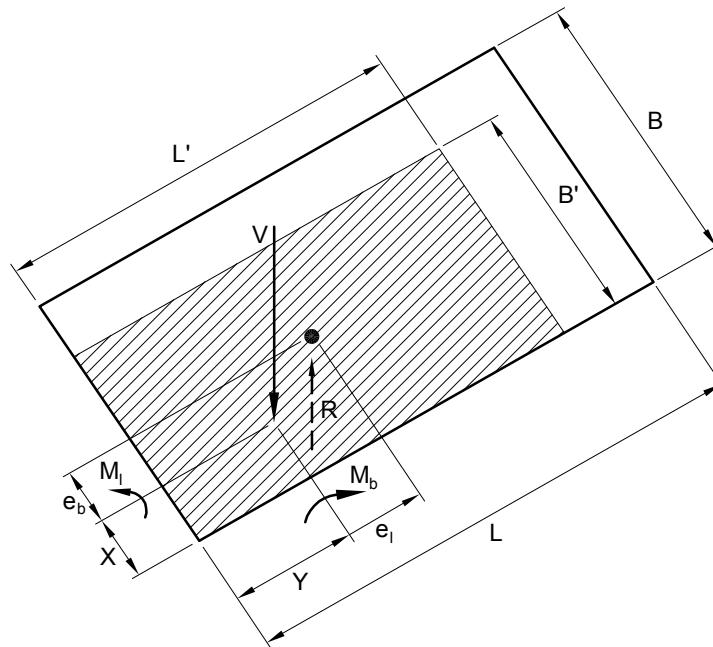

(b) Plan showing effective area of foundation

Notes:

1. Section (a) above drawn through foundation width. Section through foundation length similar.
2. B' is the smaller of $2(X + e_b)$ and $2(B - X - e_b)$. Similarly L' is the smaller of $2(Y + e_b)$ and $2(L - Y - e_b)$.
3. M can be applied anywhere on the foundation and does not have to be applied at the location of V .

ARCHIVED

Figure 2: Effective Foundation Area for a Circular Foundation Subject to Vertical Load and Moment
Paragraph 3.3.1

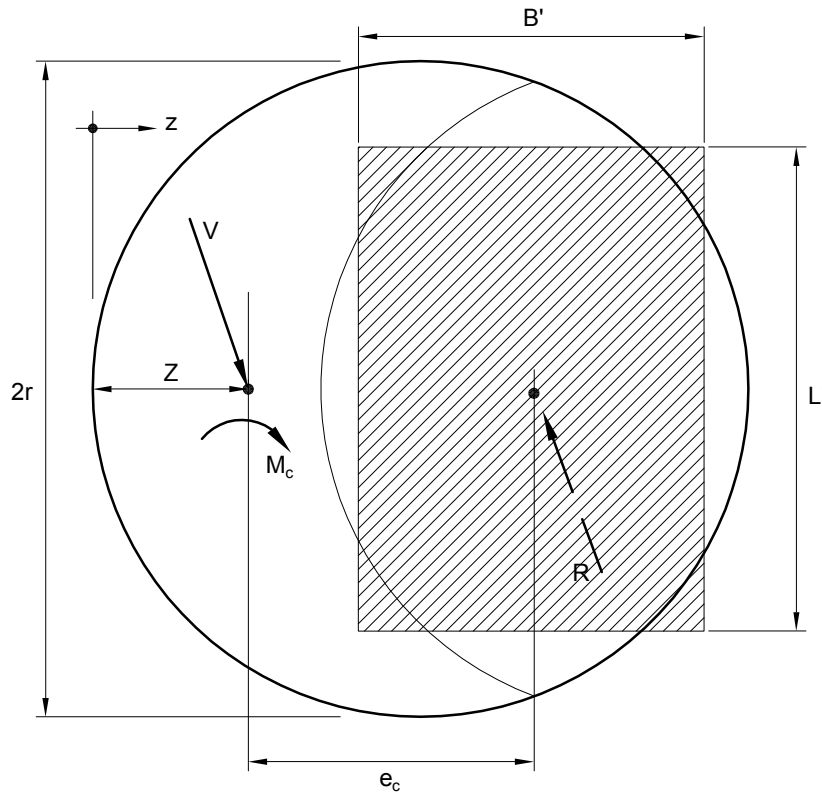

Notes

Effective area A' shall be represented by an equivalent rectangle of length L' and breadth B' , where:

$$A' = 2 r^2 \left[\cos^{-1} (\xi) - \xi \sqrt{1 - \xi^2} \right] \quad (\text{Note: } \cos^{-1} (\xi) \text{ is in radians.})$$

$$B' = \left(\frac{1 - \xi}{1 + \xi} \right)^{0.25} \sqrt{A'}$$

$$L' = \left(\frac{1 + \xi}{1 - \xi} \right)^{0.25} \sqrt{A'}$$

where:

$$\xi = \frac{e_c + Z - r}{r} \quad \text{when } e_c + Z \geq r, \text{ or } \frac{r - e_c - Z}{r} \quad \text{otherwise}$$

Amend 8
Dec 2008

ARCHIVED

- for $\phi > 0$:

$$\lambda_{qd} = \lambda_{qd} - \frac{(1 - \lambda_{qd})}{N_q \tan \phi}$$

- for $\frac{D_f}{B^l} \leq 1$:

$$\lambda_{qd} = 1 + 2 \tan \phi (1 - \sin \phi)^2 \left(\frac{D_f}{B^l} \right)$$

- for $\frac{D_f}{B^l} > 1$:

$$\lambda_{qd} = 1 + 2 \tan \phi (1 - \sin \phi)^2 \tan^{-1} \left(\frac{D_f}{B^l} \right),$$

where \tan^{-1} is in radians

- for all cases

$$\lambda_{\gamma d} = 1$$

- c) Load inclination factors: λ_{ci} , λ_{qi} and $\lambda_{\gamma i}$

where:

- for $\phi = 0$

$$\lambda_{ci} = 0.5 \left(1 + \sqrt{1 - \frac{H}{A' s_u}} \right)$$

$$\lambda_{qi} = 1$$

- for $\phi > 0$

- for horizontal loading parallel to L^l

$$\lambda_{qi} = \lambda_{\gamma i} = 1 - \frac{H_{uf}}{(V_{uf} + A' c^l \cot \phi^l)}$$

$$\lambda_{ci} = \frac{\lambda_{qi} N_q - 1}{N_q - 1}$$

- for horizontal loading parallel to B^l

$$\lambda_{qi} = \left(1 - \frac{0.7 H_{uf}}{V_{uf} + A' c^l \cot \phi^l} \right)^3$$

$$\lambda_{\gamma i} = \left(1 - \frac{H_{uf}}{V_{uf} + A' c^l \cot \phi^l} \right)^3$$

$$\lambda_{ci} = \frac{\lambda_{qi} N_q - 1}{N_q - 1}$$

- d) Ground inclination factors: λ_{cg} , λ_{qg} and $\lambda_{\gamma g}$

For horizontal ground $\lambda_{cg} = \lambda_{qg} = \lambda_{\gamma g} = 1$

For inclined ground, the permitted slope (angle ω below the horizontal) depends on soil angle of shearing resistance ϕ and the distance D_e between the foundation and the slope face:

- where $\phi \geq 0$ (drained analysis)
 v shall not be $> \phi$
- where $\phi = 0$ (undrained analysis)
 ω shall not be $> 45^\circ$

The ground inclination factors shall be:

- for $D_e \geq 2B$

$$\lambda_{cg} = \lambda_{qg} = \lambda_{\gamma g} = 1$$

- for $D_e < 2B$

$$\lambda_{cg} = 1 - \omega(1 - D_e/2B)/150$$

$$\lambda_{qg} = \lambda_{\gamma g} = (1 - \tan(\omega(1 - D_e/2B)))^2$$

Amend 16
Apr 2018

3.3.3 Local shear

For sands with relative densities less than 40% and clays having liquidity indices greater than 0.7, the bearing strength shall be evaluated using 0.67c for cohesion and $\tan^{-1}(0.67 \tan \phi)$ for the angle of shearing resistance.

COMMENT:

The formulae in Paragraph 3.3.2 assume a general shear failure of the soil but for the soils specified in this Paragraph a local shear failure is likely.

ARCHIVED

Figure 3: Bearing Strength Factors
Paragraphs 3.3.2 and 4.1.3

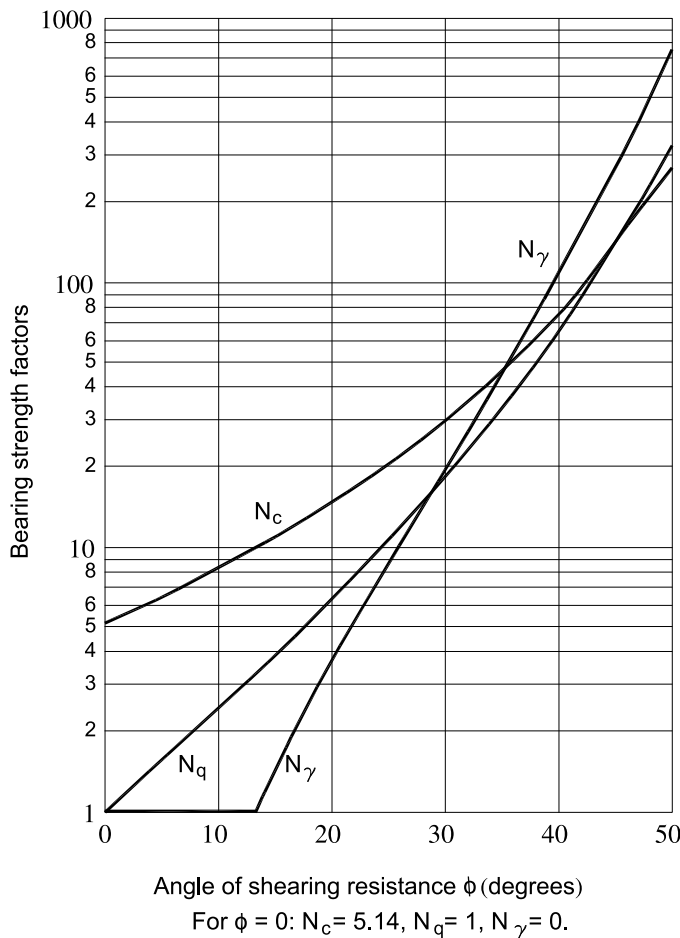

3.4 Ultimate limit state sliding resistance

3.4.1 When the loading is not normal to the foundation base, foundations shall be checked for failure by sliding.

3.4.2 The ultimate sliding resistance shall comprise the sum of the ultimate sliding strength between the base of the foundation and the ground, and any available passive earth pressure in the direction of sliding at the side of the foundation.

3.4.3 Passive earth pressure shall not be considered if:

- a) For foundations in clay soils, it is possible that the clay could shrink away from the vertical faces of the foundation, or

- b) The possibility exists that the soil in front of the foundation may be removed by erosion or by building or landscaping work in the future.

3.4.4 For drained conditions, the ultimate sliding strength shall be:

$$S = c'A' + V' \tan \delta'$$

The value of δ' shall be taken as the angle of shearing resistance (ϕ') of the foundation soil for cast-in-situ concrete foundations and $0.67\phi'$ for smooth precast foundations.

3.4.5 For undrained conditions, the ultimate sliding strength shall be:

$$S = A's_u$$

ARCHIVED

3.4.6 Design sliding resistance

The design horizontal load H shall not exceed the design sliding resistance, that is:

$$H \leq \Phi_{sl}S + \Phi_{pp} P_p$$

3.5 Strength reduction factors

3.5.1 *Strength reduction factors* to be applied to shallow foundation design shall be within the range given in Table 1.

The designer shall nominate in the design the *strength reduction factors* chosen along with substantiation as to why the values chosen are considered appropriate. The values chosen shall be to the approval of the *territorial authority*.

COMMENT:

The value of the *strength reduction factor* used in design will depend on the designer’s knowledge of the site and the investigations undertaken. As a guide the lower end of the range will generally be appropriate when a limited site investigation is undertaken, average geotechnical properties are used, published correlations are used to obtain design parameters or there will be minimal *construction* control. The upper end of the range will generally be appropriate when a comprehensive site investigation and laboratory testing is undertaken, geotechnical properties are chosen conservatively, site specific correlations are used for design parameters and there will be careful *construction* control.

4.0 Pile Foundations

4.0.1 The ultimate axial compressive pile strength for a single pile shall be determined using either or both of the following methods:

- a) Geotechnical calculation,
- b) Static load testing.

COMMENT:

Where piles are driven, a driving formula, such as the Hiley Formula, may provide a useful means of assessing the comparative strength of the individual piles at a particular site.

4.0.2 Using geotechnical calculation, the ultimate axial compressive pile strength is the sum of the ultimate pile point-bearing resistance and the shaft resistance.

4.0.3 When determined by static load testing, the ultimate axial compressive pile strength shall be taken as no more than that load which produces a penetration or pile settlement of 0.1 times the:

- a) *Nominal pile width* for driven piles,
- b) Bell diameter for belled piles,
- c) Estimated minimum bulb diameter for bulbed piles.

Suitable procedures for static load testing are described in AS 2159 Section 8, ASTM D1143 and BS 8004 Section 7.5.

4.0.4 The design pile vertical or lateral strength of a single pile or pile group shall be determined by multiplying the ultimate strength by the appropriate *strength reduction factor* (see Paragraph 4.7.1). The design strength shall be greater than the applied factored loads.

Table 1: Strength Reduction Factors for Shallow Foundation Design Paragraph 3.5.1	
Load combination	Strength reduction factor range
For bearing (Φ_{bc}) and passive earth pressure (Φ_{pp}):	
Load combinations involving earthquake overstrength	0.80 – 0.90
All other load combinations	0.45 – 0.60
For sliding (Φ_s):	
All load combinations, including earthquake overstrength	0.80 – 0.90

ARCHIVED

4.1 Ultimate vertical strength of single piles

4.1.1 Notation

- A_b area of pile base (m^2).
- B_G width (between pile extremities) of a pile group (m).
- C circumference of the pile shaft (m).
- D_b diameter of the pile base (m).
- D_s diameter of the pile shaft (m).
- H design horizontal load applied to the pile head (factored applied loads) (kN).
- H_u ultimate lateral strength of a pile (kN).
- K_o the coefficient of earth pressure at rest = $1 - \sin\phi'$ for loose sand and normally consolidated clay, and $(1 - \sin\phi')\sqrt{OCR}$ for over-consolidated soils.
- K_p coefficient of passive earth pressure = $(1 + \sin\phi')/(1 - \sin\phi')$.
- K_s factor that expresses the horizontal effective stress at the pile/soil interface in terms of the vertical effective stress (see Table 2).
- L length of the pile shaft (m).
- L_G length (between pile extremities) of a pile group (m).
- M design moment applied to the pile head (factored applied moments) (kNm).
- M_{ult} ultimate moment strength of the pile shaft (kNm).
- OCR over-consolidation ratio being the previous maximum effective stress/current effective stress.

- R_d relative density as measured in accordance with Test 4.2.3 of NZS 4402.
- V_1 ultimate strength of an individual pile in the group (kN).
- V_B ultimate strength of the block of soil enclosed within the pile group (kN).
- V_G ultimate strength of the group (kN).
- V_{bu} ultimate base resistance (kN).
- V_{su} ultimate shaft resistance (kN).
- V_u vertical pile strength (kN).
- W pile weight (part of the dead load) (kN).
- c_a the undrained adhesion (total stress) at the soil/shaft interface in a clay soil, or the adhesion at the boundary of a pile group = αs_u (kPa).
- c'_a drained (effective stress) adhesion at the soil/shaft interface in a cohesive soil, or the adhesion at the boundary of a pile group (kPa).
- f for a free head pile, the distance above the ground surface at which the horizontal shear is applied (= M/H); and for a restrained head pile, the distance above the ground surface at which the restraint is applied (m).
- f_o length of pile shaft assumed to be unsupported in cohesive soil = $1.5D_s$ (m).
- g_c, g_l, g_s position along the pile shaft at which yielding occurs for piles in over-consolidated clay, normally consolidated clay, and sand respectively (m).
- n number of piles in the group.

Table 2: Values of δ' and K_s for Pile Shafts
Paragraphs 4.1.1 and 4.1.4 b) and c)

Pile material	δ'	K_s	
		$R_d < 40\%$	$R_d > 40\%$
Steel	20°	0.5	1.0
Concrete	3 ϕ /4	1.0	2.0
Timber	2 ϕ /3	1.5	4.0

ARCHIVED

- q vertical stress in the soil at a depth equal to the base of the pile shaft, total stress for undrained analysis and effective stress for drained analysis (kPa).
- s_u undrained shear strength (kPa).
- Φ_{pc} strength reduction factor for pile strength (for both vertical and lateral strength) (see Paragraph 4.7.1).
- α adhesion factor (see Figure 5).
- γ unit weight of the soil in which the pile is embedded, chosen to give the total stresses for undrained loading in cohesive soil and effective stresses for drained loading (γ^l beneath the water table) (kN/m³).
- Γ γ when the water table is deeper than 2B beneath the underside of the foundation and γ^l when the water table is above this.
- δ^l drained angle of shearing resistance at the soil/shaft interface (see Table 2) (degrees).
- ϕ angle of shearing resistance (degrees).
- ϕ^l effective stress angle of shearing resistance (degrees).
- χ rate of increase in undrained shear strength with depth (kPa/m).
- $()_{average}$ the average value of the parameter in the brackets taken over the length of the pile shaft.

4.1.2 Vertical strength

The vertical pile strength is:

$$V_u = V_{su} + V_{bu}$$

4.1.3 Base resistance

The undrained base resistance of piles in cohesive soil is:

$$V_{bu} = (9s_u + q) A_b$$

The drained base resistance, when the soil is sufficiently uniform to be represented by single values of c^l , ϕ^l , s_u and γ for a distance of three pile shaft diameters above and below the pile base, shall be:

$$V_{bu} = (9c^l + q^l N_q + 0.6 D_b \Gamma N_\gamma) A_b$$

The values of N_q are taken from Figure 4 and N_γ from Figure 3.

4.1.4 Shaft resistance

- a) For undrained loading of piles in cohesive soils:

$$V_{su} = (c_a)_{average} CL$$

where $c_a = \alpha s_u$ and values for α are given in Figure 5 for both driven and bored piles.

- b) For drained loading of piles in cohesive soils:

$$V_{su} = \{ (c_a^l)_{average} + (\sigma_v^l K_o \tan \delta^l)_{average} \} CL$$

The value of δ^l is taken from Table 2.

- c) For drained loading of driven piles in cohesionless soils:

$$V_{su} = (\sigma_v^l K_s \tan \delta^l)_{average} CL$$

Values for K_s are given in Table 2.

4.2 Column action

4.2.1 Piles which stand unbraced in ground, water, or other material incapable of providing lateral support, shall be designed as columns.

4.2.2 For a column partly embedded in the ground, the effective length is dependent upon the position of end restraint, which in turn is dependent upon the nature of the ground. End restraint shall be assumed at a depth of no less than:

- 3 times the *nominal pile width* in very stiff soil. (For clays an undrained shear strength greater than or equal to 100 kPa, and for sands a relative density greater than or equal to 50% shall be regarded as very stiff soil.)
- 6 times the *nominal pile width* in firm soil. (For clays an undrained shear strength between 50 and 100 kPa, and for sands a relative density between 30 and 50% shall be regarded as stiff soil.)
- 9 times the *nominal pile width* in other soil conditions.

ARCHIVED

Figure 4: N_q Values for Pile Foundations
Paragraph 4.1.3

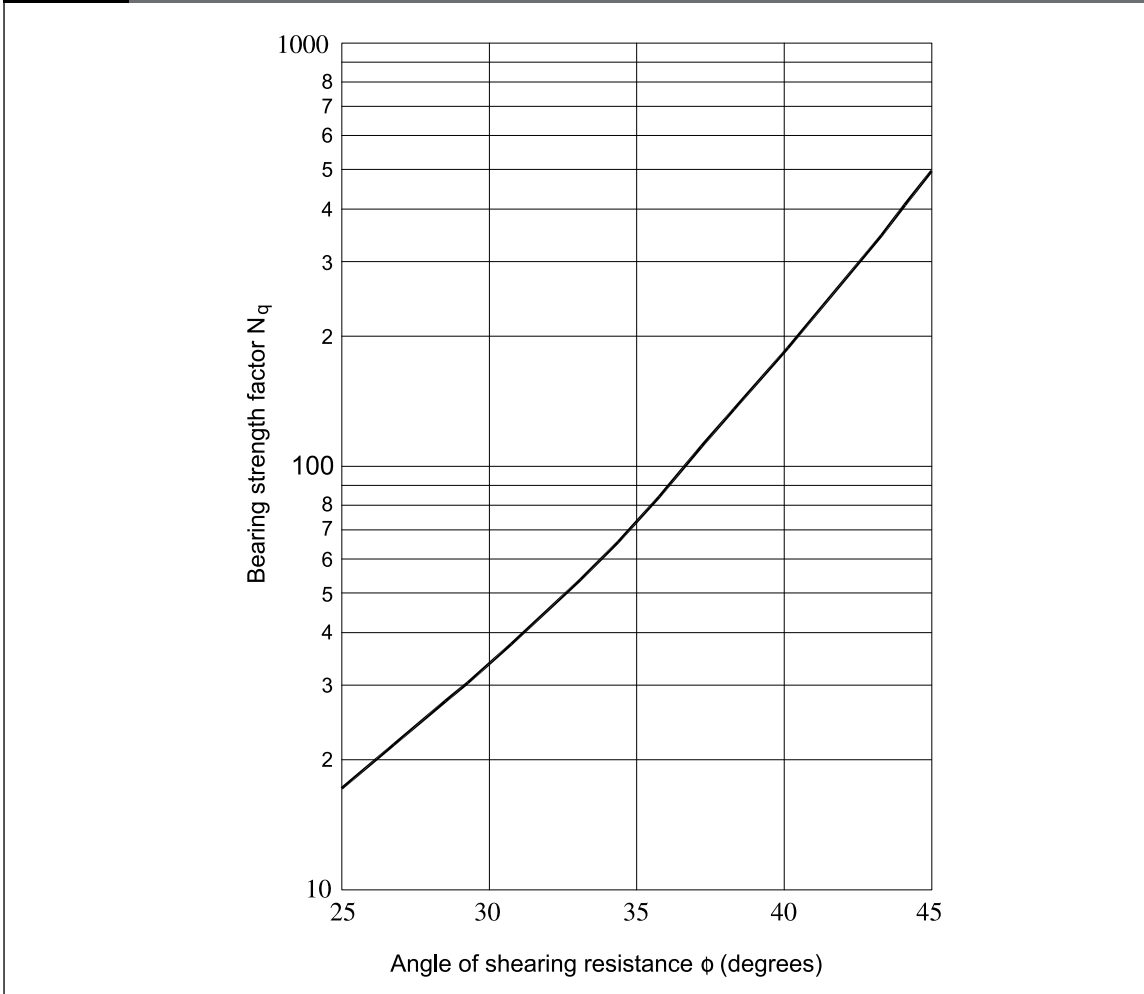
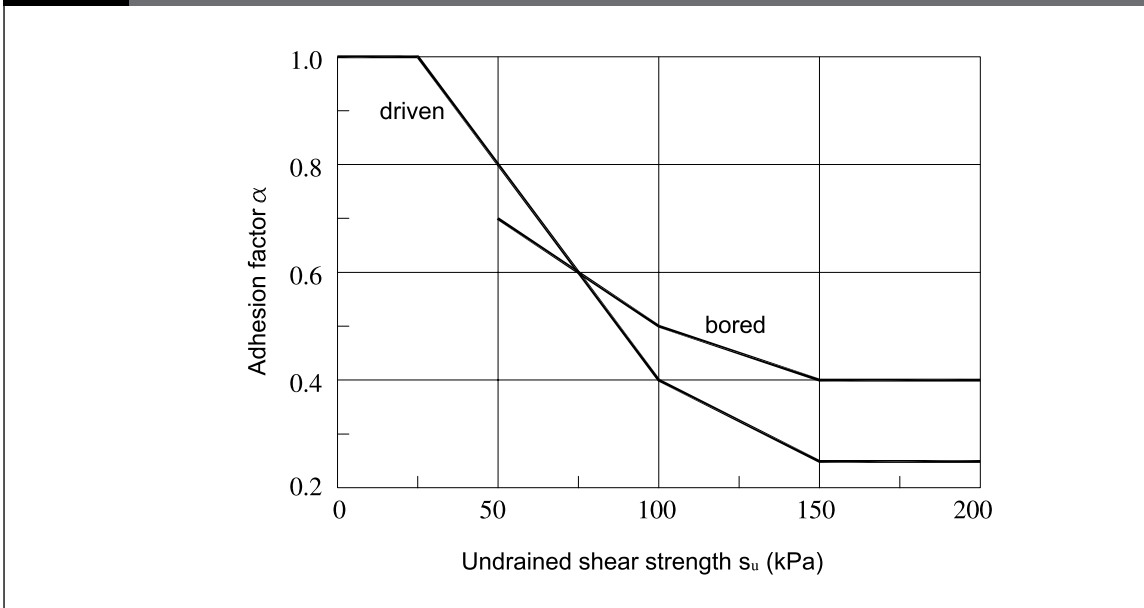

Figure 5: Adhesion Factor for Piles in Cohesive
Paragraphs 4.1.1 and 4.1.4 a)



ARCHIVED

$$H_u = 9s_u D_s \left[\sqrt{2[(f + L)^2 + (f + f_o)^2]} - (L + 2f + f_o) \right]$$

Amend 9
Sep 2001**4.3 Ultimate lateral strength of single piles**

4.3.1 In the following paragraphs the terms “free head” and “restrained head” pile are used. Free head piles are classified as short and long. Restrained head piles are classified as short, intermediate and long. These terms are explained as follows:

- a) A free head pile has no restriction against head rotation when lateral displacement occurs. For a short free head pile the magnitude of the maximum bending moment in the embedded shaft is less than the ultimate moment strength of the pile shaft, and the ultimate strength is controlled by the embedment length of the pile shaft. The strength of a long free head pile is controlled by the ultimate moment strength of the pile shaft and not by the embedded length.
- b) For a restrained head pile subject to lateral displacement, the head rotation is constrained at the pile head by a fixing moment. A short pile is one in which the head moment and the maximum pile shaft moment are less than the ultimate moment strength of the pile section. For an intermediate length restrained head pile the head moment is equal to the ultimate strength of the pile shaft and elsewhere the shaft moments are less than M_{ult} . For a long restrained head pile the head moment and the maximum pile shaft moment each have a magnitude of M_{ult} .

4.3.2 Undrained lateral strength of piles in cohesive soil having a constant undrained shear strength with depth**a) Free head piles**

- i) short free head piles

The ultimate lateral strength of a short free head pile is given by:

The location, measured from the ground surface, of the maximum pile shaft moment is:

$$g_c = \frac{H_u}{9s_u D_s} + f_o$$

The maximum moment in the pile shaft is:

$$M_{max} = H_u \left(f + f_o + \frac{H_u}{18s_u D_s} \right)$$

Amend 5
Jul 2001

If M_{max} is greater than M_{ult} the strength must be evaluated as for a long free head pile.

- ii) long free head piles

The ultimate lateral strength of a long free head pile

$$H_u = 3s_u D_s \left[\sqrt{9(f + f_o)^2 + \frac{2M_{ult}}{s_u D_s}} - 3(f + f_o) \right]$$

The location of the maximum pile shaft moment (M_{ult}) is obtained from the same equation as for the short pile.

b) Restrained head piles

- i) short restrained head piles

The ultimate lateral strength of a short restrained head pile is:

$$H_u = 9s_u D_s (L - f_o)$$

The pile head moment is:

$$M_{max} = 0.5H_u (L + 2f + f_o)$$

If M_{max} is greater than M_{ult} then the intermediate length case, ii) below, is appropriate.

ARCHIVED

- ii) intermediate restrained head piles

The ultimate lateral strength of an intermediate length restrained head pile is:

$$H_u = 9s_u D_s \left[\sqrt{(L + 2f + f_o)^2 + (L - f_o)^2 + \frac{4M_{ult}}{9s_u D_s}} - (L + 2f + f_o) \right]$$

The location, measured from the ground surface, of the maximum pile shaft moment is:

$$g_c = \frac{H_u}{9s_u D_s} + f_o$$

The pile shaft moment at this depth is:

$$M_{max} = H_u \left[\frac{H_u}{18s_u D_s} + f + f_o \right] - M_{ult}$$

If M_{max} calculated from this equation is greater than M_{ult} then the long case, iii) below, is appropriate.

- iii) long restrained head piles

The ultimate lateral strength of a long restrained head pile is:

$$H_u = 9s_u D_s \left[\sqrt{(f + f_o)^2 + \frac{4M_{ult}}{9s_u D_s}} - (f + f_o) \right]$$

The location of the maximum pile shaft (M_{ult}) is obtained from the same equation as for the intermediate length pile.

4.3.3 Undrained lateral strength of piles in normally consolidated cohesive soil

Normally consolidated cohesive soils have a linear increase in undrained shear strength with depth, starting with a value of zero at ground surface level.

COMMENT:

Only the long free head pile and intermediate and long restrained head piles are considered. Short piles are not normally used in such material.

The rate of increase in undrained shear strength with depth is denoted by χ (kPa/m).

- a) **Long free head pile**

The ultimate lateral strength of a long free head pile is obtained by solving:

$$H_u \left[\frac{2}{3} \sqrt{\frac{2H_u}{9D_s \chi}} + f \right] - M_{ult} = 0$$

The location, measured from the ground surface, of the maximum pile shaft moment (M_{ult}) is:

$$g_l = \sqrt{\frac{2H_u}{9D_s \chi}}$$

- b) **Restrained head pile**

- i) intermediate restrained head piles

The ultimate lateral strength of an intermediate length restrained head pile is:

$$H_u = \frac{3D_s L^3 \chi}{2(f + L)} + \frac{M_{ult}}{f + L}$$

The location of the maximum pile shaft moment (M_{ult}) is obtained from the same equation as for the long free head pile.

The pile shaft moment at this depth is:

$$M_{max} = H_u \left[\frac{2}{3} \sqrt{\frac{2H_u}{9D_s \chi}} + f \right] - M_{ult}$$

If M_{max} calculated from this equation is greater than M_{ult} then the long case, ii) below, is appropriate.

- ii) long restrained head piles

The ultimate lateral strength of a long restrained head pile is obtained by solving:

ARCHIVED

b) **Restrained head piles**

i) short restrained head piles

The ultimate lateral strength of a short restrained head pile is:

$$H_u = 1.5K_p D_s L^2 \gamma$$

The magnitude of the maximum pile head moment is:

$$M_{\max} = H_u \left(\frac{2}{3}L + f \right)$$

If M_{\max} is greater than M_{ult} then the intermediate length case, ii) below, is appropriate.

ii) intermediate restrained head piles

The ultimate lateral strength of an intermediate length restrained head pile is:

$$H_u = \frac{K_p D_s L^3 \gamma}{2(f + L)} + \frac{M_{ult}}{f + L}$$

The location, measured from the ground surface, of the maximum pile shaft moment is:

$$g_s = \sqrt{\frac{2H_u}{3K_p D_s \gamma}}$$

The pile shaft moment at this depth is:

$$M_{\max} = H_u \left[\frac{2}{3} \sqrt{\frac{2H_u}{3K_p D_s \gamma}} + f \right] - M_{ult}$$

If M_{\max} calculated from this equation is greater than M_{ult} then the long case, iii) below, is appropriate.

$$H_u \left[\frac{2}{3} \sqrt{\frac{2H_u}{9D_s \chi}} + f \right] - 2M_{ult} = 0$$

The location of the maximum pile shaft moment is obtained from the same equation as for the long free head pile.

4.3.4 Drained lateral strength of piles in cohesionless soil

a) **Free head piles**

i) short free head piles

The ultimate lateral strength of a short free head pile is:

$$H_u = \frac{K_p D_s L^3 \gamma}{2(f + L)}$$

The location, measured from the ground surface, of the maximum pile shaft moment is:

$$g_s = \sqrt{\frac{2H_u}{3K_p \gamma D_s}}$$

The maximum pile shaft moment is:

$$M_{\max} = H_u \left[\frac{2}{3} \sqrt{\frac{2H_u}{3K_p D_s \gamma}} + f \right]$$

ii) long free head piles

The ultimate lateral strength of a long free head pile is obtained by solving the following equation:

$$H_u \left[\frac{2}{3} \sqrt{\frac{2H_u}{3K_p D_s \gamma}} + f \right] - M_{ult} = 0$$

The location of the maximum pile shaft moment (M_{ult}) is obtained from the same equation as for the short pile.

Amend 16
Apr 2018

ARCHIVED

iii) long restrained head piles

The ultimate lateral strength of a long restrained head pile is obtained by solving:

$$H_u \left[\frac{2}{3} \sqrt{\frac{2H_u}{3K_p D_s \gamma}} + f \right] - 2M_{ult} = 0$$

The location of the maximum pile shaft moment is obtained from the same equation as is used for the intermediate length case.

4.4 Pile groups

4.4.1 Ultimate vertical strength of pile groups

The undrained vertical strength of a pile group considered as a single block in a cohesive soil is:

$$V_B = (9s_u + q) B_G L_G + 2 (B_G + L_G) L (c_a)_{average}$$

The drained strength of a pile group considered as a single block of soil is given by:

$$V_B = (c^l + q^l N_q + 0.6 B_G \Gamma N_\gamma) B_G L_G + 2 (B_G + L_G) L \{ (c_a^l)_{average} + (\sigma_v^l K_o \tan \delta^l)_{average} \}$$

The ultimate vertical strength of the group is determined from:

$$\frac{1}{V_G^2} = \frac{1}{n^2 V_1^2} + \frac{1}{V_B^2}$$

4.4.2 If only part of an embedded friction pile length is in satisfactory material, the surface area calculated as providing frictional resistance shall be limited to the surface areas in contact with that material.

4.5 Downdrag

4.5.1 Downdrag may be generated when a pile shaft passes through a compressible soil layer. Downdrag shall be considered as dead load applied to the parts of the pile below the compressible layer. It shall be added to the imposed loadings and factored accordingly.

4.6 Ultimate lateral strength of pile groups

4.6.1 If piles are spaced at centre to centre intervals of less than 4.0 times the *nominal pile width*, the ultimate lateral pile strength shall be reduced. The reduced value shall be calculated as a percentage of the ultimate lateral pile strength for an isolated pile by linear interpolation between the two values given in Table 3.

4.7 Strength reduction factors

4.7.1 *Strength reduction factors* for design of ultimate vertical and lateral strengths in pile foundations shall be within the range given in Table 4.

The designer shall nominate in the design the *strength reduction factors* chosen along with substantiation as to why the values chosen are considered appropriate. The values chosen shall be to the approval of the *territorial authority*.

COMMENT:

The value of the *strength reduction factor* used in design will depend on the designer's knowledge of the site and the investigations undertaken. As a guide the lower end of the range will generally be appropriate when a limited site investigation is undertaken, average geotechnical properties are used, published correlations are used to obtain design parameters or there will be minimal *construction* control. The upper end of the range will generally be appropriate when a comprehensive site investigation and laboratory testing is undertaken, geotechnical properties are chosen conservatively, site specific correlations are used for design parameters and there will be careful *construction* control.

5.0 Pile Types

5.1 Concrete piles

5.1.1 Precast concrete piles, including prestressed piles, shall withstand without damage or significant cracking, the stresses arising from manufacture, handling and transportation, in addition to those arising from driving and imposed loadings.

ARCHIVED

5.1.2 Belled bases of cast-in-situ concrete piles shall be no less than 100 mm thick at the edge of the required base and, unless the bell is reinforced, the conical surfaces shall slope at an angle from the horizontal of no less than 60°.

5.2 Steel piles

5.2.1 The design of steel piles shall be based on the nett steel section after deducting an appropriate thickness for future loss by corrosion.

This verification method does not describe a means of determining the amount of corrosion and proposals must be submitted to the territorial authority for approval.

COMMENT:

The amount deducted needs to take account of the aggressiveness of the soil. Further guidance can be found in AS 2159 Section 6.3 or the HERA Design and Construction Bulletin No 46.

5.2.2 Allowance for corrosion loss need not be made for steel encased in concrete provided cover to the steel is no less than:

- a) 30 mm for prestressed concrete,
- b) 50 mm for precast concrete,
- c) 75 mm for cast-in-situ concrete.

5.3 Timber piles

5.3.1 Timber piles shall comply with NZS 3605 or NZS 3603 as applicable, and be naturally durable or treated to the appropriate hazard level as recommended by NZS 3640.

5.3.1.1 NZS 3605 shall be subject to the following modification:

Clause 4.2.4.1 after “limitations for” add the word “verified”

Amend 9
Sep 2010

Table 3: Closely Spaced Piles, Design Lateral Resistance
Paragraph 4.6.1

Pile spacing	% of isolated pile lateral resistance
4.0 x nominal pile width	100
1.0 x nominal pile width (palisade type wall)	25

Table 4: Strength Reduction Factors for Deep Foundation Design
Paragraph 4.7.1

Method of assessment of ultimate geotechnical strength for load combinations not involving earthquake overstrength	Range of values of Φ_{pc}
Static load testing to failure	0.65 – 0.85
Static proof (not to failure) load testing	0.70 – 0.90
Static analysis using CPT (Cone Penetrometer Test) data	0.45 – 0.65
Static analysis using SPT (Standard Penetrometer Test) data in cohesionless soils	0.40 – 0.55
Static analysis using laboratory data for cohesive soils	0.45 – 0.55
Method of assessment of ultimate geotechnical strength for load combinations including earthquake overstrength	0.80 – 0.90

ARCHIVED

Appendix A (Informative)

ARCHIVED

A1.0 Site Investigation

A1.1 General

A1.1.1 No specific site investigation procedures are given in this document. The following information is provided for guidance only.

A1.1.2 The ground conditions at the *building* site should be investigated to the extent considered necessary, by a person with appropriate expertise and experience, to provide essential site data for design of the proposed *building*. Both preliminary and detailed investigations may need to be undertaken.

A1.2 Preliminary investigation

A1.2.1 The preliminary site assessment may include investigation of:

- a) General land form, geology and any conditions likely to facilitate landslip, soil creep, shrinkage and expansion, or subsidence.
- b) Information available from records of previous *constructions*, excavations, fillings, *drains* and concealed works, on and adjacent to the site.
- c) History and behaviour of neighbouring *buildings* and details of their foundation types, depths and loadings.
- d) Potential for flooding (see also NZBC E1) and seasonal changes of soil characteristics.
- e) Seasonal, tidal or other natural groundwater changes.
- f) Presence of corrosive soil, groundwater and effluents (see also F1/VM1).

A1.3 Detailed investigation

A1.3.1 Detailed investigation may include:

- a) Test bores and excavations.
- b) Visual inspection.
- c) Laboratory and field testing of soil and rock samples.
- d) Advice from other people with relevant expertise.

A1.4 Recording information

A1.4.1 The description of the foundation material should be recorded. A suitable method for describing soil and rock is contained in "Guidelines for the field description of soils and rocks in engineering use" published by the New Zealand Geotechnical Society.

A1.4.2 The site investigation record should include a site plan showing the locations of the test bores and excavations.

Appendix B (Informative) **ARCHIVED**

B1.0 Serviceability Limit State Deformations (Settlement)

B1.0.1 No specific method is given for determining foundation settlement. The following information is provided for guidance only.

B1.0.2 Foundation design should limit the probable maximum differential settlement over a horizontal distance of 6 m to no more than 25 mm under serviceability limit state load combinations of AS/NZS 1170 Part 0, unless the structure is specifically designed to prevent damage under a greater settlement.

B1.0.3 The basis for analysing settlement should be stated in the design. The analysis shall pay due consideration to:

- a) Size, shape and depth of the foundations,
- b) Proximity and influence of proposed and existing foundations,
- c) Variability of the ground,
- d) The presence of compressive or expansive materials,
- e) Rate of consolidation,
- f) Groundwater level,
- g) Extent of fill placed and ground removed when constructing the foundation, and
- h) Likelihood of liquefaction, internal erosion, soil collapse or other special feature.

Amend 8
Dec 2008

Appendix C (Informative) Design Example – Retaining Wall Foundation

C1.0 Description of Wall, Limit States and Soil Properties

A gravity retaining wall backfilled with dry sand and founded on clay. In addition to static loading the effect of a horizontal earthquake acceleration of 0.20g is considered (there is no vertical acceleration component to the earthquake). The additional active thrust generated by the earthquake loading is assumed to act 0.6 times the height of the wall above foundation level. The proportions of the wall and the various soil properties are given in Figure C1.

There are six ultimate limit states to be considered:

- 1st Short term bearing capacity failure of the foundation beneath the wall,
- 2nd Short term sliding at foundation level,
- 3rd Short term bearing capacity failure under earthquake loading,
- 4th Short term sliding under earthquake loading,
- 5th Long term bearing capacity failure of the foundation beneath the wall,
- 6th Long term sliding at foundation level.

Short term analysis (both for the initial static loading of the foundation and the earthquake loading) is performed in terms of total stress and uses the undrained shear strength (s_u) of the clay whilst the long term analysis is done using effective stresses and uses the strength parameters c' and ϕ' for the clay (see Paragraph 2.0.6). The thrust from the sand backfill is based on effective stresses and is the same for all cases (see Paragraph 2.0.7).

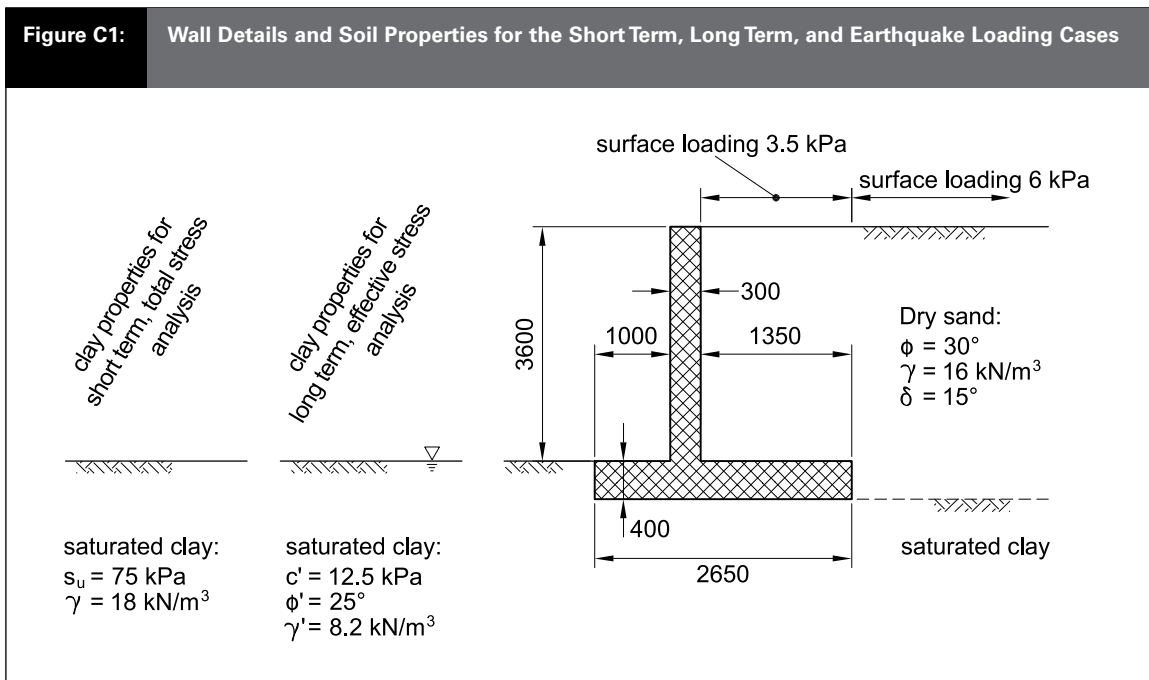

ARCHIVED

C2.0 Earth Pressure Coefficients

Active pressure coefficient for the sand backfill ($\delta = \phi/2$)	0.30
Active pressure coefficient for the sand backfill under EQ (0.20g)	0.45
Passive earth pressure coefficient for clay ($\phi = 25^\circ$ and $\delta = \phi/2$)	3.50

C3.0 Load Factors and Strength Reduction Factors

Load factor for dead loads that improve stability	1.0
Load factor for static active earth thrusts	1.6
Load factor for active earth thrusts under earthquake	1.0
<i>Strength reduction factor</i> for static and EQ bearing failure (Φ_{bc})	0.45
<i>Strength reduction factor</i> for passive earth pressure (Φ_{pp})	0.45
<i>Strength reduction factor</i> for static and EQ sliding failure (Φ_{sl})	0.80

C4.0 Notation

The notation in Figure C2 is used to identify the weights and active thrusts on the wall, whilst in Figure C3 the actions on the foundation are shown.

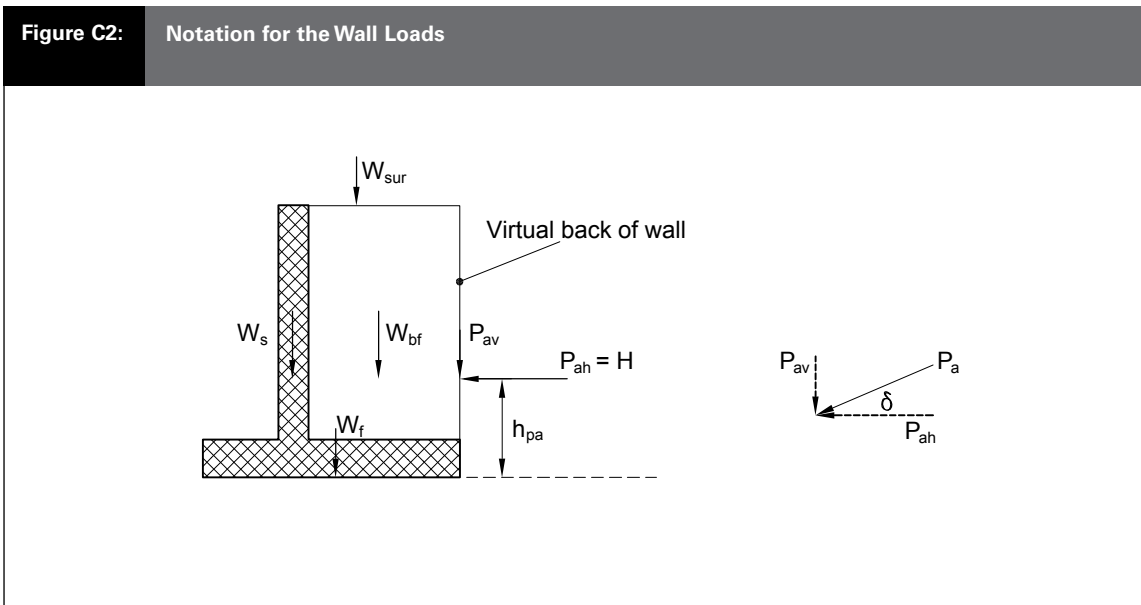

ARCHIVED

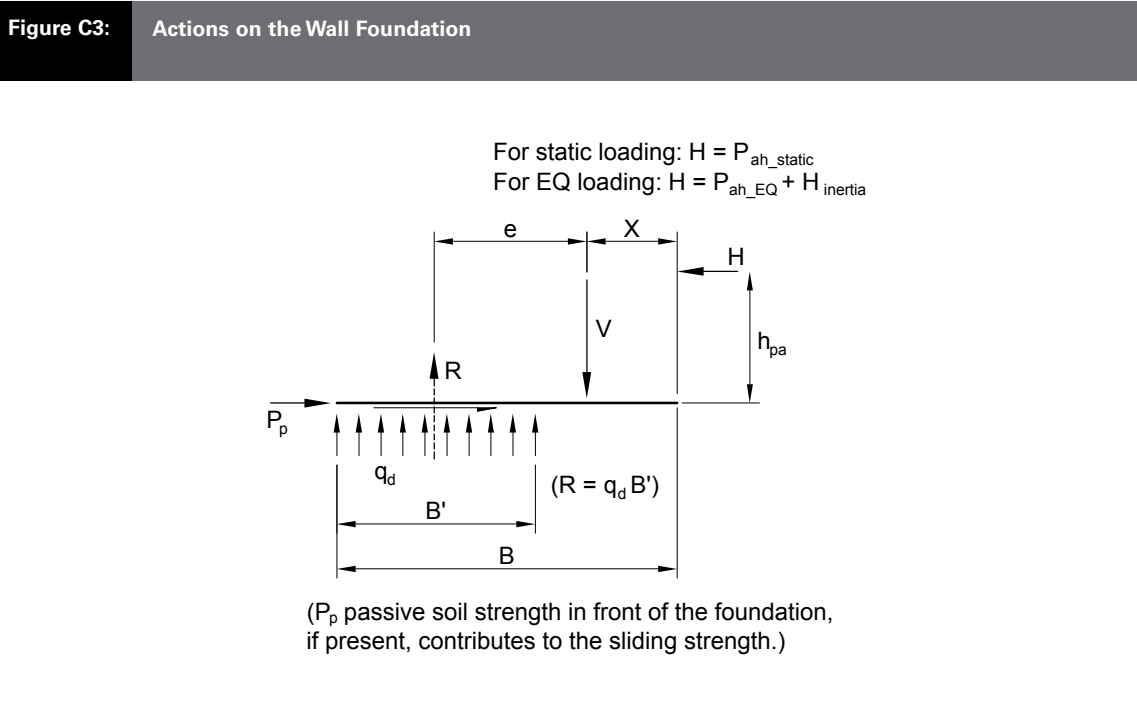

C5.0 Loadings

C5.1 Active thrusts

Unfactored active thrusts:

Static active thrust per metre from backfill (kN/m)	0.3 x 16 x 4 ² /2	=	38.40
Static active thrust per metre from surcharge	0.3 x 6 x 4	=	7.20
Total static active thrust per metre of wall	38.4 + 7.2	=	45.60
EQ active thrust per metre from backfill	0.45 x 16 x 4 ² /2	=	57.60
EQ active thrust per metre from surcharge	0.45 x 6 x 4	=	10.80
Total EQ active thrust per metre of wall	57.60 + 10.80	=	68.40
Difference between static and EQ active thrust from backfill	57.60 - 38.40	=	19.20

Factor static active thrusts and find location of resultant:

Factored static active thrust from backfill (kN/m)	38.40 x 1.6	=	61.44
Factored static active thrust from surcharge	7.2 x 1.6	=	11.52
Total factored active thrust per metre of wall	61.44 + 11.52	=	72.96

Take moments about heel to get location of active thrust (m)

$$h_{pa_static} = (38.40/3.0 + 7.20 \times 0.5) \times 4/45.60 = 1.44$$

Horizontal component of static thrust (kN/m) $H = P_{ah_static} = 72.96 \times \cos 15 = 70.47$

Vertical component of static thrust (kN/m) $P_{av_static} = 72.96 \times \sin 15 = 18.88$

ARCHIVED

Factor EQ active thrusts and find location of resultant:

Factored EQ active thrust. $57.60 \times 1 + 10.80 \times 1 = 68.40$

Take moments about heel to get location of active thrust (m)

$$h_{pa_EQ} = (38.40/3.0 + 10.80 \times 0.5 + 19.20 \times 0.6) \times 4/68.40 = 1.74$$

Horizontal component of EQ thrust (kN/m) $P_{ah_EQ} = 68.40 \times \cos 15 = 66.07$

Vertical component of EQ thrust (kN/m) $P_{av_EQ} = 68.40 \times \sin 15 = 17.70$

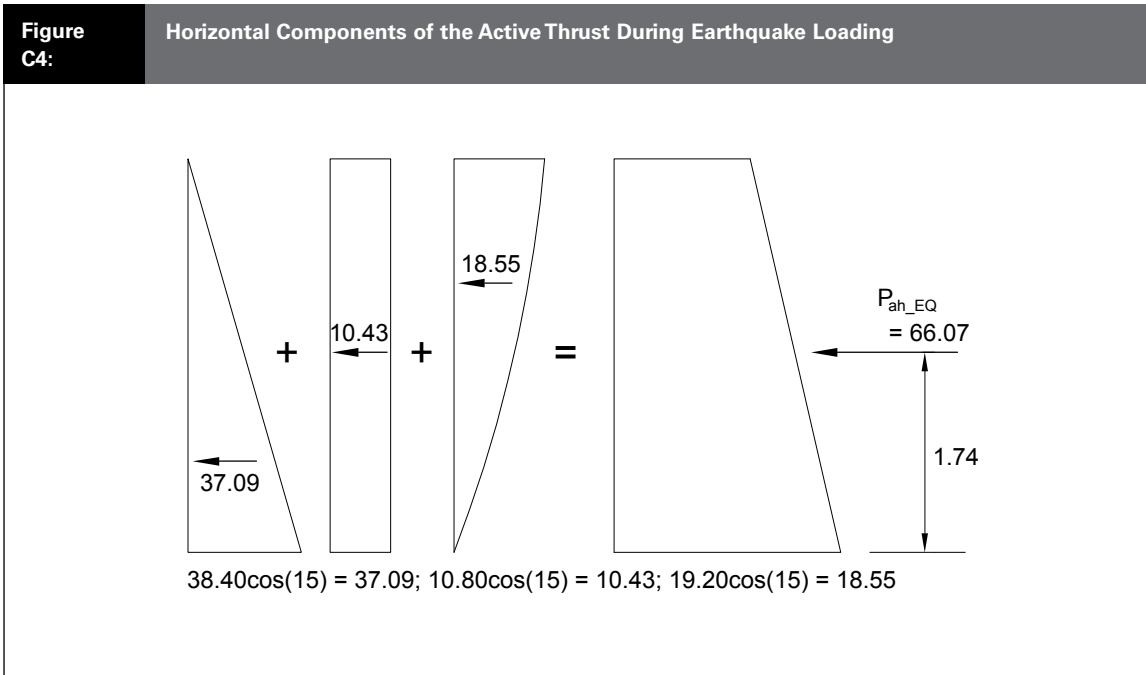

C5.2 Weights (load factor 1.0) and resultant vertical forces on the wall

Weight of wall stem. $W_s = 3.6 \times 0.3 \times 25 = 27.00$

Weight of wall foundation $W_f = 2.65 \times 0.4 \times 25 = 26.50$

Weight of backfill above the heel of the wall $W_{bf} = 3.6 \times 1.35 \times 16 = 77.76$

Vertical force from surcharge above heel. $W_{sur} = 3.5 \times 1.35 = 4.73$

Static vertical force on foundation (kN/m)

$$V = V_{static} = 18.88 + 27.00 + 26.50 + 77.76 + 4.73 = 154.87$$

EQ vertical force on foundation ($k_h = 0.2$ and $k_v = 0$) (kN/m)

$$V = V_{EQ} = 17.71 + 27.00 + 26.50 + 77.76 + 4.73 = 153.69$$

ARCHIVED

C5.3 Horizontal forces applied to the foundation

For the first, second, fifth and sixth ultimate limit states the horizontal force is:

$$H = P_{ah_static} = 70.47 \text{ kN/metre length of wall}$$

For the third and fourth ultimate limit states the inertia of the wall is added to the active thrust to determine H:

Horizontal inertia force on the weight of the wall stem (W_s)	27.00×0.20	=	5.40
Horizontal inertia force on the weight of the wall foundation (W_f)	26.50×0.20	=	5.30
Horizontal inertia force on the weight of fill over heel (W_{bf})	77.76×0.20	=	15.55
Horizontal inertia force on the surcharge over heel (W_{sur})	4.73×0.20	=	0.95

$$H_{inertia} = 5.40 + 5.30 + 15.55 + 0.95 = 27.20$$

Take moments about heel to get location of resultant inertia force (m):

$$h_{inertia} = [(15.55 + 5.40) \times (0.4 + 3.6/2) + 5.30 \times 0.2 + 0.94 \times 4] / 27.20 = 1.87$$

$$H_{EQ} = P_{ah_EQ} + H_{inertia} = 66.07 + 27.20 = 93.27 \text{ kN/metre of wall}$$

The weights of the various components of the wall and the horizontal inertia forces generated by the earthquake horizontal acceleration of 0.20g are given in Figure C5.

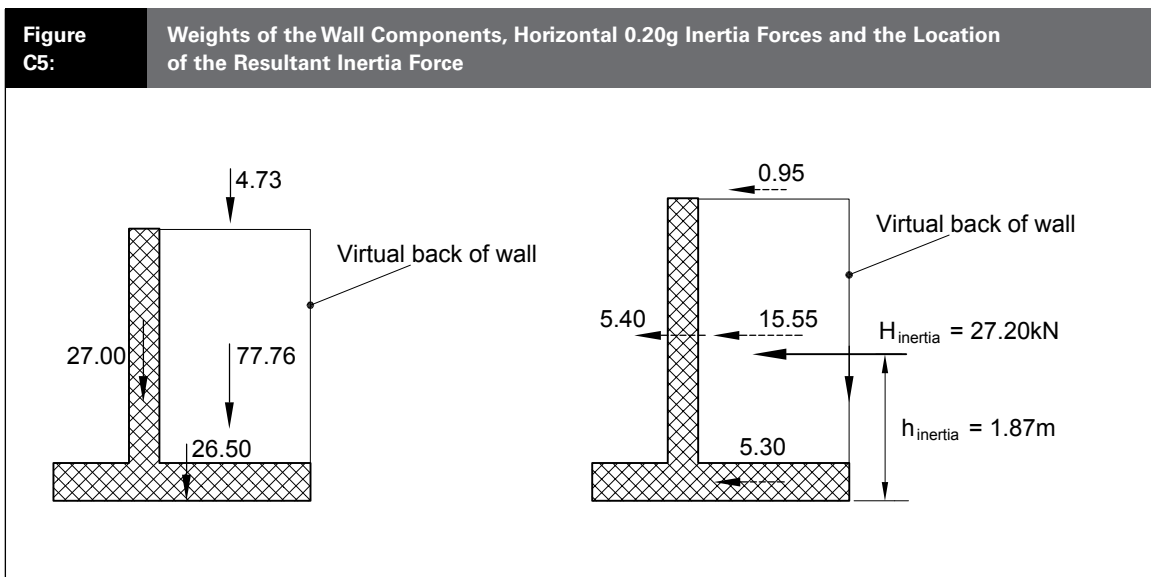

C6.0 Surcharge Pressures at Toe

Total stress surcharge pressure in front of wall (kPa) $q = \gamma_{clay} D_f = 18 \times 0.4 = 7.2$

Effective stress surcharge pressure in front of wall (kPa) $q' = \gamma'_{clay} D_f = 8.2 \times 0.4 = 3.3$

ARCHIVED

C7.0 First Ultimate Limit State (short term static foundation bearing failure)

Find X (location of V) by taking moments about heel.

Moment of the vertical forces:

$$(77.76 \times 1.35/2 + 4.73 \times 1.35/2 + 27.00 \times (1.35 + 0.15) + 26.50 \times 2.65/2) = 131.29$$

$$X = 131.29/154.87 = 0.848$$

Eccentricity: $e = 70.47 \times 1.44/154.87 = 0.655$

$$B^1 = 2 \times (0.848 + 0.655) = 3.01$$

$$B^2 = 2 \times (2.65 - 0.848 - 0.655) = 2.29$$

B^l is the smaller of B^1 and B^2 :

$B^l = 2.29$ (Distance from R to foundation edge = $B^l/2 = 1.15 > B/6$. . . ok (Paragraph 3.1.4))

Design bearing pressure: $q_d = V/B^l = 154.87/2.29 = 67.6$ kPa

Determine ultimate bearing strength $q_u = s_u \lambda_{cs} \lambda_{cd} \lambda_{ci} \lambda_{cg} N_c + \lambda_{qg} q$

For this case $\phi = 0$, so $N_c = 5.14$. λ_{cs} shall be taken as 1.0 as foundation is assumed to be long compared to its width. Also $\lambda_{cg} = \lambda_{qg} = 1.0$ as the foundation is horizontal. Thus we need only to evaluate λ_{cd} and λ_{ci} .

$$\lambda_{cd} = 1 + 0.4 \times D_f/B^l = 1 + 0.4 \times 0.4/2.29 = 1.07$$

$$\lambda_{ci} = 0.5(1 + \alpha(1 - H/B^l s_{u,i})) = 0.5 \times (1 + \alpha(1 - 70.47/2.29 \times 75)) = 0.88$$

$$q_u = s_u N_c \lambda_{cd} \lambda_{ci} + q = 75 \times 5.14 \times 1.07 \times 0.88 + 7.2 = 370.19$$

$$q_{dbs} = q_u \Phi_{bc} = 370.19 \times 0.45 = 166.6 \qquad q_d = 67.6 \qquad \text{Thus OK as } q_{dbs} > q_d$$

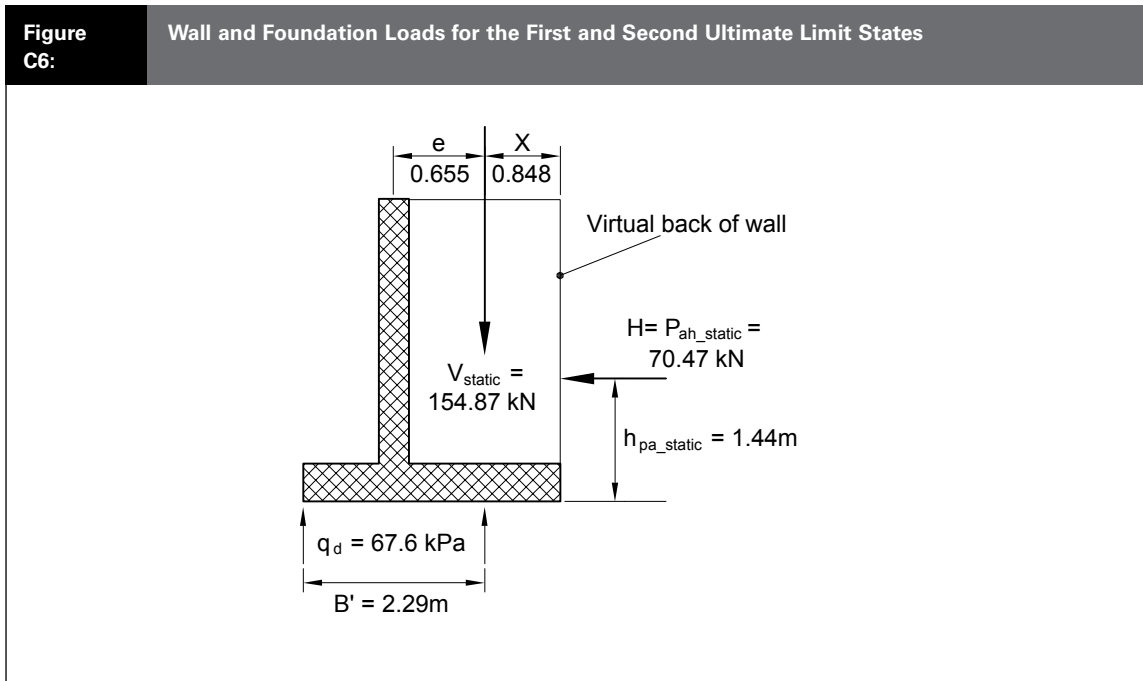

ARCHIVED**C8.0 Second Ultimate Limit State (short term static foundation sliding failure)**

The design sliding resistance is derived from the shear strength on the base and the passive resistance from the clay in front of the embedded part.

Ultimate shear strength: $S = s_u B' = 75 \times 2.29 = 171.75$

Passive resistance: $P_p = 2 s_u T_f + 0.5 \gamma_{\text{clay}} T_f^2$ where T_f is the foundation thickness
 $= 2 \times 75 \times 0.4 + 0.5 \times 18 \times 0.4^2 = 61.44$

Design sliding resistance: $S\Phi_{sl} + P_p\Phi_{pp} = 171.75 \times 0.8 + 61.44 \times 0.45 = 165.1$

$$H = 70.5$$

Thus OK as $S\Phi_{sl} + P_p\Phi_{pp} > H$

C9.0 Third Ultimate Limit State (short term foundation bearing failure under EQ)

Find X (location of V) by taking moments of vertical forces about heel.

Moment, as for the first ultimate limit state = 131.29

$$X = 131.29/153.69 = 0.854$$

To get eccentricity we need to add the moment of the horizontal inertia forces to that of the lateral thrust from the backfill:

$$e = (66.07 \times 1.74 + 27.20 \times 1.87)/153.69 = 1.079$$

$$B'1 = 2 \times (0.854 + 1.079) = 3.87$$

$$B'2 = 2 \times (2.65 - 0.854 - 1.079) = 1.43$$

B' is the smaller of $B'1$ and $B'2$:

$$B' = 1.43 \text{ (Distance from R to foundation edge} = B'/2 = 0.72 > B/6 \text{ } \therefore \text{ ok (Paragraph 3.1.4))}$$

$$\text{Design bearing pressure: } q_d = V/B' = 153.69/1.43 = 107.46 \text{ kPa}$$

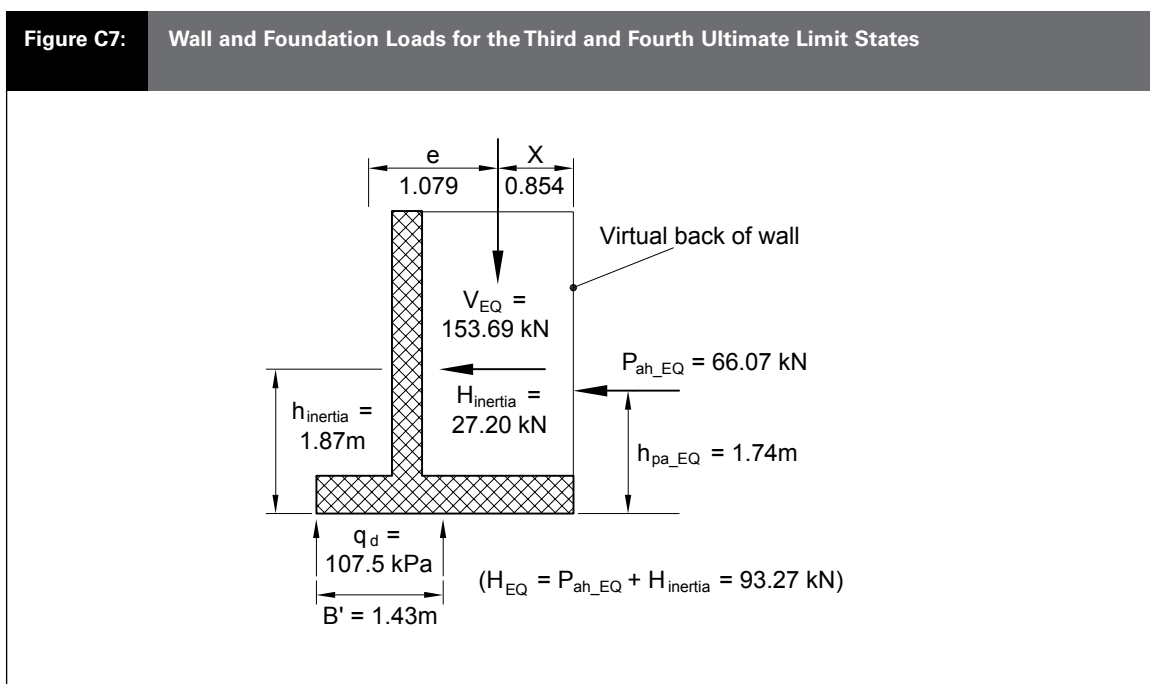

ARCHIVED

Determine ultimate bearing strength:

For this case $\phi = 0$, so $N_c = 5.14$. λ_{cs} shall be taken as 1.0 as foundation is assumed to be long compared to its width. Also $\lambda_{cg} = \lambda_{qg} = 1.0$ as the foundation is horizontal. Thus we need only to evaluate λ_{cd} and λ_{ci} .

$$\lambda_{cd} = 1 + 0.4 \times D_f/B' = 1 + 0.4 \times 0.4/1.43 = 1.11$$

$$\lambda_{ci} = 0.5(1 + \sqrt{(1 - H/B's_u)}) = 0.5 \times (1 + \sqrt{(1 - 93.29/1.43 \times 75)}) = 0.68$$

$$q_u = s_u N_c \lambda_{cd} \lambda_{ci} + q = 75 \times 5.14 \times 1.11 \times 0.68 + 7.2 = 298.17$$

$$d_{bs} = q_u \Phi_{bc} = 298.17 \times 0.45 = 134.2$$

$$q_d = 107.5$$

Thus OK as $q_{dbs} > q_d$

C10.0 Fourth Ultimate Limit State (short term foundation sliding failure under EQ)

The design sliding resistance is derived from the shear strength on the base and the passive resistance from the clay in front of the embedded part.

Ultimate shear strength: $S = s_u B' = 75 \times 1.43 = 107.25$

Passive resistance: $P_p = 2 s_u T_f + 0.5 \gamma_{clay} T_f^2 = 2 \times 75 \times 0.4 + 0.5 \times 18 \times 0.4^2 = 61.44$

Design sliding resistance: $S\Phi_{sl} + P_p\Phi_{pp} = 107.25 \times 0.8 + 61.44 \times 0.45 = 113.5$

$$H = 93.3$$

Thus OK as $S\Phi_{sl} + P_p\Phi_{pp} > H$

C11.0 Fifth Ultimate Limit State (long term foundation bearing failure)

For this case we work in terms of effective stress.

The strength parameters for the clay become: $c^l = 12.5$ kPa and $\phi^l = 25^\circ$. Furthermore the water table is at the ground surface in front of the wall so the buoyant density ($18 - 9.81 = 8.2$ kN/m³) controls the effective stresses.

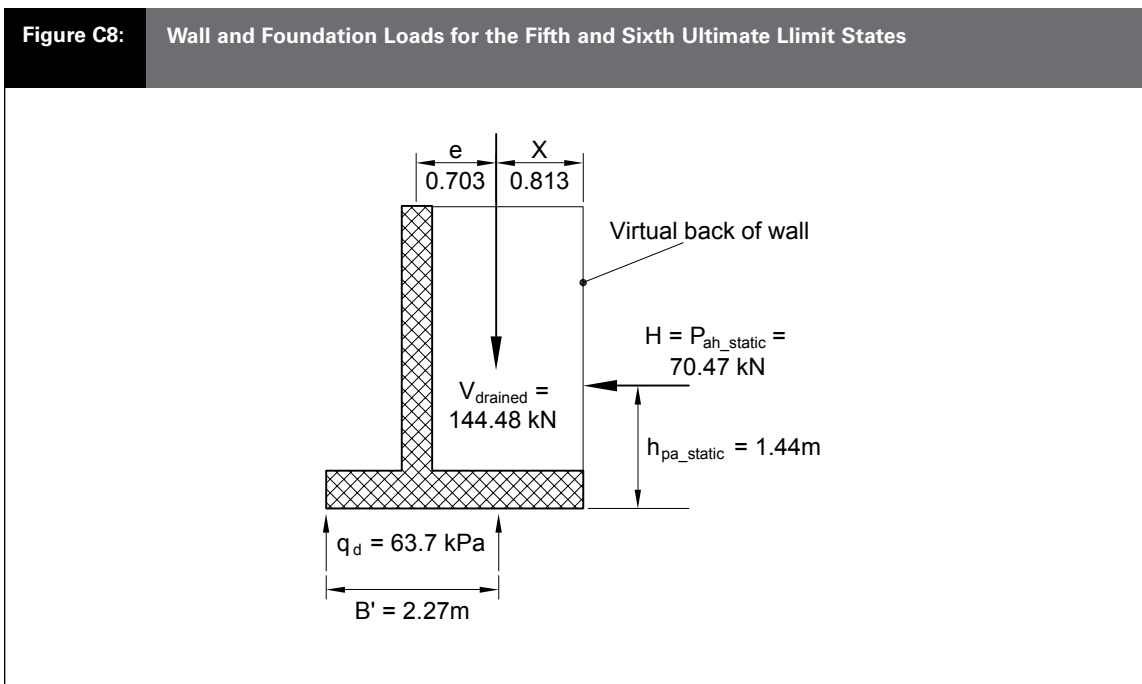

ARCHIVED

In addition there is a small positive water pressure acting on the underside of the wall which reduces the vertical load applied to the foundation.

$$u = 0.4 \times 9.81 = 3.92 \text{ and } V_{\text{drained}} = 154.87 - 3.92 \times 2.65 = 144.48$$

This has the effect of changing slightly X and e , hence B^l and q_d . We have from the first ultimate limit state the moment about the heel of the wall of the vertical forces = 131.29 kNm per metre length of the wall, so:

$$X = (131.29 - 3.92 \times 2.65 \times 2.65/2)/144.48 = 0.813$$

$$\text{Eccentricity of load: } e = 70.47 \times 1.44/144.48 = 0.703$$

$$B^l = 2 \times (2.65 - 0.813 - 0.703) = 2.27$$

$$\text{Design bearing pressure: } q_d = V_{\text{drained}}/B^l = 144.5/2.27 = 63.7 \text{ kPa}$$

For ϕ equal to 25° the bearing capacity factors are: $N_c = 21$, $N_q = 11$ and $N_\gamma = 9$.

Determine ultimate bearing strength:

$$q_{u,\text{drained}} = c^l \lambda_{cs} \lambda_{cd} \lambda_{ci} \lambda_{cg} N_c + q^l \lambda_{qs} \lambda_{qd} \lambda_{qi} \lambda_{qg} N_q + 0.5 B^l \gamma^l \lambda_{\gamma s} \lambda_{\gamma d} \lambda_{\gamma i} \lambda_{\gamma g} N_\gamma$$

Shape factors λ_{cs} , λ_{qs} and $\lambda_{\gamma s}$ shall be taken as 1.0 as foundation is assumed to be long compared to its width. Also ground inclination factors λ_{cg} , λ_{qg} and $\lambda_{\gamma g} = 1.0$ as the foundation is horizontal. Thus we need only to evaluate depth and load inclination factors.

Depth factors:

$$\lambda_{qd} = 1 + 2 \tan \phi^l (1 - \sin \phi^l)^2 (D_f/B) = 1 + 2 \tan(25)(1 - \sin(25))^2 (0.4/2.27) = 1.05$$

$$\lambda_{cd} = \lambda_{qd} - (1 - \lambda_{qd})/N_q \tan \phi^l = 1.05 - (1 - 1.05)/11 \tan(25) = 1.06$$

$$\lambda_{\gamma d} = 1$$

Load inclination factors:

$$\lambda_{qi} = (1 - 0.7H/(V_{\text{drained}} + c^l B^l \cot \phi^l))^3 = (1 - 0.7 \times 70.47/(144.48 + 12.5 \times 2.27 \times \cot(25)))^3 = 0.46$$

$$\lambda_{ci} = (\lambda_{qi} N_q - 1)/(N_q - 1) = 0.40$$

$$\lambda_{\gamma i} = (1 - H/(V_{\text{drained}} + c^l B^l \cot \phi^l))^3 = (1 - 70.47/(144.48 + 12.5 \times 2.27 \times \cot(25)))^3 = 0.28$$

$$q_{u,\text{drained}} = c^l N_c \lambda_{cd} \lambda_{ci} + q^l N_q \lambda_{qd} \lambda_{qi} + 0.5 B^l \gamma^l N_\gamma \lambda_{\gamma d} \lambda_{\gamma i}$$

$$= 12.5 \times 21 \times 1.06 \times 0.40 + 3.3 \times 11 \times 1.05 \times 0.46 + 0.5 \times 9 \times 2.27 \times 8.2 \times 1 \times 0.28 = 152.29$$

$$q_{\text{dbs_drained}} = q_{u,\text{drained}} \Phi_{bc} = 152.29 \times 0.45 = 68.5 \quad q_d = 63.7$$

Thus OK as $q_{\text{dbs_drained}} > q_d$

C12.0 Sixth Ultimate Limit State (long term foundation sliding failure)

The design sliding strength is derived from the sliding resistance on the base and the passive resistance from the clay in front of the embedded part.

$$\text{Sliding resistance: } S_{\text{drained}} = c^l B^l + V_{\text{drained}} \tan \phi^l = 12.5 \times 2.27 + 144.48 \times \tan(25) = 95.75$$

$$\begin{aligned} \text{Passive resistance: } P_{p,\text{drained}} &= 0.5 K_p \gamma^l T_f^2 + 2c^l T_f \sqrt{K_p} \\ &= 0.5 \times 3.5 \times 8.2 \times 0.4^2 + 2 \times 12.5 \times 0.4 \times \sqrt{3.5} = 21.00 \end{aligned}$$

$$\text{Design sliding strength: } S \Phi_{sl} + P_p \Phi_{pp} = 95.75 \times 0.8 + 21.00 \times 0.45 = 86.05$$

$$H = 70.5$$

Thus OK as $S \Phi_{sl} + P_p \Phi_{pp} > H$

ARCHIVED

C13.0 Comments

The above calculations reveal that, for static loading, it is the long term case that is critical. Also for the short term cases the sliding strength derived from passive earth pressure in front of the embedded foundation is significant.

If the horizontal earthquake acceleration is increased much above 0.2g the third ultimate limit state becomes the limiting case as bearing failure is initiated. However, as explained in clauses 4.11.2.4 and C4.11.2.4 of NZS 4402: 1992, controlled sliding and tilting of the foundation during the passage of an earthquake is possible if the resulting post-earthquake permanent displacements are acceptable. The procedures and criteria for this approach are beyond the scope of this document.

Acceptable Solution B1/AS4 Foundations

ARCHIVED

(Revised by Amendment 4)

No specific acceptable solution for foundations has been adopted for complying with the Performances of NZBC B1.

ARCHIVED

Index B1/VM1/VM2/VM3/VM4 & AS1/AS2/AS3/AS4 (Revised by Amendment 4)

All references to Verification Methods and Acceptable Solutions are preceded by **VM** or **AS** respectively.

Amend 11
Aug 2011

Buildings **AS3** 1.9.2, 1.9.4
 building elements **VM4** 2.0.3
 earth buildings **VM1** 8.0, **AS1** 4.0

Amend 8
Dec 2008

masonry buildings **AS1** 2.0, **AS3** 1.1.1
 timber framed buildings **AS1** 3.0, **AS3** 1.1.1

Amend 11
Aug 2011

Chimneys **AS1** 1.2, 8.0, **AS3** 2.1

bracing units **AS3** 1.9, 1.9.3, 1.9.6, Table 2
 brick chimneys **AS3** 1.1, 1.1.3 a) b), 1.2.1 a), 1.6.2 a), 1.7.1,
 1.7.6, 1.8.1, 1.8.5 a), Figures 2, 3, 4, 7, Table 1

cantilever height **AS3** 1.1.2

chimney bases **AS3** 1.1.3 a), 1.6.1, 1.9.4 b)

chimney breasts **AS3** 1.5, Table 1

chimney depth **AS3** 1.1.3

chimney height **AS3** 1.1.2

chimney liners **AS3** 1.1.4

chimney lintels **AS3** Table 1

Amend 8
Dec 2008

chimney materials **AS3** 1.8

chimney stacks **AS3** 1.1.2, 1.6.1

chimney wall thicknesses **AS3** 1.2, 1.2.1

chimney width **AS3** 1.1.3

concrete chimneys **AS3** 1.1.1, 1.1.3 a) c), 1.2.1 b) c),
 1.6.2 a) b), 1.7.1, 1.7.13, 1.8.2,
 1.8.5 b), Figures 4, 5, Table 1

concrete masonry **AS3** 1.8.4

floor brackets **AS3** 1.7.1, 1.7.3, 1.7.4, 1.7.5, 1.8.4, 1.9.4 b) c), Figure 6

foundations **AS3** 1.1.2, 1.1.3 a), 1.3, 1.3.1, 1.3.2,
 1.3.3, 1.7.4, 1.7.5, 1.8.4, Figure 1

 foundation slabs **AS3** 1.1.2, 1.3.2, 1.7.4, 1.7.5

gathers **AS3** 1.6.1, 1.6.2, 1.7.5

packers **AS3** 1.7.2, 1.7.6 c)

precast pumice concrete chimneys **AS3** 1.1.1, 1.1.3 a) c),
 1.2.1 c), 1.6.2 b), 1.7.1, 1.7.13, 1.8.3,
 1.8.3 c), 1.8.5 c), Figures 5, 7, Table 1

 compressive strength **AS3** 1.8.3 c)

 construction of **AS3** 1.8.3

restraint **AS3** 1.7, 1.7.1, 1.7.13, Figures 6, 7

roof brackets **AS3** 1.7.1, 1.7.3, 1.7.4, Figure 6

roof ties **AS3** 1.7.5

structural diaphragms **AS3** 1.9.5

ARCHIVED

Chimneys (continued)

- wall ties **AS3** 1.75, 1.77, 1.78
- closely spaced wall ties **AS3** 1.75, 1.9.4 c)

Concealed works **VM4** A1.2.1 b)

Concrete see Design, concrete

Design

- aluminium **VM1** 7.0
- Amend 17 Nov 2018 | composite steel-concrete **VM1** 5.1.4A
- concrete **VM1** 3.0
- Amend 8 Dec 2008 | concrete masonry **VM1** 4.0, **AS1** 2.0, **AS3** 1.3.3
- drains. see Drains
- Amends 8 and 11 | earth building. **VM1** 8.0, **AS1** 4.0
- foundations see Foundations
- loadings. **VM1** 2.0
- Amend 10 May 2011 | earthquake **VM1** 1.0, 2.0, **AS1** 1.4, **AS3** 1.9, Table 2
- limit state. **VM1** 2.0, 7.1
- Amend 8 Dec 2008 | siteworks. **VM1** 10.0
- Amend 18 Jun 2019 | steel **VM1** 5.0, **AS1** 9.0
- strength reduction factor. **VM4** 2.0.1, 3.5.1, 4.7, Tables 1, 4
- Amend 8 Dec 2008 | structural design actions Standards **VM1** 2.0
- timber **VM1** 6.0, **AS1** 3.0
- Amend 11 Aug 2011 | windows see Windows

Drains **VM1** 11.0, **AS1** 6.0

Ductile steel mesh **VM1** 3.1(d), 14.0

- Amend 14 Nov 2016 | Grade 500E welded steel mesh **VM1** 14.1, **AS1** 2.1.3, 3.1.8

Earth retaining structures **VM4** 2.0.3

Amend 8 Dec 2008

Effluents **VM4** A1.2.1 f)

Amend 8 Dec 2008

Amend 11 Aug 2011

Amend 8 Dec 2008

Foundations **VM1** 9.0, **VM4**

- design parameters
- continuous vibration. **VM4** 1.0.6
- depth **VM4** 2.0.4
- ground stability **VM4** 1.0.4
- long-term loading **VM4** 2.0.6
- short-term loading **VM4** 2.0.6
- serviceability deformations **VM4** 1.0.3, Appendix B

Foundations (continued)

pile foundations	VM4 4.0
belled piles	VM4 4.0.3 b), 5.1.2
bulbed piles	VM4 4.0.3 c)
concrete piles	
cast-in-situ	VM4 3.4.4
precast	VM4 3.4.4, 5.1.1
downdrag	VM4 4.5
nominal width	VM4 4.0.3, 4.2, 4.6.1
notation	VM4 4.1.1, Figure 5, Table 2
pile driving	VM4 5.1.1
pile driving formula	VM4 4.0.1
pile groups	
design pile lateral strength	VM4 4.0.4
design pile vertical strength	VM4 4.0.4
ultimate lateral strength	VM4 4.6.1, Table 3
ultimate vertical strength	VM4 4.4.1
single piles	
base resistance	VM4 4.1.3, Figures 3, 4
column action design	VM4 4.2
design pile vertical strength	VM4 4.0.4
design pile lateral strength	VM4 4.0.4
lateral strength	VM4 4.3
drained cohesionless soil	VM4 4.3.4
free head pile	VM4 4.3.2 a), 4.3.3 a), 4.3.4 a)
restrained head pile	VM4 4.3.2 b), 4.3.3 b), 4.3.4 b)
undrained cohesive soil	VM4 4.3.2
undrained consolidated soil	VM4 4.3.3
shaft resistance	VM4 4.1.4, Figure 5, Table 2
ultimate axial compression	VM4 4.0.1, 4.0.2, 4.0.3
vertical strength	VM4 4.1.2
strength reduction factors	VM4 4.7, Table 4
types	
concrete	VM4 5.1.1, 5.1.2
steel	VM4 5.2.1, 5.2.2
timber	VM4 5.3
shallow foundations	VM4 3.0
concrete slab-on-ground	AS1 2.1, 3.1, 4.1, AS3 1.3
design bearing pressure	VM4 3.2.1, 3.2.4
design bearing strength	VM4 3.2.3
design sliding resistance	VM4 3.4.6
local shear	VM4 3.3.3
moment loading	VM4 3.1.4
notation	VM4 3.3.1, Figures 1, 2
soils	VM4 3.1.2, 3.4.3
strength reduction factors	VM4 3.5, Table 1
surcharge	VM4 3.1.3
ultimate bearing strength	VM4 3.1.1, 3.2.2, 3.3.2, Figure 3
ultimate sliding resistance	VM4 3.4.2
ultimate sliding strength	VM4 3.4.4, 3.4.5
see also Chimneys, foundations	

Amend 11
Aug 2011

ARCHIVED

	Geology	VM4 A1.2.1 a)
	Glazing	AS1 7.0
	Ground	
Amend 11 Aug 2011	good ground	AS1 2.1, 3.1, 4.1, AS3 1.3.2
	Ground conditions	VM4 1.0.2, Appendix A
	Ground water	VM4 1.0.2, Appendices A, B
	conditions	VM4 1.0.2
	seasonal changes	VM4 A1.2.1 e)
	tidal changes	VM4 A1.2.1 e)
	Hearths	AS3 1.4, 2.2, 2.2.1, 2.2.2, 2.2.3
	hearth slabs	AS3 2.2, 2.2.1, 2.2.2, 2.2.3
Amend 11 Aug 2011	Hot dip galvanising	AS3 1.8.6
	Landslip	VM4 A1.2.1 a)
	Loadings	see Design, loadings
Amend 8 Dec 2008	Masonry	see Design, concrete masonry
	Materials	AS3 1.8
	chimneys	see Chimneys, chimney material
Amend 8 Dec 2008	Standards	VM1 1.0
	Piles	see Foundations
Amend 11 Aug 2011	Reinforcing steel	AS1 2.1, 3.1, AS3 1.3.2 b) c), 1.4, 1.6, 1.6.1, 1.6.2, 1.8.5, 2.2.1 a), Table 1
Amend 11 Aug 2011	Seismic resistance of engineering systems	VM1 13.0
	Settlement	VM4 4.0.3, Appendix B
	differential settlement	VM4 B1.0.2
	factors affecting settlement	VM4 B1.0.3
	Site characteristics	VM4 Appendix A
	Site investigations	VM4 3.5.1, 4.7.1, Appendix A
	detailed investigations	VM4 A1.3
	preliminary investigations	VM4 A1.2
	recording information	VM4 A1.4
	Siteworks	see Design, siteworks
	Slope stability	VM4 1.0.4
	Small chimneys	see Chimneys
	Soil properties	VM4 1.0.5, 2.0.6, 2.0.7, Appendix A
	Soil shrinkage and expansion	VM4 3.1.2, 3.4.3, A1.2.1 a)
	Soils	
	adverse moisture conditions	VM4 1.0.2
	Solid fuel burning domestic appliances	AS3 2.0

ARCHIVED

Steel see Design, steel

Steel mesh **VM1** 3.1(d), 14.0
Grade 500E welded steel mesh **VM1** 14.1, **AS1** 2.1.3, 3.1.8

Amend 14
Nov 2016

Stucco **AS1** 5.0

Subsidence **VM4** A1.2.1 a)

Timber see Design, timber

Timber barriers **AS2** 1.0

Windows **VM1** 12.0
glazing **AS1** 7.0

Amend 11
Aug 2011